

Making Everything Easier!™

5th Edition

Linux®

ALL-IN-ONE

FOR
DUMMIES®

A Wiley Brand

8 BOOKS
IN **1**

- Getting Started with Linux
- Linux Desktops
- Networking
- The Internet
- Administration
- Security
- Scripting
- Linux Certification

Emmett Dulaney

Author and instructor at Anderson University



Get More and Do More at Dummies.com®



Start with **FREE** Cheat Sheets

Cheat Sheets include

- Checklists
- Charts
- Common Instructions
- And Other Good Stuff!

To access the Cheat Sheet created specifically for this book, go to
www.dummies.com/cheatsheet/linuxaio

Get Smart at Dummies.com

Dummies.com makes your life easier with 1,000s of answers on everything from removing wallpaper to using the latest version of Windows.

Check out our

- Videos
- Illustrated Articles
- Step-by-Step Instructions

Plus, each month you can win valuable prizes by entering our Dummies.com sweepstakes. *

Want a weekly dose of Dummies? Sign up for Newsletters on

- Digital Photography
- Microsoft Windows & Office
- Personal Finance & Investing
- Health & Wellness
- Computing, iPods & Cell Phones
- eBay
- Internet
- Food, Home & Garden

Find out "HOW" at Dummies.com

*Sweepstakes not currently available in all countries; visit Dummies.com for official rules.

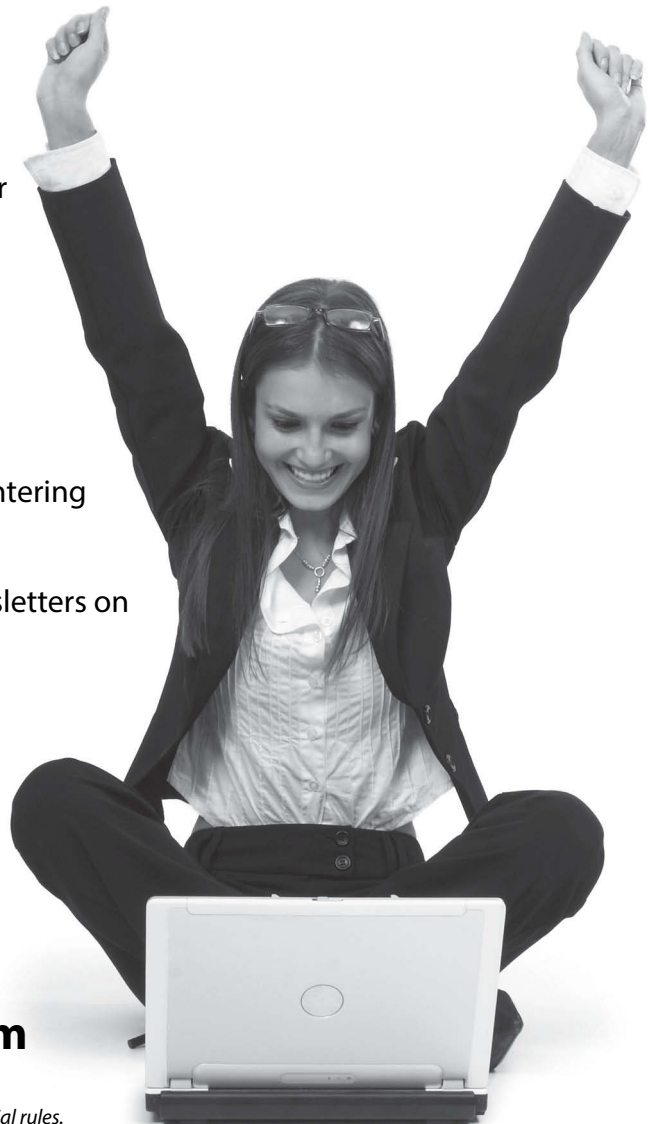

Linux[®]
ALL-IN-ONE

FOR
DUMMIES[®]
A Wiley Brand

5th Edition

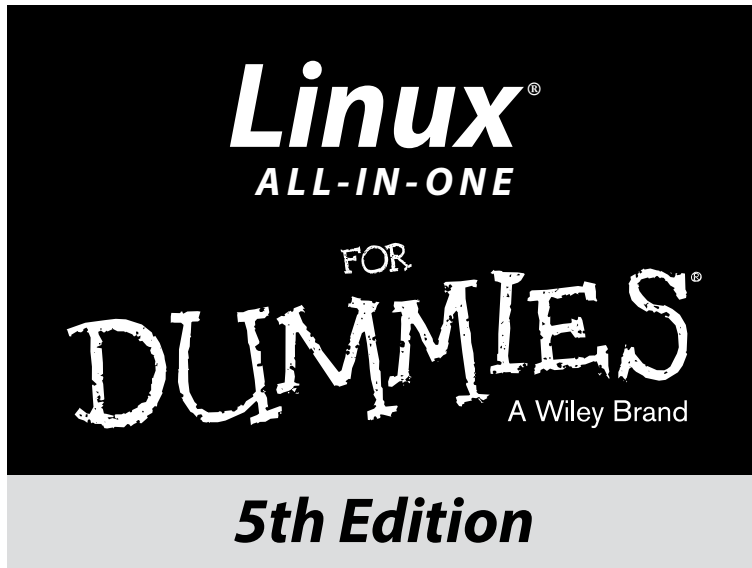

by Emmett Dulaney

FOR
DUMMIES[®]
A Wiley Brand

Linux® All-in-One For Dummies® 5th Edition

Published by: **John Wiley & Sons, Inc.**, 111 River Street, Hoboken, NJ 07030-5774, www.wiley.com

Copyright © 2014 by John Wiley & Sons, Inc., Hoboken, New Jersey

Published simultaneously in Canada

No part of this publication may be reproduced, stored in a retrieval system or transmitted in any form or by any means, electronic, mechanical, photocopying, recording, scanning or otherwise, except as permitted under Sections 107 or 108 of the 1976 United States Copyright Act, without the prior written permission of the Publisher. Requests to the Publisher for permission should be addressed to the Permissions Department, John Wiley & Sons, Inc., 111 River Street, Hoboken, NJ 07030, (201) 748-6011, fax (201) 748-6008, or online at <http://www.wiley.com/go/permissions>.

Trademarks: Wiley, For Dummies, the Dummies Man logo, Dummies.com, Making Everything Easier, and related trade dress are trademarks or registered trademarks of John Wiley & Sons, Inc. and may not be used without written permission. Linux is a registered trademark of Linus Torvalds. All other trademarks are the property of their respective owners. John Wiley & Sons, Inc. is not associated with any product or vendor mentioned in this book.

LIMIT OF LIABILITY/DISCLAIMER OF WARRANTY: THE PUBLISHER AND THE AUTHOR MAKE NO REPRESENTATIONS OR WARRANTIES WITH RESPECT TO THE ACCURACY OR COMPLETENESS OF THE CONTENTS OF THIS WORK AND SPECIFICALLY DISCLAIM ALL WARRANTIES, INCLUDING WITHOUT LIMITATION WARRANTIES OF FITNESS FOR A PARTICULAR PURPOSE. NO WARRANTY MAY BE CREATED OR EXTENDED BY SALES OR PROMOTIONAL MATERIALS. THE ADVICE AND STRATEGIES CONTAINED HEREIN MAY NOT BE SUITABLE FOR EVERY SITUATION. THIS WORK IS SOLD WITH THE UNDERSTANDING THAT THE PUBLISHER IS NOT ENGAGED IN RENDERING LEGAL, ACCOUNTING, OR OTHER PROFESSIONAL SERVICES. IF PROFESSIONAL ASSISTANCE IS REQUIRED, THE SERVICES OF A COMPETENT PROFESSIONAL PERSON SHOULD BE SOUGHT. NEITHER THE PUBLISHER NOR THE AUTHOR SHALL BE LIABLE FOR DAMAGES ARISING HEREFROM. THE FACT THAT AN ORGANIZATION OR WEBSITE IS REFERRED TO IN THIS WORK AS A CITATION AND/OR A POTENTIAL SOURCE OF FURTHER INFORMATION DOES NOT MEAN THAT THE AUTHOR OR THE PUBLISHER ENDORSES THE INFORMATION THE ORGANIZATION OR WEBSITE MAY PROVIDE OR RECOMMENDATIONS IT MAY MAKE. FURTHER, READERS SHOULD BE AWARE THAT INTERNET WEBSITES LISTED IN THIS WORK MAY HAVE CHANGED OR DISAPPEARED BETWEEN WHEN THIS WORK WAS WRITTEN AND WHEN IT IS READ.

For general information on our other products and services, please contact our Customer Care Department within the U.S. at 877-762-2974, outside the U.S. at 317-572-3993, or fax 317-572-4002. For technical support, please visit www.wiley.com/techsupport.

Wiley publishes in a variety of print and electronic formats and by print-on-demand. Some material included with standard print versions of this book may not be included in e-books or in print-on-demand. If this book refers to media such as a CD or DVD that is not included in the version you purchased, you may download this material at <http://booksupport.wiley.com>. For more information about Wiley products, visit www.wiley.com.

Library of Congress Control Number: 2013958402

ISBN 978-1-118-84435-9 (pbk); ISBN 978-1-118-84431-1 (ebk); ISBN 978-1-118-84432-8 (ebk)

Manufactured in the United States of America

10 9 8 7 6 5 4 3 2 1

Contents at a Glance

| | |
|---|------------|
| <i>Introduction</i> | 1 |
| <i>Book I: Getting Started with Linux</i> | 7 |
| Chapter 1: Introducing Linux | 9 |
| Chapter 2: Installing Linux..... | 29 |
| Chapter 3: Troubleshooting and Configuring Linux..... | 37 |
| Chapter 4: Trying Out Linux..... | 57 |
| <i>Book II: Linux Desktops</i> | 67 |
| Chapter 1: GNOME, Unity, Cinnamon, and MATE..... | 69 |
| Chapter 2: The KDE Desktop | 79 |
| Chapter 3: Commanding the Shell | 89 |
| Chapter 4: Navigating the Linux File System..... | 109 |
| Chapter 5: Introducing Linux Applications | 127 |
| Chapter 6: Using Text Editors | 139 |
| <i>Book III: Networking</i> | 151 |
| Chapter 1: Connecting to the Internet | 153 |
| Chapter 2: Setting Up a Local Area Network..... | 167 |
| Chapter 3: Going Wireless | 179 |
| Chapter 4: Managing the Network | 189 |
| <i>Book IV: The Internet</i> | 203 |
| Chapter 1: Browsing the Web..... | 205 |
| Chapter 2: Reading Newsgroups and RSS Feeds..... | 217 |
| Chapter 3: Using FTP | 231 |
| Chapter 4: Hosting Internet Services..... | 241 |
| Chapter 5: Managing Mail and News Servers | 257 |
| Chapter 6: Managing DNS | 279 |
| <i>Book V: Administration</i> | 299 |
| Chapter 1: Introducing Basic System Administration..... | 301 |
| Chapter 2: Managing Users and Groups | 337 |
| Chapter 3: Managing File Systems | 351 |
| Chapter 4: Working with Samba and NFS | 373 |

| | |
|---|------------|
| <i>Book VI: Security</i> | 381 |
| Chapter 1: Introducing Linux Security | 383 |
| Chapter 2: Securing Linux..... | 399 |
| Chapter 3: Computer Security Audits and Vulnerability Testing Types | 429 |
| <i>Book VII: Scripting</i> | 443 |
| Chapter 1: Introductory Shell Scripting | 445 |
| Chapter 2: Advanced Shell Scripting..... | 457 |
| Chapter 3: Programming in Linux..... | 465 |
| <i>Book VIII: Linux Certification</i> | 489 |
| Chapter 1: Studying for the Linux Essentials Certification Exam | 491 |
| Chapter 2: Studying for the CompTIA Linux+ Powered by LPI Certification Exams..... | 501 |
| Chapter 3: Other Linux Certifications | 517 |
| <i>Index</i> | 519 |

Table of Contents

| | |
|--|-----------|
| <i>Introduction</i> | 1 |
| About This Book | 2 |
| Foolish Assumptions | 3 |
| Icons Used in This Book | 4 |
| Beyond the Book | 5 |
| Where to Go from Here | 5 |
| | |
| <i>Book 1: Getting Started with Linux</i> | 7 |
| | |
| Chapter 1: Introducing Linux | 9 |
| What Is Linux? | 9 |
| Linux distributions | 10 |
| Making sense of version numbers | 14 |
| Linux Standard Base (LSB) | 15 |
| Contents of a Linux Distribution | 16 |
| GNU software | 16 |
| GUIs and applications | 19 |
| Networks | 21 |
| Internet servers | 21 |
| Software development | 22 |
| Online documentation | 22 |
| Managing Your PC with Linux | 24 |
| Distribution media | 25 |
| Peripheral devices | 25 |
| File systems and sharing | 26 |
| Network | 26 |
| Getting Started | 27 |
| Step 1: Install | 27 |
| Step 2: Configure | 27 |
| Step 3: Explore | 28 |
| Step 4: Find out more | 28 |
| | |
| Chapter 2: Installing Linux | 29 |
| Following the Installation Steps | 29 |
| Checking Your PC's Hardware | 31 |
| Setting Aside Space for Linux | 33 |
| Trying a Live CD | 34 |

| | |
|---|---------------|
| Installing Linux on a Flash Drive..... | 34 |
| Creating the bootable flash drive | 35 |
| Troubleshooting the workstation..... | 36 |
| Working daily with the new drive..... | 36 |
| Chapter 3: Troubleshooting and Configuring Linux | 37 |
| Using Text Mode Installation | 38 |
| Troubleshooting X..... | 38 |
| Resolving Other Installation Problems..... | 40 |
| Using Knoppix boot commands..... | 40 |
| The fatal signal 11 error..... | 43 |
| Getting around the PC reboot problem | 44 |
| Using Linux kernel boot options..... | 44 |
| Setting Up Printers | 47 |
| Managing DVDs, CD-ROMs, and Flash Drives | 49 |
| Installing Other Software..... | 50 |
| Installing software in Debian and Ubuntu | 50 |
| Installing software in Fedora | 52 |
| Installing software in SUSE | 54 |
| Installing software in Xandros..... | 55 |
| Chapter 4: Trying Out Linux | 57 |
| Starting Linux..... | 57 |
| Playing with the Shell..... | 60 |
| Starting the bash shell..... | 60 |
| Understanding shell commands | 61 |
| Trying a few Linux commands | 62 |
| Shutting Down..... | 64 |
| Book II: Linux Desktops | 67 |
| Chapter 1: GNOME, Unity, Cinnamon, and MATE | 69 |
| Getting to Know the GNOME Desktop | 70 |
| Understanding the GNOME Panels..... | 71 |
| The top panel | 72 |
| The desktop..... | 72 |
| The bottom panel | 73 |
| Looking at Unity..... | 74 |
| Looking at Cinnamon | 75 |
| Looking at MATE..... | 76 |
| Chapter 2: The KDE Desktop | 79 |
| Getting to Know the KDE Desktop..... | 79 |
| Desktop context menus | 80 |
| Icon context menus | 81 |

| | |
|--|----|
| Understanding the KDE Panel..... | 82 |
| The Main Menu button..... | 82 |
| Panel icons..... | 85 |
| Configuring the KDE Bottom Panel | 85 |
| Configuring the KDE Desktop..... | 86 |

Chapter 3: Commanding the Shell 89

| | |
|---|-----|
| Opening Terminal Windows and Virtual Consoles | 89 |
| Using the bash Shell..... | 90 |
| Understanding the syntax of shell commands..... | 90 |
| Combining shell commands | 92 |
| Controlling command input and output | 92 |
| Typing less with automatic command completion | 95 |
| Going wild with asterisks and question marks | 95 |
| Repeating previously typed commands | 97 |
| Discovering and Using Linux Commands..... | 98 |
| Becoming root (superuser) | 101 |
| Managing processes | 102 |
| Working with date and time | 103 |
| Processing files | 104 |
| Writing Shell Scripts..... | 106 |

Chapter 4: Navigating the Linux File System 109

| | |
|---|-----|
| Understanding the Linux File System | 109 |
| Navigating the File System with Linux Commands | 114 |
| Commands for directory navigation | 114 |
| Commands for directory listings and permissions | 116 |
| Commands for changing permissions and ownerships..... | 118 |
| Commands for working with files | 119 |
| Commands for working with directories | 120 |
| Commands for finding files..... | 121 |
| Commands for mounting and unmounting..... | 122 |
| Commands for checking disk-space usage..... | 123 |

Chapter 5: Introducing Linux Applications 127

| | |
|---|-----|
| Taking Stock of Linux Applications..... | 127 |
| Introducing Office Applications and Tools | 128 |
| LibreOffice.org office suite | 128 |
| Calendars | 132 |
| Calculators..... | 132 |
| Checking out Multimedia Applications..... | 133 |
| Using a digital camera | 133 |
| Playing audio CDs | 134 |
| Playing sound files | 135 |
| Burning a CD or DVD | 135 |
| Using Graphics and Imaging Apps..... | 136 |
| The GIMP..... | 136 |
| GNOME Ghostview..... | 138 |

| | |
|--|------------|
| Chapter 6: Using Text Editors | 139 |
| Using GUI Text Editors | 139 |
| Text Editing with ed and vi | 141 |
| Using ed | 141 |
| Using vi | 145 |

Book III: Networking

| | |
|---|------------|
| Chapter 1: Connecting to the Internet | 153 |
| Understanding the Internet | 153 |
| Deciding How to Connect to the Internet | 154 |
| Connecting with DSL | 156 |
| How DSL works | 156 |
| DSL alphabet soup: ADSL, IDSL, SDSL | 157 |
| Typical DSL setup | 158 |
| Connecting with a Cable Modem | 161 |
| How a cable modem works | 161 |
| Typical cable modem setup | 163 |
| Chapter 2: Setting Up a Local Area Network | 167 |
| Understanding TCP/IP | 167 |
| IP addresses | 169 |
| Internet services and port numbers | 170 |
| Setting Up an Ethernet LAN | 172 |
| How Ethernet works | 172 |
| Ethernet cables | 173 |
| Configuring TCP/IP Networking | 175 |
| Connecting Your LAN to the Internet | 177 |
| Chapter 3: Going Wireless | 179 |
| Understanding Wireless Ethernet Networks | 179 |
| Understanding infrastructure and ad hoc modes | 180 |
| Understanding Wired Equivalent Privacy (WEP) | 181 |
| Setting Up Wireless Hardware | 183 |
| Configuring the Wireless Access Point | 184 |
| Configuring Wireless Networking | 185 |
| Chapter 4: Managing the Network | 189 |
| Discovering the TCP/IP Configuration Files | 189 |
| /etc/hosts | 189 |
| /etc/networks | 190 |
| /etc/host.conf | 191 |
| /etc/resolv.conf | 191 |
| /etc/hosts.allow | 192 |

| | |
|--|-----|
| /etc/hosts.deny | 192 |
| /etc/nsswitch.conf | 193 |
| Checking Out TCP/IP Networks | 193 |
| Checking the network interfaces | 193 |
| Checking the IP routing table | 194 |
| Checking connectivity to a host | 195 |
| Checking network status..... | 195 |
| Sniffing network packets..... | 197 |
| Using GUI tools | 198 |
| Configuring Networks at Boot Time..... | 199 |

Book IV: The Internet..... 203

Chapter 1: Browsing the Web205

| | |
|--|-----|
| Discovering the Web | 205 |
| Like a giant spider's web..... | 206 |
| Links and URLs..... | 206 |
| Web servers and web browsers..... | 209 |
| Web Browsing in Linux | 209 |
| Checking out web browsers for Linux | 209 |
| Introducing Firefox's user interface | 210 |
| Changing your home page | 212 |
| Surfing the Internet with Firefox | 215 |

Chapter 2: Reading Newsgroups and RSS Feeds.217

| | |
|--|-----|
| Understanding Newsgroups..... | 218 |
| Newsgroup hierarchy..... | 218 |
| Top-level newsgroup categories..... | 219 |
| Linux-related newsgroups | 221 |
| Reading Newsgroups from Your ISP | 222 |
| Taking stock of newsreaders..... | 222 |
| Reading newsgroups with Thunderbird | 223 |
| Newsgroup subscriptions..... | 225 |
| Posting news..... | 225 |
| Using KNode | 226 |
| Reading and Searching Newsgroups at Websites | 227 |
| Reading RSS Feeds..... | 228 |
| Examining an RSS Feed..... | 229 |
| Reading RSS Feeds | 229 |

Chapter 3: Using FTP231

| | |
|---|-----|
| Using Graphical FTP Clients..... | 231 |
| Using gFTP | 232 |
| Introducing FileZilla..... | 234 |
| Using a web browser as an FTP client..... | 234 |
| Using the Command-Line FTP Client..... | 236 |

| | |
|--|------------|
| Chapter 4: Hosting Internet Services | 241 |
| Understanding Internet Services | 241 |
| TCP/IP and sockets | 242 |
| Internet services and port numbers | 245 |
| Using the Internet Super Server | 247 |
| Using inetd | 247 |
| Using xinetd | 248 |
| Running Standalone Servers | 250 |
| Starting and stopping servers manually | 250 |
| Starting servers automatically at boot time | 251 |
| | |
| Chapter 5: Managing Mail and News Servers | 257 |
| Installing the Mail Server | 257 |
| Using sendmail | 257 |
| A mail-delivery test | 258 |
| The mail-delivery mechanism | 259 |
| The sendmail configuration file | 259 |
| Syntax of the sendmail.cf file | 264 |
| Other sendmail files | 266 |
| The .forward file | 267 |
| The sendmail alias file | 268 |
| Installing the INN Server | 268 |
| Configuring and Starting the INN Server | 269 |
| InterNetNews components | 270 |
| The incoming.conf file | 274 |
| The readers.conf file | 274 |
| InterNetNews startup | 274 |
| Setting Up Local Newsgroups | 275 |
| Defining a newsgroup hierarchy | 275 |
| Updating configuration files | 276 |
| Adding the newsgroups | 276 |
| Testing your newsgroups | 277 |
| | |
| Chapter 6: Managing DNS | 279 |
| Understanding Domain Name System (DNS) | 279 |
| What is DNS? | 279 |
| Discovering hierarchical domain names | 281 |
| Exploring Berkeley Internet Name Domain (BIND) | 282 |
| Configuring DNS | 285 |
| Configuring the resolver | 285 |
| Configuring a caching name server | 286 |
| Configuring a primary name server | 296 |

Book V: Administration 299

Chapter 1: Introducing Basic System Administration 301

- Taking Stock of System Administration Tasks..... 301
- Introducing Some GUI Sysadmin Tools 303
- How to Become root 305
 - Using the su - command..... 306
 - Becoming root for the GUI utilities..... 307
 - Recovering from a forgotten root password 307
- Understanding How Linux Boots 308
 - Understanding the init process..... 308
 - Examining the /etc/inittab file 310
 - Trying a new run level with the init command 311
 - Understanding the Linux startup scripts..... 312
 - Manually starting and stopping servers 313
 - Automatically starting servers at system startup 313
- Taking Stock of Linux System Configuration Files 314
- Monitoring System Performance 317
 - Using the top utility 318
 - Using the uptime command..... 319
 - Using the vmstat utility..... 320
 - Checking disk performance and disk usage 321
- Viewing System Information
 - with the /proc File System 322
- Understanding Linux Devices 325
 - Device files 326
 - Persistent device naming with udev 327
- Managing Loadable Driver Modules 328
 - Loading and unloading modules..... 328
 - Using the /etc/modprobe.conf file 329
- Scheduling Jobs in Linux 330
 - Scheduling one-time jobs..... 331
 - Scheduling recurring jobs..... 333

Chapter 2: Managing Users and Groups 337

- Adding User Accounts 337
 - Managing user accounts by using a GUI user manager 338
 - Managing user accounts by using commands 342
- Understanding the /etc/passwd File 343
- Managing Groups..... 344
- Other User and Group Administration Values..... 345
- Exploring the User Environment 347
- Changing User and Group Ownership of Files 350

| | |
|---|------------|
| Chapter 3: Managing File Systems | 351 |
| Exploring the Linux File System | 351 |
| Understanding the file-system hierarchy | 352 |
| Mounting a device on the file system..... | 355 |
| Examining the /etc/fstab file..... | 357 |
| Sharing Files with NFS..... | 358 |
| Exporting a file system with NFS..... | 360 |
| Mounting an NFS file system | 360 |
| Backing Up and Restoring Files | 361 |
| Selecting a backup strategy and media..... | 361 |
| Commercial backup utilities for Linux..... | 362 |
| Using the tape archiver — tar | 363 |
| Accessing a DOS or Windows File System..... | 368 |
| Mounting a DOS or Windows disk partition | 368 |
| Mounting those ancient DOS floppy disks..... | 369 |
| Mounting an NTFS partition | 370 |
| | |
| Chapter 4: Working with Samba and NFS | 373 |
| Sharing Files with NFS..... | 373 |
| Exporting a file system with NFS..... | 374 |
| Mounting an NFS file system | 376 |
| Setting Up a Windows Server Using Samba..... | 377 |
| Installing Samba | 378 |
| Configuring Samba..... | 379 |
| Trying out Samba..... | 380 |
| | |
| Book VI: Security | 381 |
| | |
| Chapter 1: Introducing Linux Security | 383 |
| Why Worry about Security? | 383 |
| Establishing a Security Framework..... | 384 |
| Determining business requirements for security..... | 385 |
| Performing risk analysis | 386 |
| Establishing a security policy | 387 |
| Implementing security solutions (mitigation) | 388 |
| Managing security..... | 389 |
| Securing Linux..... | 389 |
| Understanding the host-security issues | 390 |
| Understanding network-security issues | 390 |
| Delving into Computer Security Terminology and Tools..... | 391 |
| Keeping Up with Security News and Updates..... | 397 |
| | |
| Chapter 2: Securing Linux | 399 |
| Securing Passwords | 399 |
| Shadow passwords..... | 400 |
| Pluggable authentication modules (PAMs)..... | 401 |

- Protecting Files and Directories 402
 - Viewing ownerships and permissions..... 402
 - Changing file ownerships..... 402
 - Changing file permissions..... 403
 - Setting default permission..... 403
 - Checking for set user ID permission 405
- Encrypting and Signing Files with GnuPG 406
 - Understanding public key encryption..... 406
 - Understanding digital signatures..... 407
 - Using GPG 408
- Monitoring System Security 412
- Securing Internet Services..... 413
 - Turning off standalone services..... 413
 - Configuring the Internet super server..... 414
 - Configuring TCP wrapper security 414
- Using Secure Shell (SSH) for Remote Logins..... 415
- Setting Up Simple Firewalls 418
 - Using NAT 421
 - Enabling packet filtering on your Linux system..... 421
- Security Files to Be Aware Of..... 426

Chapter 3: Computer Security Audits and Vulnerability Testing Types 429

- Understanding Security Audits..... 429
 - Nontechnical aspects of security audits..... 430
 - Technical aspects of security audits..... 431
- Implementing a Security Test Methodology 431
 - Some common computer vulnerabilities..... 432
 - Host-security review..... 434
 - Network-security review 438
- Vulnerability Testing Types 440
- Exploring Security Testing Tools 440
 - nmap..... 441

***Book VII: Scripting* 443**

Chapter 1: Introductory Shell Scripting 445

- Trying Out Simple Shell Scripts 445
- Exploring the Basics of Shell Scripting 447
 - Storing stuff 447
 - Calling shell functions 448
 - Controlling the flow 449
 - Exploring bash’s built-in commands 451

| | |
|--|----------------|
| Chapter 2: Advanced Shell Scripting | 457 |
| Trying Out sed | 457 |
| Working with awk and sed | 459 |
| Step 1: Pull out the ISBN..... | 460 |
| Step 2: Calculate the 13th digit..... | 461 |
| Step 3: Add the 13th digit to the other 12..... | 462 |
| Step 4: Finish the process | 462 |
| Final Notes on Shell Scripting | 463 |
| Chapter 3: Programming in Linux | 465 |
| An Overview of Programming..... | 465 |
| Exploring the Software-Development Tools in Linux..... | 467 |
| GNU C and C++ compilers..... | 468 |
| The GNU make utility | 472 |
| The GNU debugger..... | 478 |
| Understanding the Implications of GNU Licenses..... | 484 |
| The GNU General Public License | 485 |
| The GNU Library General Public License | 486 |
| Book VIII: Linux Certification | 489 |
| Chapter 1: Studying for the Linux Essentials Certification Exam .. | 491 |
| Overview of Linux Essentials | 491 |
| The Linux Community and a Career in Open Source..... | 492 |
| Using the Command Line to Get Help | 493 |
| The Power of the Command Line | 495 |
| The Linux Operating System | 496 |
| Security and File Permissions | 498 |
| Chapter 2: Studying for the CompTIA Linux+ Powered by LPI Certification Exams | 501 |
| Overview of the CompTIA Linux+ Exams | 501 |
| System Architecture..... | 502 |
| Linux Installation and Package Management..... | 503 |
| GNU and Unix Commands | 505 |
| Devices, Linux File systems, Filesystem Hierarchy Standard..... | 507 |
| Shells, Scripting, and Data Management | 509 |
| User Interfaces and Desktops | 510 |
| Administrative Tasks | 511 |
| Essential System Services | 512 |
| Networking Fundamentals..... | 514 |
| Security..... | 515 |

| | |
|--|----------------|
| Chapter 3: Other Linux Certifications | 517 |
| Vendor-Neutral Certifications | 517 |
| Vendor-Specific Certifications | 518 |
| <i>Index</i> | 519 |

Introduction

Linux is truly amazing when you consider how it originated and how it continues to evolve. From its modest beginning as the hobby of one person — Linus Torvalds of Finland — Linux has grown into a full-fledged operating system with features that rival those of any commercial Unix operating system. To top it off, Linux — with all of its source code — is available free to anyone. All you have to do is download it from an Internet site or get it on CDs or a DVD for a nominal fee from one of many Linux CD vendors.

Linux certainly is an exception to the rule that “you get what you pay for.” Even though Linux is free, it’s no slouch when it comes to performance, features, and reliability. The robustness of Linux has to do with the way it is developed and updated. Developers around the world collaborate to add features. Incremental versions are continually downloaded by users and tested in a variety of system configurations. Linux revisions go through much more rigorous beta testing than any commercial software does.

Since the release of Linux kernel 1.0 on March 14, 1994, the number of Linux users around the world has grown exponentially. Many Linux distributions — combinations of the operating system with applications and installation tools — have been developed to simplify installation and use. Some Linux distributions are commercially sold and supported, while many continue to be freely available.

Linux, unlike many freely available software programs, comes with extensive online information on topics such as installing and configuring the operating system for a wide variety of PCs and peripherals. A small group of hard-core Linux users are expert enough to productively use Linux with the online documentation alone. A much larger number of users, however, move to Linux with some specific purpose in mind (such as setting up a web server or learning Linux). Also, a large number of Linux users use their systems at home. For these new users, the online documentation is not easy to use and typically does not cover the specific uses of Linux that each user may have in mind.

If you’re beginning to use Linux, what you need is a practical guide that not only gets you going with Linux installation and setup, but also shows you how to use Linux for a specific task. You may also want to try out different Linux distributions before settling on one.

About This Book

Linux All-in-One For Dummies gives you eight quick-reference guides in a single book. Taken together, these eight minibooks provide detailed information on installing, configuring, and using Linux, as well as pointers for passing the vendor-neutral certification exams available from the Linux Professional Institute (LPI) to authenticate your skills.

What you'll like most about this book is that you don't have to sequentially read the whole thing chapter by chapter — or even read through each section in a chapter. You can pretty much turn to the topic you want and quickly get the answer to your pressing questions about Linux, whether they're about using the LibreOffice.org word processor, setting up the Apache web server, or a wide range of topics.

Here are some of the things you can do with this book:

- ◆ Install and configure Linux — Debian, Fedora, openSUSE, Ubuntu, or Xandros — using the information given in this book.
- ◆ Connect the Linux PC to the Internet through a DSL or cable modem.
- ◆ Add a wireless Ethernet to your existing network.
- ◆ Get tips, techniques, and shortcuts for specific uses of Linux, such as
 - Setting up and using Internet services
 - Setting up a Windows server using Samba
 - Using Linux commands
 - Using shell programming
 - Using the LibreOffice.org office suite and other applications that come with Linux
- ◆ Understand the basics of system and network security.
- ◆ Perform system administration tasks.

I use a simple notational style in this book. All listings, filenames, function names, variable names, and keywords are typeset in a `monospace` font for ease of reading. I *italicize* the first occurrences of new terms and concepts and then provide a definition right there. I show typed commands in **boldface**. The output of commands and any listing of files are shown in a `monospace` font.

The icons to the certification objectives are important after you've become comfortable enough with the operating system to consider taking the certification exams. They will draw your attention to the key concepts and topics tested upon in the LX0-101 and LX0-102 exams (both of which you must pass to become certified by the Linux Professional Institute).

Each minibook zeros in on a specific task area — such as using the Internet or running Internet servers — and then provides hands-on instructions on how to perform a series of related tasks. You can jump right to a section and read about a specific task. You don't have to read anything but the few paragraphs or the list of steps that relate to your question. Use the Table of Contents or the Index to locate the pages relevant to your question.

You can safely ignore text next to the Technical Stuff icons, as well as text in sidebars. However, if you're the kind of person who likes to know some of the hidden details of how Linux works, then by all means, dig into the Technical Stuff icons and the sidebars.

If you are a novice to Linux, overlook the certification objective icons as you read. Only after you become comfortable with the operating system, and are considering authenticating your skills by taking the LPI exams, should you revisit the book and look for these icons.

Foolish Assumptions

I assume that you're familiar with a PC — you know how to turn it on and off and you've dabbled with Windows. (Considering that most new PCs come preloaded with Windows, this assumption is safe, right?) And I assume that you know how to use some Windows applications, such as Microsoft Office.

When installing Linux on your PC, you may want to retain your Windows installations. I assume that you don't mind shrinking the Windows partition to make room for Linux. For this procedure, you can invest in a good disk-partitioning tool or use one of the partitioning tools included with most Linux distributions.

I also assume that you're willing to accept the risk that when you try to install Linux, some things may not quite work. Problems can happen if you have some uncommon types of hardware. If you're afraid of ruining your system, try finding a slightly older, spare Pentium PC that you can sacrifice and then install Linux on that PC.

Sidebars

Sometimes I use sidebars to highlight interesting, but not critical, information. Sidebars explain concepts you may not have encountered

before or give a little insight into a related topic. If you're in a hurry, you can safely skip the sidebars.

Linux All-in-One Desk Reference For Dummies has eight minibooks, each of which focuses on a small set of related topics. If you're looking for information on a specific topic, check the minibook names on the spine or consult the Table of Contents.

Icons Used in This Book

Following the time-honored tradition of the *All-in-One For Dummies* series, I use icons to help you quickly pinpoint useful information. The icons include the following:



The Distribution Specific icon points out information that applies to specific Linux distributions that this book covers: Debian, Fedora, Knoppix, SUSE, Ubuntu, and Xandros.



The Remember icon marks a general, interesting fact — something that you want to know and remember as you work with Linux. You might even find interesting trivia worth bringing up at an evening dinner party.



When you see the Tip icon, you're about to read about something you can do to make your job easier. Long after you've finished with the first reading of this book, you can skim the book, looking for only the tips.



I use the Warning icon to highlight potential pitfalls. With this icon, I'm telling you: "Watch out! Whatever is being discussed could hurt your system." They say that those who are forewarned are forearmed, so I hope these entities will save you some frustration.



The Technical Stuff icon marks technical information that could be of interest to an advanced user (or those aspiring to be advanced users).



When you see this icon, the material or command being covered here is on the LPI LX0-101 exam.



When you see this icon, the material or command being covered here is on the LPI LX0-102 exam.

Beyond the Book

This book does not stop with the physical copy you hold in your hands. In addition to the content that is here, you'll find a number of things worth looking at on the Dummies website. Among them are links to discussions of other distributions and related technologies. You can access them at www.dummies.com/extras/linuxaio

Occasionally, we have updates to our technology books. If this book does have any technical updates, they'll be posted at www.dummies.com/go/extras/linuxaio.

Where to Go from Here

It's time to get started on your Linux adventure. Turn to any chapter and let the fun begin. Use the Table of Contents and the Index to figure out where you want to go. Before you know it, you'll become an expert at Linux!

I hope you enjoy consulting this book as much as I enjoyed writing it!

Book I

Getting Started with Linux

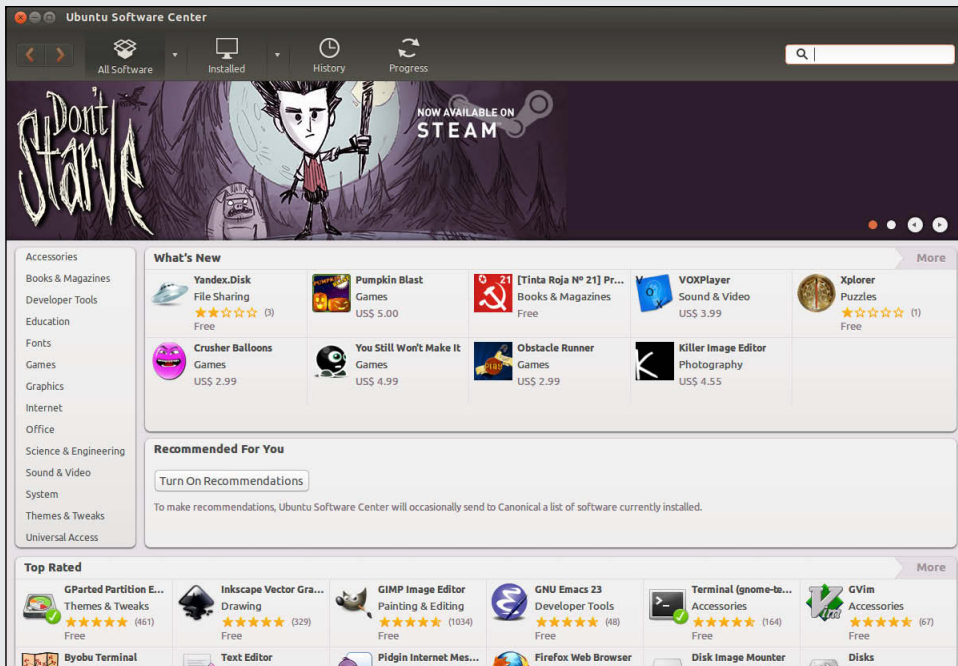

Visit www.dummies.com for great Dummies content online.

Contents at a Glance

| | |
|---|-----------|
| Chapter 1: Introducing Linux | 9 |
| What Is Linux? | 9 |
| Contents of a Linux Distribution | 16 |
| Managing Your PC with Linux | 24 |
| Getting Started | 27 |
| Chapter 2: Installing Linux | 29 |
| Following the Installation Steps | 29 |
| Checking Your PC's Hardware | 31 |
| Setting Aside Space for Linux | 33 |
| Trying a Live CD | 34 |
| Installing Linux on a Flash Drive | 34 |
| Chapter 3: Troubleshooting and Configuring Linux | 37 |
| Using Text Mode Installation | 38 |
| Troubleshooting X | 38 |
| Resolving Other Installation Problems | 40 |
| Setting Up Printers | 47 |
| Managing DVDs, CD-ROMs, and Flash Drives | 49 |
| Installing Other Software | 50 |
| Chapter 4: Trying Out Linux | 57 |
| Starting Linux | 57 |
| Playing with the Shell | 60 |
| Shutting Down | 64 |

Chapter 1: Introducing Linux

In This Chapter

- ✓ Explaining what Linux is
- ✓ Going over what Linux distributions typically include
- ✓ Discovering what Linux helps you manage
- ✓ Getting started with Linux

By virtue of your holding this book in your hands, it's a safe bet that you've heard something about Linux. If you're wondering just exactly what Linux is, whether it's worth serious consideration, and what it can help you do, this chapter is for you. Here I provide a broad picture of Linux and tell you how you can start using it right away.



Although Linux can run on many hardware platforms, this book focuses on Linux for Intel 80x86 and Pentium processors (basically any PC that can run any flavor of Windows).

What Is Linux?

A PC can be thought of as a combination of *hardware* — things you can touch, such as the system box, monitor, keyboard, and mouse. The system box contains the most important hardware of all — the *central processing unit* (CPU), the microchip that runs the *software* (any program that tells the computer how to do your bidding), which you can't actually touch. In a typical Pentium-based PC, the Pentium microprocessor is the CPU. Other important hardware in the system box includes the memory (RAM chips) and the hard drive.

The *operating system* is the program that has to interact with all the hardware and get it to play nice. The operating system software manages all that hardware and runs other software at your command. You, the user, provide those commands by choosing menus, clicking icons, or typing cryptic text. Linux is an operating system — as are Unix, Mac OS, Windows 7 or 8, Windows Vista, and even older Windows versions. The Linux operating system is modeled after Unix; in its most basic, no-frills form, the Linux operating system also goes by *Linux kernel*.

The operating system is what gives a computer — any computer — its personality. For example, you can run Windows on a PC — and on that same PC, you can also install and run Linux. Then, depending on which operating system is installed and running at any particular time, the same PC can operate as a Windows system or as a Linux system.



Does Linux really run on any computer?

Linux runs on many types of computer systems — and there are so many distributions that it does seem able to run on nearly any type of computer.

Linus Torvalds and other programmers developed Linux for the Intel 80x86 (and compatible) line of processors. This book covers Linux for Intel 80x86 and Pentium processors. (These are known as the *IA32 architecture* processors, or *i386*, because they support the instruction set of the 80386 processor.)

Nowadays Linux is also available for systems based on other processors — such as

- ✓ AMD's 64-bit AMD64 processors
- ✓ The Motorola 68000 family

- ✓ Alpha AXP's
- ✓ Sun SPARC's and UltraSPARC's
- ✓ Hewlett-Packard's HP PA-RISC
- ✓ The PowerPC and PowerPC64 processors
- ✓ The MIPS R4x00 and R5x00

IBM has released its own version of Linux for its S/390 and zSeries mainframes. And a number of popular Linux distributions, including Ubuntu and Fedora, can even be run on Sony's Playstation 3 video game system.

The primary job of an operating system is to load software (computer programs) from the hard drive (or other permanent storage) into the memory and get the CPU to run those programs. Everything you do with your computer is possible because of the operating system, so if the operating system somehow messes up, the entire system freezes. You may know how infuriating it can be when your favorite operating system — maybe even the one that came with your PC — suddenly calls it quits just as you were about to click the Send button after composing that long e-mail to your friend. You try a number of things frantically, but nothing happens. Then it's time for the Reset button (or pulling the cord from the back of the machine if your computer's builders weren't wise enough to include a Reset). Luckily, that sort of thing almost never happens with Linux — it has a reputation for being a very reliable operating system.



In technical mumbo jumbo, Linux is a *multiuser, multitasking operating system*. Those terms just mean that Linux enables multiple users to log in, and each of those users can run more than one program at the same time. Nearly all operating systems are multiuser and multitasking these days, but when Linux first started in 1993, *multiuser* and *multitasking* were big selling points.

Linux distributions

A *Linux distribution* consists of the Linux *kernel* (the operating system) and a collection of applications, together with an easy-to-use installation program.



Most people just say *Linux* to refer to a specific Linux distribution.

You will find many Linux distributions, and each includes the standard Linux operating system and the following major packages:

- ◆ **The X Window System:** It's the graphical user interface.
- ◆ **One or more graphical desktops:** Among the most popular are GNOME and KDE.
- ◆ **A selection of applications:** Linux programs come in the form of ready-to-run software, but the *source code* (the commands we humans use to tell the computer what to do) is included (or available), as is its documentation.

Current Linux distributions include a huge selection of software — so much that some distributions usually require one or more DVD-ROMs.



The development and maintenance of the Linux kernel, the software packages in a Linux distribution, and the Linux distributions themselves are organized as *open source* projects. In a nutshell, *open source* means access to the source code and the right to freely redistribute the software without any restrictions. There's a lot more to the definition than this succinct note. To find out the details of what open source means and the acceptable open source licenses, you can visit the Open Source Initiative website at www.opensource.org.

Table 1-1 lists a few major Linux distributions along with a brief description of each. Note, however, that there are many more Linux distributions than the ones shown in Table 1-1. To find out more about Linux distributions, visit DistroWatch.com at <http://distrowatch.com>. At that website, you can read up on specific distributions as well as find links for downloading or ordering DVDs for specific distributions.

Table 1-1 Major Linux Distributions

| <i>Distribution</i> | <i>Description</i> |
|---------------------|--|
| Debian GNU/Linux | This noncommercial distribution started in 1993 and continues to be a popular distribution, with many volunteer developers around the world contributing to the project. Debian is a huge distribution that takes some time to install. After you have installed the base Debian system, you can install and upgrade Debian packages easily with a package installer called <code>apt-get</code> (where <i>apt</i> stands for the Advanced Packaging Tool.) Debian is available free of charge from www.debian.org . Debian is the basis for several other recent distributions including Knoppix, MEPIS, Ubuntu, and Xandros. |

(continued)

Table 1-1 (continued)

| <i>Distribution</i> | <i>Description</i> |
|---------------------|--|
| Fedora | This distribution, once known as Fedora Core, is the successor to Red Hat Linux, which is the Linux distribution from Red Hat. Fedora Core 1, released in November 2003, was the successor to Red Hat Linux 9. The alpha release of Fedora 13 was in 2010. Fedora is freely available and uses the Red Hat Package Manager (RPM) format for its software packages. You can download Fedora Core from http://fedoraproject.org . The latest Fedora download can be found at http://fedoraproject.org/en/get-fedora . |
| Gentoo Linux | This is a noncommercial, <i>source-based</i> (all software is provided in source-code form) distribution that first appeared in 2002. The installer provides some binary packages to get the Linux going, but the idea is to compile all source packages on the user's computer. The requirement to install so much makes it time-consuming to build a full-fledged Gentoo system with the latest graphical desktops, multimedia, and development tools because all the packages have to be downloaded and compiled. Gentoo Linux is freely available from www.gentoo.org . |
| Knoppix | This Live distribution is based on Debian and named after its developer, Klaus Knopper of Germany. Knoppix can be used as a recovery tool (to fix problems with an already installed Linux system) because you can run Knoppix directly from a CD without having to first install it on the hard drive. (Although other distributions have this capability, Knoppix is ideally suited for the task.) The Knoppix CD stores software in compressed format, and Knoppix decompresses the programs on-the-fly. With this approach, Knoppix can pack up to 2GB of software on a CD. Knoppix uses the Debian package management. For information on downloading Knoppix free of charge, visit the Knoppix website at www.knopper.net/knoppix/index-en.html . |
| Linspire | This commercial distribution was first released in 2002 under the name LindowsOS. Linspire uses the Debian package format and offers software downloads for a fee through what it calls the Click-N-Run web-based interface. Though you can still find it and download it from some locations, Linspire was acquired by Xandros in 2008 and has since been discontinued as a Linux distribution. |
| Mandriva Linux One | This popular distribution began life as a 1998 release of Red Hat Linux with an easy-to-use installer and with KDE as the default desktop. Until recently, this distribution was called Mandrakelinux. Mandriva Linux One uses the Red Hat Package Manager (RPM) format for its software packages. You can download the latest version at www.mandriva.com . Click the Download link for more information. |

| <i>Distribution</i> | <i>Description</i> |
|---------------------|--|
| MEPIS Linux | This Debian-based Live distribution was first released in July 2003. It includes a graphical installer that can be launched from the Live distribution to install MEPIS on the hard drive. MEPIS has good hardware detection and comes with Java and multimedia software, which makes it popular. MEPIS uses the Debian package format. You can download from www.mepis.org . |
| Slackware Linux | This distribution is one of the oldest, having been first released in 1992. Slackware uses compressed <code>tar</code> files for its packages and provides a text-based installer with limited automatic detection of hardware. You do all software configurations by editing text files. Slackware is freely available from www.slackware.com . |
| SUSE Linux | This commercial distribution switched to a community development project called openSUSE in August 2005. SUSE Linux Open Source Software (OSS) is now freely available, and the retail SUSE Linux is based on the open source version. SUSE comes with the YaST installation and configuration tool, which is one of the best administration tools available. SUSE Linux uses RPM packages. The openSUSE project provides the ISO image files from various mirror sites. Visit www.opensuse.org for more information. |
| Ubuntu Linux | This Debian-based, noncommercial Linux distribution has become very popular since its initial release in 2004. Ubuntu is available as both an install distribution and a Live distribution. Because it's Debian based, you can install the basic desktop system from the install media and then use the <code>apt-get</code> tool to install other packages as well as keep the system up to date. You can download Ubuntu free of charge from www.ubuntu.com/download . |
| Xandros Desktop OS | This distribution is the successor to Corel Linux and is based on Debian. Xandros is aimed at first-time Linux users, with an installer that can repartition the hard drive. The versatile Xandros File Manager is a key selling point of this distribution. However, Xandros includes some proprietary components that prevent redistribution. A trial version of both Xandros Desktop and Server can be downloaded for evaluation. In 2008, Xandros acquired Linspire, developer of the Linspire and Freespire Linux desktop operating systems. Visit www.xandros.com.ar for more information about Xandros. |

As you can see from the brief descriptions in Table 1-1, some Linux distributions, such as Knoppix and MEPIS, are in the form of Live CDs or DVDs. A *Live* version includes a Linux kernel that you can boot and run directly from the CD or DVD without having to first install it on your hard drive. Such Live distributions can be handy if you want to try out a distribution before you decide whether to install it.

Many Linux distributions are commercial products that you can buy online or in computer stores and bookstores. If you have heard about open source and the *GNU* (which stands for GNU's Not Unix) license, you may think that no one can sell Linux for profit. Luckily for companies that sell Linux distributions, the GNU license — also called the GNU General Public License (GPL) — does allow commercial, for-profit distribution (but requires that the software be distributed in source-code form) and stipulates that anyone may copy and distribute the software in source-code form to anyone else. Several Linux distributions are available free of charge under the GPL, which means that you can download as many copies of the OS as you like.

Making sense of version numbers



The Linux kernel — and each Linux distribution — has its own version number. Additional software programs (such as GNOME and KDE) that come with the Linux distribution have their own version numbers as well. The version numbers for the Linux kernel and the Linux distributions are unrelated, but each has particular significance.

Linux kernel version numbers

After Linux kernel version 1.0 was released on March 14, 1994, the loosely knit Linux development community adopted a version-numbering scheme. Version numbers such as 1.x.y and 2.x.y, where *x* is an even number, are considered the stable versions. The last number, *y*, is the patch level, which is incremented as problems are fixed. For example, 2.6.14 is a typical, stable version of the Linux kernel. Notice that these version numbers are in the form of three integers separated by periods — *major.minor.patch* — where *major* and *minor* are numbers denoting the major and minor version numbers, and *patch* is another number representing the patch level.

Version numbers of the form 2.x.y with an odd *x* number are beta releases for developers only; they may be unstable, so you shouldn't adopt such versions for day-to-day use. For example, if you were to find version 2.7.5 of the Linux kernel, the 7 in the minor version number tells you it's a beta release. Developers add new features to these odd-numbered versions of Linux.

You can find out about the latest version of the Linux kernel online at www.kernel.org.

Distribution-specific version numbers

Each Linux distribution has a version number as well. These version numbers usually follow the format *x.y*, where *x* is the *major* version, and *y* is the *minor* version.

Unlike with the Linux kernel's version numbers, no special meaning is associated with odd- and even-numbered minor versions. Each version of a Linux distribution includes specific versions of the Linux kernel and other major components, such as GNOME, KDE, and various applications.

The developers of active Linux distributions usually release new versions of their distribution on a regular basis — about every six to nine months. For example, Ubuntu 13.43 was released in April 2013; 13.10 was released in October 2013. Typically, each new major version of a Linux distribution provides significant new features.



Debian always has at least three releases at any time — *stable*, *unstable*, and *testing*.

- ◆ **Stable:** Most users prefer this type of release because it's the latest officially released distribution.
- ◆ **Unstable:** The developers are working on this release.
- ◆ **Testing:** The release contains packages that have gone through some testing but aren't ready for inclusion in the stable release yet.

Linux Standard Base (LSB)

Linux has become important enough that there's a standard for Linux called the Linux Standard Base (or LSB, for short). *LSB* is a set of binary standards that should help reduce variations among the Linux distributions and promote portability of applications. The idea behind LSB is to provide an application binary interface (ABI) so that software applications can run on any Linux (or other Unix) systems that conform to the LSB standard. The LSB specification references POSIX (Portable Operating System Interface) standards as well as many other standards, such as the C and C++ programming language standards, the X Window System version 11 release 6 (X11R6), and the Filesystem Hierarchy Standard (FHS). LSB version 1.2 (commonly referred to as *LSB 1.2*) was released on June 28, 2002. LSB 2.0 was released on August 30, 2004, and LSB 4.0, on November 11, 2008.

The LSB specification is organized into two parts — a common specification that remains the same across all types of processors and a set of hardware-specific specifications, one for each type of processor architecture. For example, LSB 1.2 has architecture-specific specifications for Intel 32-bit (IA32) and PowerPC 32-bit (PPC32) processors. LSB 1.3 adds a specification for the Intel 64-bit (IA64) architecture and IBM zSeries 31-bit (S/390) and 64-bit (S390X)

processors, in addition to the ones for IA32 and PPC32. LSB 2.0 added specification for the AMD 64-bit (AMD64 or X86_64) processors. The current LSB specification — LSB 4.0 — supports seven processor architectures: IA32, IA64, PPC32, PPC64 (64-bit PowerPC), S390, S390X, and X86_64.

An LSB certification program exists. Several Linux distributions are certified to be LSB-compliant, IA32 runtime environments. To discover more about LSB, visit <http://www.linuxfoundation.org/collaborate/workgroups/lsb>. The latest list of LSB-certified systems is available at www.linuxfoundation.org.

Contents of a Linux Distribution

A Linux distribution comes with the Linux kernel and a lot more software. These software packages include everything from graphical desktops to Internet servers to programming tools for creating new software. In this section, I briefly describe some major software packages that are bundled with typical Linux distributions. Without this bundled software, Linux wouldn't be as popular as it is today.

GNU software

At the heart of a Linux distribution is a collection of software that came from the GNU Project. You get to know these GNU utilities only if you use your Linux system through a *text terminal* — a basic command-line interface that doesn't use onscreen visuals; instead, it shows you a prompt at which you type your commands. (Or you could use a graphical window that mimics a text terminal and still have use of GNU utilities.) The GNU software is one of the basic parts of any Linux distribution.

What is the GNU Project?

GNU is a recursive acronym that stands for GNU's Not Unix. The GNU Project was launched in 1984 by Richard Stallman to develop a complete Unix-like operating system. The GNU Project developed nearly everything needed for a complete operating system except for the operating system kernel.

All GNU software was distributed under the GNU General Public License (GPL). GPL essentially requires that the software is distributed in source-code form and stipulates that any user may copy, modify, and distribute the software

to anyone else in source-code form. Users may, however, have to pay for their individual copies of GNU software.

The Free Software Foundation (FSF) is a tax-exempt charity that raises funds for work on the GNU Project. To find out more about the GNU Project, visit its home page at www.gnu.org. The home page is also where you can find information about how to contact the Free Software Foundation and how to help the GNU Project.

As a Linux user, you may not realize the extent to which all Linux distributions rely on GNU software. Nearly all the tasks you perform in a Linux system involve one or more GNU software packages. For example, the GNOME graphical user interface (GUI) and the command interpreter (that is, the `bash` shell) are both GNU software programs. By the way, the *shell* is the command-interpreter application that accepts the commands you type and then runs programs in response to those commands. If you rebuild the kernel or develop software, you do so with the GNU C and C++ *compiler* (which is part of the GNU software that accompanies Linux). If you edit text files with the `ed` or `emacs` editor, again you're using a GNU software package. The list goes on and on.



Table 1-2 lists some well-known GNU software packages that come with most Linux distributions. Depending on your interests, you may never need to use many of these packages, but knowing what they are in case you ever do need them is a good idea.

| <i>Software Package</i> | <i>Description</i> |
|-------------------------|--|
| <code>autoconf</code> | Generates shell scripts that automatically configure source-code packages. |
| <code>automake</code> | Generates <code>Makefile.in</code> files for use with <code>autoconf</code> . |
| <code>bash</code> | The default shell (command interpreter) in Linux. |
| <code>bc</code> | An interactive calculator with arbitrary-precision numbers. |
| <code>Binutils</code> | A package that includes several utilities for working with binary files: <code>ar</code> , <code>as</code> , <code>gasp</code> , <code>gprof</code> , <code>ld</code> , <code>nm</code> , <code>objcopy</code> , <code>objdump</code> , <code>ranlib</code> , <code>readelf</code> , <code>size</code> , <code>strings</code> , and <code>strip</code> . |
| <code>Coreutils</code> | A package that combines three individual packages called <code>Fileutils</code> , <code>Shellutils</code> , and <code>Textutils</code> and implements utilities such as <code>chgrp</code> , <code>chmod</code> , <code>chown</code> , <code>cp</code> , <code>dd</code> , <code>df</code> , <code>dir</code> , <code>dircolors</code> , <code>du</code> , <code>install</code> , <code>ln</code> , <code>ls</code> , <code>mkdir</code> , <code>mkfifo</code> , <code>mknod</code> , <code>mv</code> , <code>rm</code> , <code>rmdir</code> , <code>sync</code> , <code>touch</code> , <code>vdir</code> , <code>basename</code> , <code>chroot</code> , <code>date</code> , <code>dirname</code> , <code>echo</code> , <code>env</code> , <code>expr</code> , <code>factor</code> , <code>false</code> , <code>groups</code> , <code>hostname</code> , <code>id</code> , <code>logname</code> , <code>nice</code> , <code>nohup</code> , <code>pathchk</code> , <code>printenv</code> , <code>printf</code> , <code>pwd</code> , <code>seq</code> , <code>sleep</code> , <code>stty</code> , <code>su</code> , <code>tee</code> , <code>test</code> , <code>true</code> , <code>tty</code> , <code>uname</code> , <code>uptime</code> , <code>users</code> , <code>who</code> , <code>whoami</code> , <code>yes</code> , <code>cut</code> , <code>join</code> , <code>nl</code> , <code>split</code> , <code>tail</code> , and <code>wc</code> . |
| <code>cpio</code> | Copies file archives to and from disk or to another part of the file system. |
| <code>diff</code> | Compares files, showing line-by-line changes in several different formats. |

(continued)

Table 1-2 (continued)

| <i>Software Package</i> | <i>Description</i> |
|-------------------------|--|
| ed | A line-oriented text editor. |
| emacs | An extensible, customizable, full-screen text editor and computing environment. |
| Findutils | A package that includes the <code>find</code> , <code>locate</code> , and <code>xargs</code> utilities. |
| finger | A utility program designed to enable users on the Internet to get information about one another. |
| gawk | The GNU Project's implementation of the <code>awk</code> programming language. |
| gcc | Compilers for C, C++, Objective-C, and other languages. |
| gdb | Source-level debugger for C, C++, and Fortran. |
| gdbm | A replacement for the traditional <code>dbm</code> and <code>ndbm</code> database libraries. |
| gettext | A set of utilities that enables software maintainers to <i>internationalize</i> (make the software work with different languages such as English, French, and Spanish) a software package's user messages. |
| ghostscript | An interpreter for the PostScript and Portable Document Format (PDF) languages. |
| ghostview | An X Window System application that makes <code>ghostscript</code> accessible from the GUI, enabling users to view PostScript or PDF files in a window. |
| The GIMP | The GNU Image Manipulation Program, an Adobe Photoshop-like image-processing program. |
| GNOME | Provides a graphical user interface (GUI) for a wide variety of tasks that a Linux user may perform. |
| GNUchess | A chess game. |
| GNU C Library | For use with all Linux programs. |
| Gnumeric | A graphical spreadsheet (similar to Microsoft Excel) that works in GNOME. |
| grep package | Includes the <code>grep</code> , <code>egrep</code> , and <code>fgrep</code> commands, which are used to find lines that match a specified text pattern. |
| groff | A document formatting system similar to <code>troff</code> . |
| gtk+ | A GUI toolkit for the X Window System (used to develop GNOME applications). |
| gzip | A GNU utility for compressing and decompressing files. |

| <i>Software Package</i> | <i>Description</i> |
|-------------------------|---|
| <code>indent</code> | Formats C source code by indenting it in one of several different styles. |
| <code>less</code> | A page-by-page display program similar to <code>more</code> but with additional capabilities. |
| <code>libpng</code> | A library for image files in the Portable Network Graphics (PNG) format. |
| <code>m4</code> | An implementation of the traditional Unix macro processor. |
| <code>make</code> | A utility that determines which files of a large software package need to be recompiled, and issues the commands to recompile them. |
| <code>ncurses</code> | A package for displaying and updating text on text-only terminals. |
| <code>patch</code> | A GNU version of Larry Wall's program to take the output of <code>diff</code> and apply those differences to an original file to generate the modified version. |
| <code>rcs</code> | Revision Control System; used for version control and management of source files in software projects. |
| <code>sed</code> | A stream-oriented version of the <code>ed</code> text editor. |
| <code>Sharutils</code> | A package that includes <code>shar</code> (used to make shell archives out of many files) and <code>unshar</code> (to unpack these shell archives). |
| <code>tar</code> | A tape-archiving program that includes <i>multivolume support</i> — the capability to archive <i>sparse files</i> (files with big chunks of data that are all zeros), handle compression and decompression, and create remote archives — and other special features for incremental and full backups. |
| <code>texinfo</code> | A set of utilities that generates printed manuals, plain ASCII text, and online hypertext documentation (called <code>info</code>), and enables users to view and read online <code>info</code> documents. |
| <code>time</code> | A utility that reports the user, system, and actual time that a process uses. |

GUIs and applications

Face it — typing cryptic Linux commands on a terminal is boring. For average users, using the system through a *graphical user interface* (GUI, pronounced “GOO-ee”) — one that gives you icons to click and windows to open — is much easier. This is where the X Window System, or *X*, comes to the rescue.

X is kind of like Microsoft Windows, but the underlying details of how X works are different from Windows. X provides the basic features of displaying windows onscreen, but (unlike Microsoft Windows) it doesn't come with any specific look or feel for graphical applications. That look and feel comes from GUIs, such as GNOME and KDE, which make use of the X Window System.

Most Linux distributions come with the X Window System in the form of XFree86 or X.Org X11 — implementations of the X Window System for 80x86 systems. XFree86 and X.Org X11 work with a wide variety of video cards available for today's PCs.



Until early 2004, XFree86 from the XFree86 Project (www.xfree86.org) was the most commonly used X Window System implementation for x86 systems. However, around version 4.4, some changes to the XFree86 licensing terms caused concerns to many Linux and Unix vendors — they felt that the licensing terms were no longer compatible with the GNU General Public License (GPL). In January 2004, several vendors formed the X.Org Foundation (www.x.org) to promote continued development of an open source X Window System and graphical desktop. The first release of X.Org X11 uses the same code that was used by XFree86 4.4, up until the time when the XFree86 license changes precipitated the creation of X.Org Foundation.

As for the GUI, Linux distributions include one or both of two powerful GUI desktops: *KDE* (K Desktop Environment) and *GNOME* (GNU Object Model Environment). If both GNOME and KDE are installed on a PC, you can choose which desktop you want as the default — or switch between the two. KDE and GNOME provide desktops similar to those of Microsoft Windows and the Mac OS. GNOME also comes with the Nautilus graphical shell, which makes finding files, running applications, and configuring your Linux system easy. With GNOME or KDE, you can begin using your Linux workstation without having to know cryptic Linux commands. However, if you ever need to use those commands directly, all you have to do is open a terminal window and type the commands at the prompt.

Linux also comes with many graphical applications. One of the most noteworthy programs is *The GIMP* (The GNU Image Manipulation Program), a program for working with photos and other images. The GIMP's capabilities are on a par with those of Adobe Photoshop.

Although Linux used to lack in providing common productivity software — such as word processing, spreadsheet, and database applications — this situation has changed. Linux comes with the LibreOffice.org office productivity applications. In addition, you may want to check out the following prominent, commercially available office productivity applications for Linux:

- ◆ **Applicxware:** This office package is a good example of productivity software for Linux. You can find it at www.vistasource.com.

- ◆ **LibreOffice:** Forked from OpenOffice, LibreOffice (www.libreoffice.org) is a well-known productivity software package. The original OpenOffice is available from Apache and can be found at www.openoffice.org.
- ◆ **CrossOver Office:** From CodeWeavers (www.codeweavers.com/products/crossover-linux/download), CrossOver Office can be used to install your Microsoft Office applications (Office, for example) as well as several other Windows applications in Linux.

As you can see, there's no shortage of Linux office applications that are compatible with Microsoft Office.

Networks

Linux comes with everything you need to use the system in networks to exchange data with other systems. On networks, computers that exchange data must follow well-defined rules, or protocols. A *network protocol* is a method that the sender and receiver agree upon for exchanging data across a network. Such a protocol is similar to the rules you might follow when you're having a polite conversation with someone at a party. You typically start by saying hello, exchanging names, and then taking turns talking. That's about the same way network protocols work. The two computers use the same protocol to send bits and bytes back and forth across the network.

One of the best-known (and most popular) network protocols is Transmission Control Protocol/Internet Protocol (TCP/IP). TCP/IP is the protocol of choice on the Internet — the “network of networks” that spans the globe. Linux supports the TCP/IP protocol and any network applications that make use of TCP/IP.

Internet servers

Some popular network applications are designed to deliver information from one system to another. When you send electronic mail (e-mail) or visit websites using a web browser, you use these network applications (also called *Internet services*). Here are some common Internet services:

- ◆ **Electronic mail** (e-mail) that you use to send messages to any other person on the Internet using addresses such as `joe@someplace.com`
- ◆ **World Wide Web** (or simply, the web) that you browse using a web browser
- ◆ **News services**, where you can read newsgroups and post news items to newsgroups
- ◆ **File transfer utilities** that you can use to upload and download files
- ◆ **Remote login** that you can use to connect to and work with another computer (the remote computer) on the Internet — assuming you have the required username and password to access that remote computer

Any Linux PC can offer these Internet services. To do so, the PC must be connected to the Internet, and it must run special server software called *Internet servers*. Each of the servers uses a specific protocol for transferring information. For example, here are some common Internet servers that you find in Linux:

- ◆ `sendmail` is the mail server for exchanging e-mail messages between systems using SMTP (Simple Mail Transfer Protocol).
- ◆ Apache `httpd` is the web server for sending documents from one system to another using HTTP (HyperText Transfer Protocol).
- ◆ `vsftpd` is the server for transferring files between computers on the Internet using FTP (File Transfer Protocol).
- ◆ `innd` is the news server for distribution of news articles in a store-and-forward fashion across the Internet using NNTP (Network News Transfer Protocol).
- ◆ `in.telnetd` allows a user on one system to log in to another system on the Internet, using the TELNET protocol.
- ◆ `sshd` allows a user on one system to log in securely to another system on the Internet, using the SSH (Secure Shell) protocol.

Software development

Linux is particularly well suited to software development. Straight out the box, it's chock-full of software-development tools, such as the compiler and libraries of code needed to build programs. If you happen to know Unix and the C programming language, you'll feel right at home programming in Linux.

As far as the development environment goes, Linux has the same basic tools (such as an editor, a compiler, and a debugger) that you might use on other Unix workstations, such as those from IBM, Sun Microsystems, and Hewlett-Packard (HP).



If you work by day on one of these Unix workstations, you can use a Linux PC in the evening at home to duplicate that development environment at a fraction of the cost. Then you can either complete work projects at home or devote your time to software you write for fun and to share on the Internet.

Online documentation

As you become more adept at using Linux, you may want to look up information quickly — without having to turn the pages of (ahem) this great book, for example. Luckily, Linux comes with enough online information to jog your memory in those situations when you vaguely recall a command's name but can't remember the exact syntax of what you're supposed to type.



Stuff programmers want to know about Linux

These features make Linux a productive software-development environment:

- ✓ **GNU C compiler (gcc):** Compiles ANSI-standard C programs.
- ✓ **GNU C++ compiler (g++):** Supports ANSI-standard C++ features.
- ✓ **GNU compiler for Java (gcj):** Compiles programs written in the Java programming language.
- ✓ **GNU make utility:** Enables you to compile and link large programs.
- ✓ **GNU debugger (gdb):** Enables you to step through your program to find problems and to determine where and how a program failed. (The failed program's memory image is saved in the `core` file; `gdb` can examine this file.)
- ✓ **GNU profiling utility (gprof):** Enables you to determine the degree to which a piece of software uses your computer's processor time.
- ✓ **Subversion, Concurrent Versions System (CVS), and Revision Control System (RCS):** Maintains version information and controls access to the source files so that two programmers don't inadvertently modify the same source file at the same time.
- ✓ **GNU emacs editor:** Prepares source files and even launches a compile-link process to build the program.
- ✓ **Perl:** Enables you to write scripts to accomplish a specific task, tying together many smaller programs with Linux commands.
- ✓ **Tool Command Language and its graphical toolkit (Tcl/Tk):** Enables you to build graphical applications rapidly.
- ✓ **Python:** Enables you to write code in an interpreted programming language comparable to Perl and Tcl. (For example, the Fedora Core installation program, called `anaconda`, is written in Python.)
- ✓ **Dynamically linked, shared libraries:** Allows your actual program files to be much smaller because all the library code that several programs may need is shared — with only one copy loaded in the system's memory.

If you use Linux commands, you can view the manual page — commonly referred to as the *man page* — for a command by using the `man` command. (You do have to remember that command to access online help.)

You can also get help from the GUI desktops. Both GNOME and KDE desktops come with help viewers to view online help information. Most distributions include a help option in the desktop menu or a help icon on the desktop that you can use to get online help. You can then browse the help information by clicking the links on the initial help window. Figure 1-1 shows a typical help window — this one from Ubuntu's desktop.

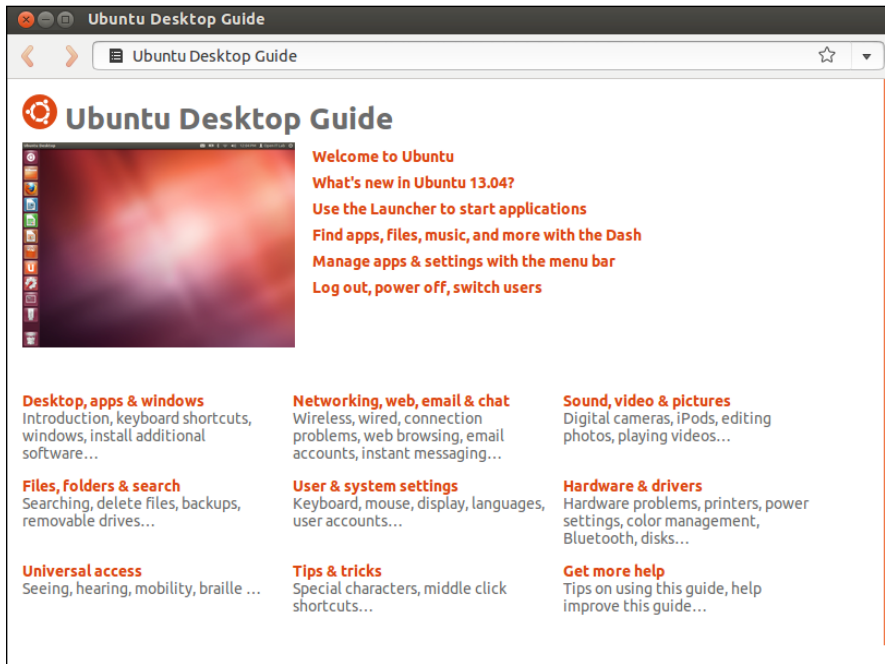

Figure 1-1: Online help is available from the GUI desktop.

Managing Your PC with Linux



As an operating system, Linux acts as the intermediary through which you — as the “lord of the system” — manage all the hardware. The hardware includes the system box, the monitor, the keyboard, the mouse, and anything else connected to the system box. The catchall term *peripheral* refers to any equipment attached to the system. If you use a laptop computer, all your hardware is packaged into the laptop.

Inside that system box is the system’s brain — the microprocessor (Intel Pentium 4, for example), also called the CPU — that performs the instructions contained in a computer program. When the microprocessor runs a computer program, that program’s instructions are stored in the memory, or *RAM* (random-access memory). This means that any part of the memory can be accessed randomly — in arbitrary order.

The system box has another crucial component — the hard drive (or *hard disk*, as it is sometimes called). The hard drive is the permanent storage space for computer programs and data. It’s permanent in the sense that the contents don’t disappear when you power off the PC. The hard drive is organized into files, which are in turn organized in a hierarchical fashion into directories and subdirectories (somewhat like organizing papers in folders in the drawers of a file cabinet).

To keep a Linux system running properly, you (or someone else) must make sure that the hardware is working properly and that the files are backed up regularly. There's also the matter of *security* — making sure that only legitimate people can access and use the system. These tasks are called *system administration*.

If you use Linux at a big facility with many computers, a full-time system administrator probably takes care of all system-administration tasks. On the other hand, if you run Linux on a home PC, you *are* the system administrator. Don't let the thought frighten you. You don't have to know any magic incantations or prepare cryptic configuration files to be a system administrator. Most Linux distributions include many graphical tools that make system administration a point-and-click job, just like running any other application.

Distribution media

Some Linux distributions come on a single DVD-ROM. After installation, the Linux kernel and all the applications are stored on your hard drive — which is where your PC looks first when you tell it to do something.

Typically, the hard drive is prepared to use Linux during the installation process. After that, you usually leave the hard drive alone except to back up the data stored there or (occasionally) to install and update applications.

Using CD-ROMs or DVD-ROMs in Linux is easy. While you're logged in at the GNOME or KDE desktop, just pop a CD or DVD in to the drive, and the system should automatically detect the DVD/CD-ROM. Depending on the Linux distribution, either a DVD/CD-ROM icon appears on the desktop or a file manager automatically opens and displays the contents of the DVD/CD-ROM. If all else fails, you can type a simple `mount` command to associate the DVD/CD-ROM with a directory on your system. This process of accessing the files on a CD or a DVD from Linux is called *mounting* the CD or the DVD.

Besides the hard drive and DVD/CD-ROM drive, of course, your PC may have other drives, such as a USB flash drive. Using those disks in Linux is also simple: You insert a disk or drive and double-click the icon that represents that medium on the GUI desktop. Doing so *mounts* the disk or drive so that you can begin using it.

Peripheral devices

Anything connected to your PC is a peripheral device, as are some components (such as sound cards) that are installed inside the system box. You can configure and manage these peripheral devices in Linux.

One of the common peripherals is a printer, typically hooked up to the USB (Universal Serial Bus) or parallel port of your PC. (Many distributions come with a graphical printer configuration tool that you can use to configure the printer.)

Another peripheral device that needs configuration is the sound card. Most Linux distributions detect and configure sound cards, just as Windows does. However, if Linux can't detect the sound card correctly, you may have to run a text mode or graphical tool to configure the sound card.

Linux configures other peripheral devices, such as the mouse and keyboard, at the time of installation. You can pretty much leave them alone after installation.

Nowadays PCs come with the USB interface; many devices, including printers and scanners, plug into a PC's USB port.



One nice feature of USB devices is that you can plug them into the USB port and unplug them at any time — the device doesn't have to be connected when you power up the system. These devices are called *hot plug* because you can plug in a device when the system is *hot*, meaning while it's running. Linux supports many hot plug USB devices. When you plug a device into the USB port, Linux loads the correct driver and makes the device available to applications.

File systems and sharing

The entire organization of directories and files is the *file system*. You can, of course, manage the file system using Linux. When you browse the files from the GNOME or KDE graphical desktop, you work with the familiar folder icons.



A key task in caring for a file system is to back up important files. In Linux, you can use the `tar` program to archive one or more directories on a USB drive or on other media. You can even back up files on a tape (if you have a tape drive). If you have a CD or DVD burner, you can also burn a CD or DVD with the files you want to back up or save for posterity.

Linux can also share parts of the file system with other systems on a network. For example, you can use the Network File System (NFS) to share files across the network. To a user on the system, the remote system's files appear to be in a directory on the local system.

Linux also comes with the Samba package, which supports file sharing with Microsoft Windows systems. Samba makes a Linux system work just like a Windows file or print server. You can also access shared folders on other Windows systems on your network.

Network

Now that most PCs are either linked in a local area network (LAN) or connected to the Internet, you need to manage your connection to the network as well. Linux comes with a network configuration tool to set up the LAN. For connecting to the Internet with a modem, there's usually a GUI Internet dial-up tool.

If, like many users, you connect to the Internet with DSL or cable modem, you need a PC with an Ethernet card that connects to the cable or DSL modem. It also means that you have to set up a local area network and configure the Ethernet card. Fortunately, these steps are typically a part of Linux installation. If you want to do the configurations later, you can by using a GUI network configuration tool.

Linux also includes tools for configuring a *firewall*, which is a protective buffer that helps keep your system relatively secure from anyone trying to snoop over your Internet connection. You can configure the firewall by using `iptables` commands or by running a GUI firewall-configuration tool.

Getting Started

Based on personal experience in exploring new subjects, I prescribe a four-step process to get started with Linux (and with *Linux All-in-One For Dummies*):

1. Install Linux on your PC (as shown in Book I — this one).
2. Configure Linux so that everything works to your liking (as shown in Book I).
3. Explore the GUI desktops and the applications (as shown in Book II).
4. Find out the details of specific subjects, such as Internet servers (as shown in Book IV).

In the rest of this chapter, I explain this prescription a bit more.

Step 1: Install

Microsoft Windows usually comes installed on your new PC, but Linux usually doesn't. So your first hurdle is to get Linux onto your PC. Although some vendors are now offering Linux pre-installed, this is still a rarity.

After you overcome that initial human fear of the unknown, I'll bet you find Linux fairly easy to install — but where do you *get* it in the first place? Well, the good news is that it's easily found online and Book I shows how to install Linux, step by step.



A typical complete Linux distribution is *huge* — but if you have good bandwidth, Linux is free to download. For example, you can visit the Linux Online website at www.linux.org and click the Download button.

Step 2: Configure

When you finish installing Linux, the next step is to configure individual system components (for example, the sound card and the printer) and tweak any needed settings. Book I shows how to configure the nooks and crannies of Linux.



If you aren't getting a graphical login screen, the X Window System may not have been configured correctly during installation. You have to fix the X configuration file for the GUI to work.

You may want to configure your GUI *desktop* of choice — GNOME or KDE (or both). Each has configuration tools. You can use these tools to adjust the look and feel of the desktop (background, title fonts, or even the entire color scheme). Book II shows how to make your desktop even more your own.

After you're through with configuration, all the hardware on your system and the applications should run to your liking.

Step 3: Explore

With a properly configured Linux PC at your disposal, you're ready to explore Linux itself. You can begin the process from the GUI desktop — GNOME or KDE — that you see after logging in. Look at the GUI desktops and the folders and files that make up the Linux file system, as discussed in Book II. You can also try out the applications from the desktop. You find office and multimedia applications and Internet applications to explore.

Also try out the shell: Open a terminal window and type some Linux commands in that window. You can also explore the text editors that work in text mode, as covered in Book II. Knowing how to edit text files without the GUI, just in case the GUI isn't available, is a good idea. At least you won't be helpless.

Step 4: Find out more

After you explore the Linux landscape and know what is what, you can dig deeper and find out more about specific subject areas. For example, you may be interested in setting up Internet servers. You can then learn the details of setting up individual servers, such as `sendmail` for e-mail, Apache for a web server, and the INN server for news, as covered in Book IV.

You can find out about many more areas, such as security, scripting, and system administration, as discussed in Books V, VI, and VII.

Of course, you can expect this step to go on and on, even after you have your system running the way you want it — for now. After all, learning is a lifelong journey.

Bon voyage!

Chapter 2: Installing Linux

In This Chapter

- ✓ Following the installation steps
- ✓ Checking Your PC's hardware
- ✓ Setting aside hard drive space for Linux
- ✓ Trying the Ubuntu Live CD
- ✓ Installing Linux on a flash drive

Most PCs come with Microsoft Windows pre-installed; if you want to use Linux, you usually have to install it.

You may feel a tad worried about installing a new operating system on your PC because it's a bit like brain surgery — or, rather, more like grafting a new brain because you can install Linux in addition to Microsoft Windows. When you install two operating systems like that, you can choose to start one or the other as you power up the PC. The biggest headache in adding Linux to a PC with Windows is creating a new *disk partition* — basically setting aside a part of the hard drive for Linux. The rest of the installation is routine — just a matter of following the instructions. If you want to try any of the Live CDs, you don't have to do any disk partitioning; just boot your PC from the Live CD. But first, take a deep breath and exhale slooowwwly. You have nothing to worry about.

Following the Installation Steps

Installing any Linux distribution involves a number of steps, and I will walk through them briefly, without the details. Then you can follow the detailed steps for the specific distributions and install what you want.



Some Linux distributions require that you have quite a bit of information about your PC's hardware on hand before installation. If you plan to install Debian, go ahead and gather information about your PC and its peripheral components before starting the installation. Luckily, most Linux installation programs can detect and work with most PC peripherals. Nevertheless, it's a good idea to figure out your PC's hardware so that you can troubleshoot in case something goes wrong with the installation.

The very first step is to burn the CD or DVD for your distribution. You can burn the CDs on any system that has a CD/DVD burner. (You must have a DVD burner if you want to burn a DVD, but a DVD burner can burn both CDs and DVDs.) Typically, if you already have a Windows PC with a CD/DVD burner, you can simply use that system to burn the CDs.



The second step is to make sure that your PC can boot from the DVD/CD drive. Most new PCs can boot directly from the DVD/CD drive, but some PCs may require your intervention. Typically, the PC may be set to boot from the hard drive before the DVD/CD drive, and you have to get into Setup to change the order of boot devices.

To set up a PC to boot from the DVD drive, you have to go into Setup as the PC powers up. The exact steps for entering Setup and setting the boot device vary from one PC to the next, but typically they involve pressing a key, such as F2. When the PC powers up, a brief message tells you what key to press to enter Setup. When you're in Setup, you can designate the DVD/CD drive as the boot device. After your PC is set up to boot from the DVD/CD drive, simply put the DVD or CD in the DVD/CD drive and restart your PC.



If you plan to try a Live CD distribution, the third step is to boot your PC from the Live CD or DVD. Otherwise the third step is to make room for Linux on your PC's hard drive. If you're running Microsoft Windows, this step can be easy or hard, depending on whether you want to replace Windows with Linux or keep both Windows and a Linux distribution.

If you want to install Linux without removing (or disturbing) Windows, remember that your existing operating system uses the entire hard drive. That means you have to *partition* (divide) the hard drive so that Windows can live in one part of it, and Linux can live in the other. Doing so can be a scary step because you run the risk of clearing the hard drive and wiping out whatever is on the drive. Therefore, *always* make a backup of your system before undertaking any significant changes.

To set aside space on your hard drive that the Linux installation program can use, you should use a partitioning program to help you create the partition. If your PC runs Windows 8, Windows 7, or Vista (as well as the much older XP, NT or 2000), you might want to invest in a commercial hard drive partitioning product. On the other hand, you can repartition your PC's hard drive by using a GUI (graphical user interface) tool called *QTParted*, which comes with Knoppix and a number of other distributions.



Note that the installers for some Linux distributions, such as openSUSE and Xandros Desktop, can automatically create partitions for Linux by reducing the size of a Windows partition. In that case, you don't need to use a tool such as QTParted to shrink the size of the existing Windows partition on your hard drive.

After you set aside a hard drive partition for Linux, you can boot the PC from the selected distribution's CD and start the Linux installation. Quite a few steps occur during installation, and they vary from one distribution to another. When you've come this far, it should be smooth sailing. Just go through the installation screens, and you'll be finished in an hour or two. Most installers, such as the openSUSE interface, display a GUI and guide you through all the steps.

One key step during installation involves partitioning the hard drive again, but this time you simply use the extra partition you created previously.

After a few configuration steps, such as setting up the network and the time zone, select the software packages to install and then let the installer complete the remaining installation chores. Some distributions make it even easier; they do away with the software-selection step. Instead, they install a default set of software packages.

At the end of the installation, reboot the PC. Rebooting is sometimes required as a part of the installation process before the automatic configuration can run.

When Linux runs for the first time, you get a chance to perform some more configuration steps and install additional software packages.

Checking Your PC's Hardware

If you're concerned that your PC may not be able to run Linux, here are some of the key components of your PC that you need to consider before you start the Linux installation:

- ◆ **DVD drive:** You must have a DVD drive (either DVD-ROM or DVD burner), and the PC must be able to boot from that drive.

The exact model doesn't matter. What does matter is how the DVD drive connects to the PC. Most new PCs have DVD drives that connect to the hard drive controller (*IDE*, for Integrated Drive Electronics, or *ATA*, for AT Attachment). If you add an external DVD drive, it most likely connects to the USB port. Any IDE/ATA or USB DVD drive works in Linux.

- ◆ **Hard drives:** Any IDE disk drive works in Linux. Another type of hard drive controller is SCSI (Small Computer System Interface), which Linux also supports. To comfortably install and play with Linux, you need about 5GB of hard drive space. On the other hand, to try the Live CD versions of Linux, you don't need any space on the hard drive.
- ◆ **Keyboard:** All keyboards work with Linux and the X Window System.

- ◆ **Monitor:** The kind of monitor isn't particularly critical except that it must be capable of displaying the screen resolutions that the video card uses. The screen resolution is expressed in terms of the number of picture elements (*pixels*), horizontally and vertically (for example, 1024 x 768). The installer can detect most modern monitors. If it doesn't detect your monitor, you can select a generic monitor type with a specific resolution (such as 1024 x 768). You can also specify the monitor by its make and model (which you can find on the back of the monitor).
- ◆ **Mouse:** The installation program can detect the mouse. All types of mouse (such as PS/2 or USB) work with Linux and the X Window System.
- ◆ **Network card:** Although not all PCs have network cards, these days it's rare to find one that does not. As long as yours has one, the installer can probably detect and use it. If you have problems, try to find the network card's make and model so you can search online for information about whether Linux supports that card.
- ◆ **Processor:** The processor speed, expressed in *MHz* (megahertz) or *GHz* (gigahertz), isn't that important as long as it's over 700 MHz; most processors made in the past few years have speeds well above that. As a general rule, the faster the better. Linux can run on other Intel-compatible processors, such as AMD and VIA processors.
- ◆ **RAM:** *RAM* is the amount of memory your system has. As with processing speed, the more RAM, the better. You need a minimum of 512MB to install both Linux and the X Window System. With some distributions, the minimum amount is higher, and you'll want still more memory to be able to run a GUI desktop comfortably.
- ◆ **SCSI controller:** Some high-performance PCs have SCSI controllers that connect disk drives and other peripherals to a PC. If your PC happens to have a SCSI controller, you might want to find out the make and model of the controller.
- ◆ **Sound card:** If your PC has a sound card and you want to have sound in Linux, you have to make sure it's compatible. You can configure the sound card after successfully installing Linux.
- ◆ **Video card:** Linux works fine with all video cards (also known as *display adapters*) in text mode, but if you want the GUI, you need a video card that works with the X Window System. The installer can detect a supported video card and configure the X Window System correctly. However, if the installer can't detect your video card, it helps if you know the make and model of the card.
- ◆ **Printer:** In addition to this hardware, you also need to find out the make and model of any printer you plan to use in Linux.



Many distributions, such as Debian GNU/Linux, work on any hardware that's compatible with the Linux kernel. For information on Linux-compatible hardware, see www.tldp.org/HOWTO/Hardware-HOWTO.



To check whether your PC's hardware is compatible with individual distributions, visit that vendor's site and find its hardware compatibility list.

Setting Aside Space for Linux

In a typical Windows PC, Windows is sitting on one big partition, taking over the entire hard drive. You want to shrink that partition and create room for Linux. During Linux installation, the installation program uses the free space for the Linux partitions.



To try out any of the Live CD distributions — such as Ubuntu — you don't have to repartition your hard drive. Just boot your PC from the Live CD. The installers can nondestructively shrink a Windows partition, so you don't need to perform the repartitioning step beforehand. If you plan to install Fedora, Debian, or any other Linux distribution on the hard drive, you have to repartition your hard drive. If you want to resize the disk partition under Windows, you can use a commercial product, or boot a Linux distribution and then use GParted, the partition editor, to resize the Windows partitions. GParted can resize NTFS (NT File System) partitions, which are used by most newer versions of Windows.



When you resize the disk partition, you always risk losing all the data on the hard drive. Therefore, before you resize hard drive partitions with a disk-partitioning tool, *back up your hard drive*. After making your backup — and before you do *anything* to the partitions — please make sure that you can restore your files from the backup.

After Ubuntu boots and the GUI desktop appears, follow these steps to reduce the size of the Windows partition:

- 1. Choose System → Administration → GParted from the Ubuntu desktop.**

The GParted window appears, and the tool displays the drives it finds on your PC. The first hard drive appears with a device name `/dev/sda`, the second one as `/dev/sdb`, and so on.

- 2. Click the hard drive from the list of devices on the right side of the GParted window.**

- 3. From the list of partitions, click the partition you want to resize.**

This partition would normally be the largest partition. For Windows 7, Vista, or XP, the partition type is `ntfs`, as shown in the Type column in the list of partitions. In a typical new PC, you might see two partitions — a smaller `fat16` partition and a large `ntfs` partition.

- 4. Choose Resize/Move from the GParted menu.**

The Resize partition dialog box appears.

5. Set the setting for the new size for the partition and then click Resize/Move.

You should choose a size such that you get 4GB or more free space after the partition. You'll see the size of the free space in the Free Space After field in the dialog box.

6. Click Apply to begin the operation after you have specified all changes you want to make. When the warning appears, click Apply and all pending operations will be performed.

The partition is changed, and you have free space after the Windows partition.

After you create free space on the hard drive for Linux, you can proceed to install the Linux distribution of your choice.

Trying a Live CD

Before you install anything, you'll find it worthwhile to try out a Live CD or bootable USB version. In addition to getting a feel for a Linux desktop, you can usually perform a few additional pre-installation chores.

To start Ubuntu, for example, boot your PC from the Live CD. A menu will appear from which you can enter various options to control the boot process or check your system to see if it meets hardware requirements. You should choose the default option of booting Ubuntu (this option is automatically performed if you don't make a selection before the menu times out in 30 seconds).

A few minutes later, you see the GNOME GUI desktop, which Ubuntu uses. You can now start exploring Ubuntu. If you click the `Examples` folder, you'll find a number of things that Ubuntu can do. You can also choose GParted (the partition editor) from the System, Administration menu (System⇨Administration⇨GParted) to reconfigure the hard drive.

When you finish using Ubuntu, choose System⇨Quit. After Ubuntu shuts down, remove the DVD and press Enter. Should you decide you want to install Ubuntu, click the Install icon on the desktop to begin the process.

Installing Linux on a Flash Drive

I was a fan of Live CD versions of Linux distributions for a while — but no more. I liked Live CDs because I could create cheap media that I could distribute to students and users so they could enjoy the Linux experience on their own machines without installing the operating system, changing what they were comfortable with, or risking doing harm. In addition, this same user group could quickly change from Fedora to Ubuntu to openSUSE and

more. My biggest dislikes of the Live CD distributions were their incredibly slow speed and the inability to save configuration changes easily. Given these substantial issues, I've been seeking a better solution. Thankfully, I've found it: bootable USB distributions.

Bootable USB distributions have been around for some time but have all had weaknesses that prevented me from embracing them. Fedora's Live USB implementation, however, is the best I've encountered. It provides a simple method for creation that most users can walk through unescorted, the installation process is nondestructive — allowing you to keep existing files on the USB drive — and retaining changes (data persistence) is straightforward.

In the rest of this chapter, I show you how to create a bootable flash drive and use it in your own setting.

Creating the bootable flash drive

Although you can create a bootable flash drive using a number of command-line methods in Linux, the simplest technique uses Windows. (I realize that it might sound like heresy to suggest making a Linux boot medium from Windows, but most users interested in a Live USB implementation of Linux probably run Windows.) Follow these steps to create a bootable flash drive:

1. **Go to** <http://fedorahosted.org/liveusb-creator> **and download the** `liveusb-creator` **program.**
2. **Install the** `liveusb-creator` **program.**
3. **Open the folder where** `liveusb-creator` **was installed.**
4. **Double-click the** `liveusb-creator` **program to run it.**
5. **Under Target Device, select the flash drive.**

For example, the flash drive may appear with a name such as TravelDrive.

6. **Choose where the image (the ISO file) will come from.**

If you have a slow Internet connection, you can have one Live CD from which you pull the ISO file. If you have a faster Internet connection, use the Download option to access a current ISO file.

7. **Set the Persistent Storage amount.**

This is the amount of storage space allocated to the installation that will always be available. I suggest a value of at least 300MB for the average user. (I don't know why this defaults to 0MB.)

8. **Click the Create Live USB button and sit back.**

You can watch the progress. Be prepared to wait ten minutes for the process to complete. Two folders are created on the drive: `syslinux` (less than 7MB and responsible for the booting) and `LiveOS` (the size depends on your storage setting).

9. **Close the application and test the newly created bootable drive.**

Troubleshooting the workstation

I experimented with a number of flash drives and failed to encounter a problem with any as long as 1GB of free space remained after the installation. Smaller drives (2GB or less) are often factory-formatted with FAT (file allocation table) and larger ones are formatted with FAT32; this did not make any difference in installation or usability that I could ascertain.

You must be sure that the workstation settings will allow the machine to boot from USB, which typically requires reconfiguring the BIOS.

1. **To begin, reboot the workstation and press the key that takes you to the BIOS configuration (usually F12 or DEL or sometimes F1 or F2).**
2. **Choose the Boot menu and enable the setting that reads Boot USB Devices First or something similar.**



On some computers, the flash drive is hidden under the hard drive section of the boot BIOS. In this case, you need to choose Boot → Hard Drives, change the primary hard drive to the storage media, and then make sure that the USB is the first choice listed under Boot Device. If the option to boot from USB is Enable/Disable, select Enable and then go to the order of boot devices and move the USB selection above the hard drive selection.

3. **Save your changes and exit the BIOS configuration.**

At this point, the workstation will continue with the reboot and — if your USB drive is plugged in — should boot Fedora.



If you get the single line entry `Boot Error` and nothing else happens, update the system BIOS per the manufacturer's instructions.

Working daily with the new drive

When your system boots, the Fedora environment will load much more quickly than it loads with Live CDs. The USB drive displays the new folders created on it, and other devices can be accessed as usual. The Install to Hard Drive icon remains on the desktop, allowing for a quick permanent transition to Fedora should you decide to do so.



To use the operating system, an Internet connection is not required but is strongly recommended because most users will want to download additional programs that allow them to test the operating system's functionality further.

Congratulations! You can now start using Fedora!

Chapter 3: Troubleshooting and Configuring Linux

In This Chapter

- ✓ Troubleshooting the installation
- ✓ Configuring the X Window System
- ✓ Resolving installation problems
- ✓ Setting up your printers
- ✓ Managing your DVDs and CD-ROMs
- ✓ Installing additional software packages

During the installation of Linux, the installer attempts to detect key hardware components, such as the SCSI controller and network card. According to what it detects, the installer takes you through a sequence of installation steps. For example, if the installer can't detect the network card, it skips the network configuration step. This is okay if you don't, in fact, have a network card — but if you do have one and the installer mistakenly insists that you don't, you have an installation problem on your hands.

Another installation problem can occur when you restart the PC and see not the graphical login screen but a text terminal. This error means that something is wrong with the X Window System configuration.

In addition, the Linux installation typically doesn't include configuration procedures for every piece of hardware on your PC system. For example, most installations don't set up printers during installation.

In this chapter, I show you some ways to troubleshoot installation problems. You find out how to configure X Window System to start with a GUI screen and how to configure a printer.

You may also have to install additional software packages; this chapter also walks through how you can install packages in different formats, such as the Red Hat Package Manager (RPM) and Debian package — the two formats in which most Linux software is distributed.

Using Text Mode Installation

Most Linux installers attempt to use the X Window System (X) to display the graphical installation screens. If, for instance, the installer fails to detect a video card, X does not start. If — for this reason or any other reason — the installer fails to start X, you can always fall back on a text mode installation. Then you can specify the video card manually or configure X later by using a separate configuration program. You can also configure X by editing its text configuration file.

Table 3-1 lists how you can get to the text mode installation screen. Typically, the text mode installation sequence is similar to that of the graphical installation outlined in Chapter 2 of this minibook. You respond to the prompts and perform the installation.

| Table 3-1 Text Mode Installation in Some Linux Distributions | |
|---|---|
| <i>Distribution</i> | <i>How to Get to the Text Mode Installer</i> |
| Debian | Runs in text mode by default. |
| Fedora | Type text at the <code>boot :</code> prompt after you start the PC from the Fedora CD or DVD. |
| Knoppix | Start Knoppix in text mode by typing knoppix 2 at the <code>boot :</code> prompt (because Knoppix is a Live distribution, you don't have to install it). |
| SUSE | At the first installation screen, press F3, use the arrow keys to select the text mode option, and then press Enter. |
| Ubuntu | Runs in text mode by default. |
| Xandros | Hold down the Shift key while booting the CD and select Rescue Console. When the <code>bash-3.00#</code> prompt appears, type quick_install and follow the instructions. |

Troubleshooting X

Every time I installed Linux on an older PC, the GUI installation worked fine during installation, but then the graphical login screen didn't appear when I rebooted the PC for the first time after installation. Instead, I ended up with a text login screen or a black screen with a small X in the middle, or the boot process seemed to hang with a gray screen. If this problem happens to you, here's how you can troubleshoot it:

1. Press Ctrl+Alt+Delete to reboot the PC.

The PC starts to boot. You get to a screen where GRUB (GRand Unified Bootloader) prompts you for the operating system to boot. (If the distribution uses LILO as the boot loader, you get a text prompt.)

2. **For GRUB, press the A key to add an option that tells the Linux kernel to boot to a prompt. For LILO, skip this step.**

The GRUB boot loader then displays a command line for the Linux kernel and prompts you to add what you want.

3. **For GRUB, type a space followed by the word single and press Enter. For LILO, type linux single and press Enter.**

The Linux kernel boots in a single-user mode and displays a prompt that looks like the following:

```
sh-3.00#
```

Now you're ready to configure X.

X uses a configuration file (XF86Config-4 or `xorg.conf`, depending on the distribution) to figure out your display card, your monitor, and the kind of screen resolution you want. The Linux installer prepares the configuration file, but sometimes the configuration isn't correct.

To quickly create a working configuration file, follow these steps:

1. **Type the following command:**

```
X -configure
```

The X server runs and creates a configuration file. The screen goes blank and then the X server exits after displaying some messages. In Fedora, the last line of the message says the following:

```
To test the server, run 'X -config ///etc/xorg.conf.new'
```

2. **Use a text editor, such as vi, to edit the ///etc/xorg.conf.new file and insert the following line after the line Section "Files":**

```
FontPath "unix/:7100"
```

In Fedora, you must also change `/dev/mouse` to `/dev/input/mice`.

3. **Type `xfs &` to start the X font server.**
4. **Try the new configuration file by typing the following line:**

```
X -config ///etc/xorg.conf.new
```

If you see a blank screen with an X-shaped cursor, the configuration file is working fine.

5. **Press `Ctrl+Alt+Backspace` to kill the X server.**
6. **Copy the new configuration file to the `/etc/X11` directory with the following command:**

```
cp ///etc/xorg.conf.new /etc/X11/xorg.conf
```

7. **Reboot the PC by pressing `Ctrl+Alt+Delete` or typing `reboot`.**

If all goes well, you should get the graphical login screen.



The X configuration file created by using the `-configure` option of the X server does not display at the best resolution. To fine-tune the configuration file, you have to run a utility to adjust the display settings after you reboot the system. Which utility you use depends on the Linux distribution, but most distributions include a utility that enables you to configure the video card, monitor, and display settings through a graphical user interface.

Resolving Other Installation Problems

I'm sure I haven't exhausted all the installation problems lurking out there. No one can. So many components in Intel x86 PCs exist that Murphy's Law practically requires that there be some combination of hardware that the installation program can't handle. In this section, I list a few known problems. For others, I advise you to go to Google Groups (<http://groups.google.com>) and type some of the symptoms of the trouble. Assuming that others are running into similar problems, you can get some indication of how to troubleshoot your way out of your particular predicament.

Using Knoppix boot commands

The Knoppix Live CD can be a great troubleshooting tool because Knoppix is good at detecting hardware and can be run directly from the boot medium (CD/DVD/USB).



If you have trouble starting Knoppix, try entering Knoppix boot commands at the `boot :` prompt. For example, if Knoppix seems to hang when trying to detect a SCSI card, you can disable SCSI probing by typing **knoppix noscsi** at the `boot :` prompt. Or, if you want the X server to load the *nv module* (for graphics cards based on the NVIDIA chipset), you can type **knoppix xmodule=nv** at the `boot :` prompt.

Table 3-2 lists some commonly used Knoppix boot commands.

| <i>Boot Command</i> | <i>What It Does</i> |
|--------------------------|---|
| <code>expert</code> | Starts in <i>expert mode</i> , which enables the user to interactively set up and configure Knoppix. |
| <code>failsafe</code> | Boots without attempting to detect hardware (except for the bare minimum needed to start Linux). |
| <code>fb1280x1024</code> | Uses fixed framebuffer graphics at the specified resolution (specify the resolution you want, such as 1024 x 768 or 800 x 600). |

| <i>Boot Command</i> | <i>What It Does</i> |
|---------------------------------------|--|
| <code>knoppix 1</code> | Starts Knoppix in run level 1 (single-user mode), which you can use to perform rescue operations. |
| <code>knoppix 2</code> | Starts at run level 2, which provides a text-mode shell prompt only. |
| <code>knoppix acpi=off</code> | Disables ACPI (Advanced Configuration and Power Interface) completely. |
| <code>knoppix atapiCd</code> | Uses the ATAPI CD-ROM interface instead of emulating a SCSI interface for IDE CD-ROM drives. |
| <code>knoppix desktop=wmname</code> | Uses the specified Window Manager instead of the default KDE desktop= <i>wmname</i> (where <i>wmname</i> is <code>fluxbox</code> , <code>icewm</code> , <code>kde</code> , <code>larswm</code> , <code>twm</code> , <code>wmaker</code> , or <code>xfce</code>). |
| <code>knoppix dma</code> | Enables direct memory access (DMA) for all IDE drives. |
| <code>knoppix floppyconfig</code> | Runs the shell script named <code>knoppix.sh</code> from a floppy. (The shell script contains Linux commands that you want to run.) |
| <code>knoppix fromhd=/dev/hda1</code> | Boots from a previously copied image of Live CD that's in the specified hard drive partition. |
| <code>knoppix hsync=80</code> | Uses an 80-kHz horizontal refresh rate for X. (Enter the horizontal refresh rate you want X to use.) |
| <code>knoppix lang=xx</code> | Sets the keyboard language as specified by the two-letter code <i>xx</i> (where <i>xx</i> is <code>cn</code> = Simplified Chinese, <code>de</code> = German, <code>da</code> = Danish, <code>es</code> = Spanish, <code>fr</code> = French, <code>it</code> = Italian, <code>nl</code> = Dutch, <code>pl</code> = Polish, <code>ru</code> = Russian, <code>sk</code> = Slovak, <code>tr</code> = Turkish, <code>tw</code> = Traditional Chinese, or <code>us</code> = U.S. English). |
| <code>knoppix mem=256M</code> | Specifies that the PC has the stated amount of memory (in megabytes). |
| <code>knoppix myconf=/dev/hda1</code> | Runs the shell script <code>knoppix.sh</code> from the <code>/dev/hda1</code> partition (enter the partition name where you have the <code>knoppix.sh</code> file). |
| <code>knoppix myconf=scan</code> | Causes Knoppix to search for the file named <code>knoppix.sh</code> , <code>scan</code> , and execute the commands in that file, if it exists. |

(continued)

Table 3-2 (continued)

| <i>Boot Command</i> | <i>What It Does</i> |
|--|--|
| <code>knoppix noeject</code> | Does not eject the Live CD after you halt Knoppix. |
| <code>knoppix noprompt</code> | Does not prompt to remove the Live CD after you halt Knoppix. |
| <code>knoppix nowheel</code> | Forces the PS/2 protocol for a PS/2 mouse or touchpad (as opposed to the mouse being detected automatically). |
| <code>knoppix noxxx</code> | Causes Knoppix to skip specific parts of the hardware detection (where <i>xxx</i> identifies the hardware or server that should not be probed: <code>apic</code> = Advanced Programmable Interrupt Controller, <code>agp</code> = Accelerated Graphics Port, <code>apm</code> = Advanced Power Management, <code>audio</code> = sound card, <code>ddc</code> = Display Data Channel, <code>dhcp</code> = Dynamic Host Configuration Protocol, <code>fstab</code> = file system table, <code>firewire</code> = IEEE 1394 high-speed serial bus, <code>pcmcia</code> = PC Card, <code>scsi</code> = Small Computer System Interface, <code>swap</code> = hard drive space used for virtual memory, <code>usb</code> = Universal Serial Bus). |
| <code>knoppix pci=bios</code> | Uses BIOS directly for bad PCI controllers. |
| <code>knoppix pnpbios=off</code> | Skips the Plug and Play (PnP) BIOS initialization. |
| <code>knoppix screen=resolution</code> | Sets the screen resolution in pixels (where <i>resolution</i> is the resolution you want, such as 1024x768, 800x600, 640x480, and so on). |
| <code>knoppix testcd</code> | Checks the data integrity of the Live CD by using the MD5 sum. |
| <code>knoppix tohd=/dev/hda1</code> | Copies the Live CD to the specified hard drive partition and runs from there (requires 1GB of RAM). |
| <code>knoppix toram</code> | Copies the Live CD to RAM (memory) and runs from there (requires 1GB of RAM). |
| <code>knoppix vga=ext</code> | Uses a 50-line text mode display. |
| <code>knoppix vsync=60</code> | Uses a vertical refresh rate of 60 Hz for X (enter the vertical refresh rate you want X to use). |
| <code>knoppix wheelmouse</code> | Enables the IMPS/2 protocol for wheel mice. |

| <i>Boot Command</i> | <i>What It Does</i> |
|-------------------------------------|---|
| knoppix xmodule= <i>modname</i> | Causes the X server to load the module specified by <i>modname</i> so that X works on your video card (where <i>modname</i> is <i>ati</i> , <i>fbdev</i> , <i>i810</i> , <i>mga</i> , <i>nv</i> , <i>radeon</i> , <i>savage</i> , <i>svga</i> , or <i>s3</i>). |
| knoppix xserver= <i>progname</i> | Starts the X server specified by <i>progname</i> (where <i>progname</i> is <i>XFree86</i> or <i>XFree86_SVGA</i>). |



When you want to issue multiple Knoppix boot commands, simply combine them in a single line. For example, to specify that you want to skip the SCSI auto detection, turn off ACPI, use the U.S. keyboard, use a wheel mouse, and require the X server to load the *nv* module, enter the following at the boot : prompt:

```
knoppix noscsi acpi=off lang=us wheelmouse xmodule=nv
```

The fatal signal 11 error

During installation, some people get a fatal *signal 11* error message, which stops the process cold. This error usually happens past the initial boot screen as the installer is starting its GUI or text interface. The most likely cause of a signal 11 error during installation is a hardware error related to memory or the cache associated with the CPU (microprocessor).



A signal 11, or SIGSEGV (short for Segment Violation Signal), error can occur in Linux applications. A *segment violation* occurs when a process tries to access a memory location that it's not supposed to access. The operating system catches the problem before it happens and stops the offending process by sending it a signal 11. When that happens during installation, it means the installer made an error while accessing memory, and the most likely reason is a hardware problem. A commonly suggested cure for the signal 11 problem is to turn off the CPU cache in the BIOS. To do so, you have to enter Setup while the PC boots (by pressing a function key, such as F2) and turn off the CPU cache from the BIOS Setup menu.

If the problem is due to a hardware error in memory (in other words, the result of bad memory chips), you can try swapping the memory modules around in their slots. You may also consider replacing an existing memory module with another memory module if you have one handy.

You can read more about the signal 11 problem at www.bitwizard.nl/sig11.

Getting around the PC reboot problem

On some PCs, when you press Enter at the boot prompt, the initial Linux kernel loads and immediately reboots the PC. This could be due to a bad implementation of ACPI in the PC's BIOS. To bypass the problem, type **linux acpi=off** at the boot prompt to turn off ACPI. If that doesn't work, consult Table 3-3 for other boot options that you might want to try.

Using Linux kernel boot options

When you boot the PC for Linux installation, either from the DVD or the first CD-ROM, you get a text screen with the `boot :` prompt. Typically, you press Enter at that prompt or do nothing, and the installation begins shortly. You can, however, specify a variety of options at the `boot :` prompt. The options control various aspects of the Linux kernel startup, such as disabling support for troublesome hardware or starting the X server using a specific X driver module. Some of these boot options can be helpful in bypassing problems that you may encounter during installation.

To use these boot options, typically you type **linux** followed by the boot options. For example, to perform text mode installation and tell the kernel that your PC has 512MB of memory, you type the following at the `boot :` prompt:

```
linux text mem=512M
```

Consult Table 3-3 for a brief summary of some of the Linux boot options. You can use these commands to turn certain features on or off.

| Table 3-3 | Some Linux Boot Options |
|--|---|
| <i>Boot Option</i> | <i>What It Does</i> |
| <code>allowcdma</code> | Enables DMA for CD/DVD drive. |
| <code>apic</code> | Works around a bug commonly encountered in the Intel 440GX chipset BIOS and only executes with the installation program kernel. |
| <code>acpi=off</code> | Disables ACPI in case there are problems with it. |
| <code>dd</code> | Prompts for a driver disk during the installation of Red Hat Linux. |
| <code>display=IP_ address:0</code> | Causes the installer GUI to appear on the remote system identified by the IP address. (Make sure that you run the command <code>xhost +hostname</code> on the remote system where <code>hostname</code> is the host where you run the installer.) |
| <code>driverdisk</code> | Prompts for a driver disk during the installation of Red Hat Linux. |
| <code>enforcing=0</code> | Turns off Security Enhanced Linux (SELinux) mandatory access control. |

| <i>Boot Option</i> | <i>What It Does</i> |
|--------------------------------------|--|
| <code>expert</code> | Enables you to partition removable media and prompts for a driver disk. |
| <code>ide=nodma</code> | Disables DMA on all IDE devices and can be useful when you're having IDE-related problems. |
| <code>ks</code> | Configures the Ethernet card using DHCP and runs a kickstart installation by using a kickstart file from an NFS server identified by the boot server parameters provided by the DHCP server. |
| <code>ks=<i>kickstartfile</i></code> | Runs a kickstart installation by using the kickstart file, specified by <i>kickstartfile</i> . (The idea behind kickstart is to create a text file with all the installation options and then kickstart the installation by booting and providing the kickstart file as input.) |
| <code>lowres</code> | Forces the installer GUI to run at a lower resolution (640 x 480). |
| <code>mediacheck</code> | Prompts you to check the integrity of the CD image (also called the ISO image). The image is checked by computing the MD5 checksum and comparing that with the official Fedora value. Checking a CD-ROM can take a few minutes. |
| <code>mem=<i>xxx</i>M</code> | Overrides the amount of memory that the kernel detects on the PC. (Some older machines could detect only 16MB of memory, and on some new machines, the video card may use a portion of the main memory.) Make sure you replace <i>xxx</i> with the number representing the megabytes of memory on your PC. |
| <code>nmi_watchdog=1</code> | Enables the built-in kernel deadlock detector that makes use of Non-Maskable Interrupt (NMI). |
| <code>noapic</code> | Prevents the kernel from using the Advanced Programmable Interrupt Controller (APIC) chip. (You can use this command on motherboards known to have a bad APIC.) |
| <code>nofirewire</code> | Does not load support for FireWire. |
| <code>noht</code> | Disables <i>hyper-threading</i> , which is a feature that enables a single processor to act as multiple virtual processors at the hardware level. |
| <code>nomce</code> | Disables self-diagnosis checks performed on the CPU by using Machine Check Exception (MCE). On some machines, these checks are performed too often and need to be disabled. |

(continued)

Table 3-3 (continued)

| <i>Boot Option</i> | <i>What It Does</i> |
|---------------------------------|--|
| <code>nomount</code> | Does not automatically mount any installed Linux partitions in rescue mode. |
| <code>nopass</code> | Does not pass the keyboard and mouse information to stage 2 of the installation program. |
| <code>nopcmcia</code> | Ignores any PCMCIA controllers in system. |
| <code>noprobe</code> | Disables automatic hardware detection and instead prompts the user for information about SCSI and network hardware installed on the PC. You can pass parameters to modules by using this approach. |
| <code>noshell</code> | Disables shell access on virtual console 2 (the one you get by pressing Ctrl+Alt+F2) during installation. |
| <code>nousb</code> | Disables the loading of USB support during the installation. (Booting without USB support may be useful if the installation program hangs early in the process.) |
| <code>nousbstorage</code> | Disables the loading of the <code>usbstorage</code> module in the installation program's loader. This option may help with device ordering on SCSI systems. |
| <code>reboot=b</code> | Changes the way the kernel tries to reboot the PC so that it can reboot even if the kernel hangs during system shutdown. |
| <code>pci=noacpi</code> | Causes the kernel to not use ACPI to route interrupt requests. |
| <code>pci=biosirq</code> | Causes the kernel to use BIOS settings to route interrupt requests (IRQs). |
| <code>rescue</code> | Starts the kernel in rescue mode, where you get a shell prompt and can try to fix problems. |
| <code>resolution=HHHxVVV</code> | Causes the installer GUI to run in the specified video mode (where <i>HHH</i> and <i>VVV</i> are standard resolution numbers, such as 640x480, 800x600, or 1024x768). |
| <code>selinux=0</code> | Disables the SELinux kernel extensions. |
| <code>serial</code> | Turns on serial console support during installation. |
| <code>skipddc</code> | Skips the Display Data Channel (DDC) probe of monitors. (This option is useful if probing causes problems.) |
| <code>vnc</code> | Starts a VNC (Virtual Network Computing) server so that you can control the GUI installer from another networked system that runs a VNC client. |



Although I mention these Linux kernel boot commands in the context of troubleshooting installation problems, you can use many of these commands anytime you boot a PC with any Linux distribution and you want to turn specific features on or off.

Setting Up Printers

In most Linux distributions, you can set up printers only after you install the distribution. The following sections outline the printer configuration steps for Ubuntu and are similar for all distributions.

To set up a printer, follow these steps:

1. **From the desktop, choose System Settings → Printers.**

If you're not logged in as `root`, the printer configuration tool prompts you for the `root` password. The printer configuration tool, shown in Figure 3-1, is called `system-config-printer`.

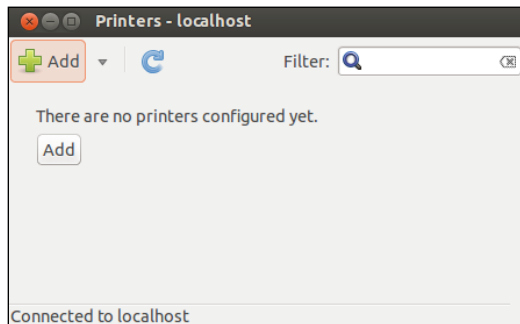
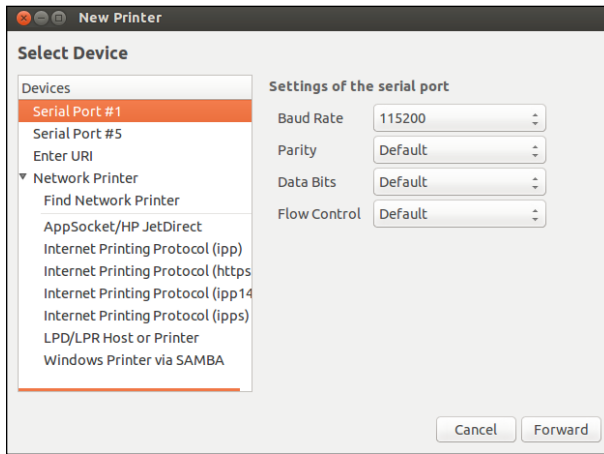

Figure 3-1:
The primary
printer con-
figuration
interface.

2. **Click the Add button to configure a new printer.**

If the device can be identified, it will appear in the list. If it can't be identified, you can still continue with the installation and manually add the drivers and configuration data needed. Figure 3-2 shows that the Epson Stylus printer is being connected to the serial port.

Figure 3-2: You can install a local printer or a network printer using the same interface.



3. Click Forward to continue.

The system searches for drivers and offers choices based on what it thinks you're installing.

In the following example, the host is connecting to a local printer.

4. Select the appropriate driver (see Figure 3-3), and then click Forward.

Figure 3-3: Choose the appropriate drivers to install.

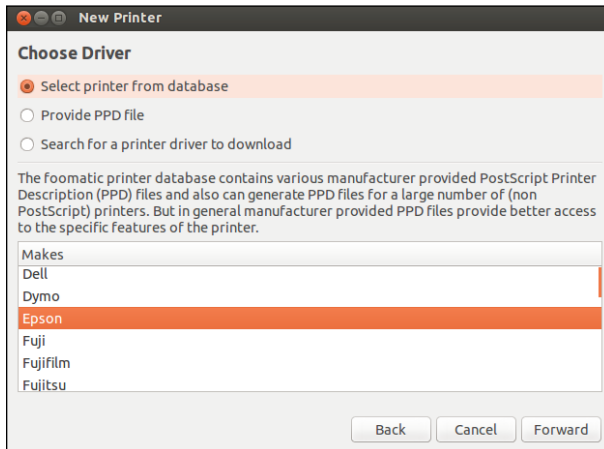

5. Enter the printer name and description variables (see Figure 3-4), and then click Apply.

Both the description and location variables are optional, but are helpful if you are configuring this for access by others across the network. Identifying the location can help users know where to pick up the reports they print.

Figure 3-4:
The only
required
configura-
tion value is
the printer
name.

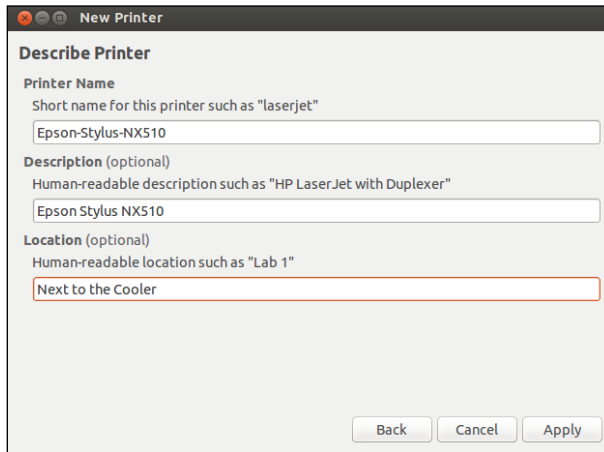

6. Print a test page to make sure all is working as it should.

Make any modifications to the settings as needed using the configuration options, which are shown in Figure 3-5.

Figure 3-5:
Edit the
configura-
tion with
the printer
configura-
tion tool.

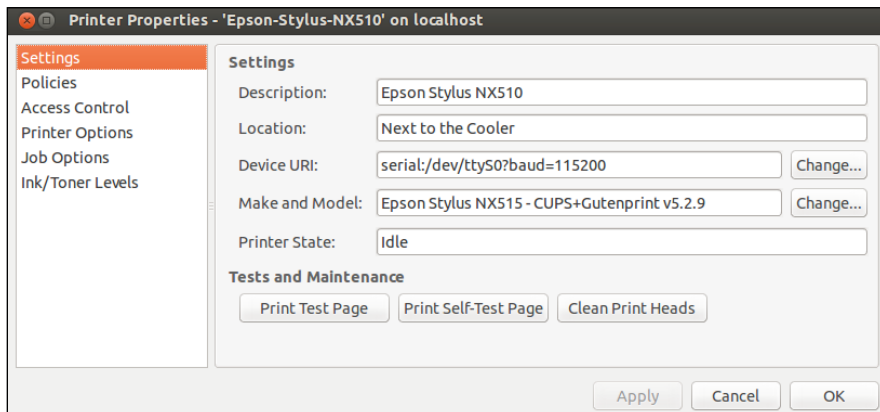

7. When the printer is configured as it should be, exit the printer configuration tool.

Managing DVDs, CD-ROMs, and Flash Drives

The GUI desktop makes using DVDs, CD-ROMs, and flash drives in Linux easy. Just place the external media in the drive, and an icon appears on the desktop.

You can then access the media by double-clicking the icon on the desktop. In some Linux distributions, the GUI automatically opens the contents of the media in a file-manager window soon after you insert the CD or DVD in the drive. To access the files and folders, you simply double-click the icons that appear in the GUI file manager window.

If you see an icon for the drive, right-click that icon for a context menu. From that menu, you can eject the media when you're finished.

Installing Other Software

The exact steps for installing software depend on the type of package in which the software is distributed. Most Linux software comes in either an RPM file or a Debian package file. The RPM files have an `.rpm` extension, and the Debian packages have a `.deb` extension.

Most distributions provide GUI installers to ease the process of installing new software packages. In this section, I provide a quick overview of adding software that applies to most distributions (you don't want to add software to Live distributions because Live distributions run from ROM and/or media that start fresh each time you boot).



Fedora and SUSE use RPM packages. Debian, Ubuntu, and Xandros are all Debian-based distributions, and as expected, they typically use Debian packages (also called DEB files). However, both RPM and DEB packages can be installed in any Linux distribution.

Installing software in Debian and Ubuntu

The best way to manage software packages in Debian and Debian-based distributions, such as Ubuntu, is to use *APT* — the Advanced Packaging Tool — which you usually control through the `apt-get` command.

When you install Debian, one of the last steps is to configure the sources for APT. The *APT sources* are the Internet servers (both FTP and web) where APT looks for software packages to download and install on your system. Assuming that APT is properly configured and that your system has a high-speed Internet connection, you can begin installing any package by typing the following command in a terminal window:

```
apt-get install pkgname
```

where *pkgname* is the name of the package that you want to install. If you don't know the package name, start by typing the following command in the terminal window:

```
apt-cache search keyword
```

where *keyword* is related to the package you want to install. For example, to search for a package that has the word *screenshot* in its description and also contains the word *KDE*, I'd type the following. (I use `grep` to search the output for occurrences of the text *KDE*.)

```
apt-cache search screenshot | grep KDE
```

This command then prints the following line as the result:

```
kssnapshot - Screenshot application for KDE
```

This shows that the `kssnapshot` package is what I need. If this package was not yet installed, I could then install it by typing the following command:

```
apt-get install kssnapshot
```

That, in a nutshell, is how you can use the command-line tools to look for and install packages in Debian.

Debian and older versions of Ubuntu also come with a GUI package installer for APT called *Synaptic Package Manager*, whose use is intuitive:



- ◆ **Debian:** Depending upon your version, you will either choose Applications⇄System Tools⇄Synaptic Package Manager from the GNOME desktop or Desktop⇄Administration⇄Synaptic Package Manager.
- ◆ **Ubuntu:** In old versions (pre 11.10), choose Select System⇄Administration⇄Synaptic Package Manager. When prompted for a password in Ubuntu, enter your normal user password because Ubuntu has no `root` user. In newer versions, you can download it with the following command:

```
sudo apt-get install synaptic
```

After Synaptic Package Manager starts, it displays a Quick Introduction dialog box that tells you, briefly, how to mark packages for installation, upgrade, or removal, and how to get to the menu to perform these actions. After reading the Introduction, click Close to get rid of that dialog box and access the Synaptic Package Manager.

In place of Synaptic you can use the Software & Updates tool, shown in Figure 3-6, to manage your software (click the Other Software tab to get started).

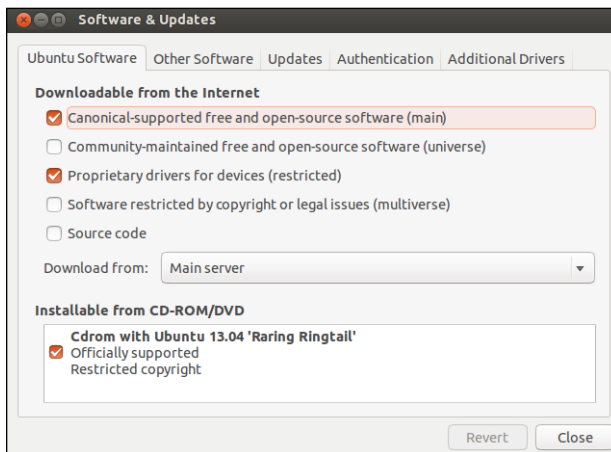

Figure 3-6:
The
Software
& Updates
Manager.

From here, you can choose to specify any software you want to download and install through APT, as shown in Figure 3-7.

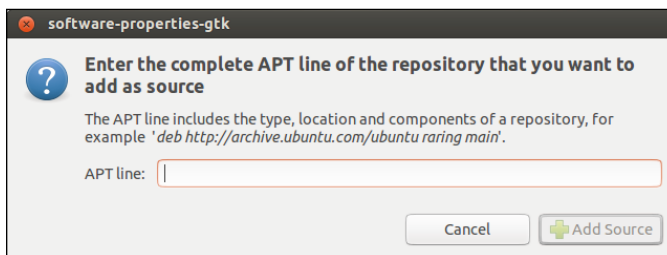

Figure 3-7:
Specify
what soft-
ware to
download
and install.

Using the Ubuntu Software Center, a feature similar to what is found in many other distributions as well, you can find just about everything you're looking for, as shown in Figure 3-8.

Installing software in Fedora

Most Fedora software comes in the form of RPM files. An *RPM* (Red Hat Package Manager) file is basically a single package that contains everything — all the files and configuration information — needed to install a software product.

From the GNOME desktop, you use the Add or Remove Software utility — a graphical utility for installing and uninstalling RPMs. Follow these steps:

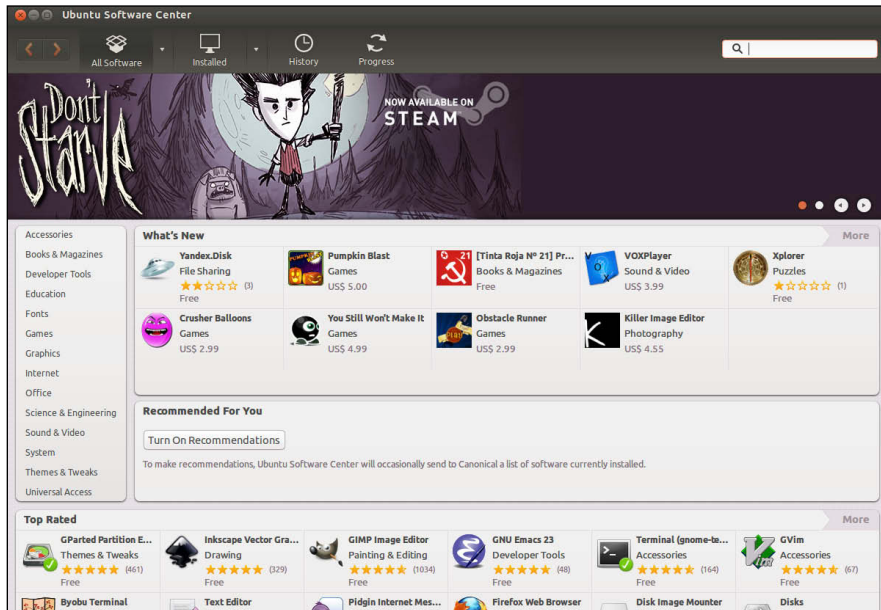

Figure 3-8:
The Ubuntu
Software
Center has
it all.

1. Choose System⇨Administration⇨Add/Remove Software.

If you're not logged in as `root`, a dialog box prompts you for the `root` password. The Add or Remove Packages utility starts and gathers information about the status of packages installed on your system. After it sorts through the information about all the installed packages, the utility displays the Package Manager dialog box, which contains a list of all the packages, as shown in Figure 3-9.

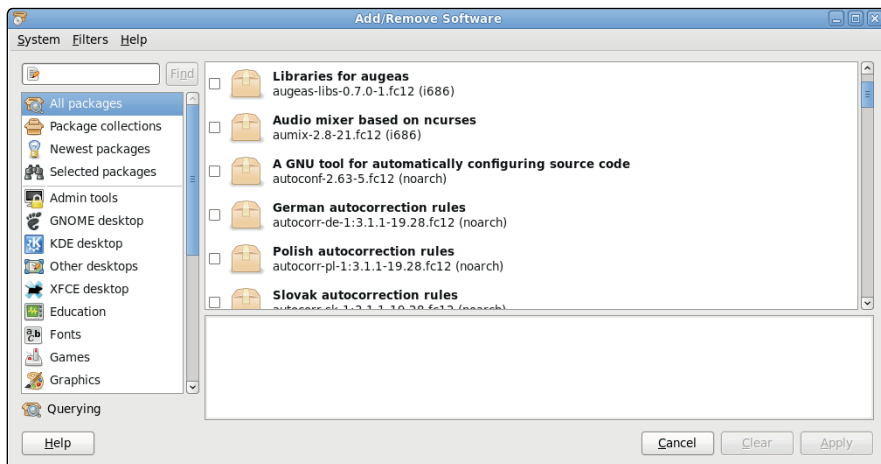

Figure 3-9:
Package
Manager
displays the
packages
available.



2. **To install an uninstalled package group, select the check box to the left of that package group's name.**

For partially uninstalled package groups, click the `Details` link (or the `Optional Packages` button) that appears in a column to the right of the package name.

A dialog box appears with details of the packages in the package group.

3. **In the dialog box, select the packages that you want to install or remove by clicking the names, and then click `Close` to exit the dialog box.**

You return to the Package Management dialog box, and if you added or removed any package, the `Update` (or `Apply`) button becomes active.

4. **Click the `Update` (or `Apply`) button to update the packages based on any additions or removals you made in the lists of packages.**

Installing software in SUSE

In SUSE, follow these steps to install or remove software:

1. **From the main menu, choose `YaST` to start the `YaST Control Center`.**

The `YaST Control Center` displays categories of tasks on the left side and specific tasks for that category on the right side.

2. **Click the `Software` category on the left side so that the right side shows the options for software.**

3. **Click the `Software Management` icon on the right side.**

`YaST` displays a new window where you can search for software packages.

4. **Search for a package by name or select a package by browsing available packages.**

To search for a package by name, type a keyword in the `Search` field in the upper-left corner of the window and then click `Search`. `YaST` displays the matching packages on the right side of the window. To browse for packages, click `Filter` in the upper-left corner, select `Package Groups` from the drop-down list, and click a group to see the list of individual packages in that group.

5. **Click the `Accept` button in the bottom-right corner to begin installing selected packages.**

`YaST` checks for *dependencies* — if a package requires other packages to install correctly — before installing packages. If you want to view what changes would occur when you click `Accept`, click `Filter` and select `Installation Summary`.

Installing software in Xandros

Xandros Desktop OS comes with Xandros Networks, which enables you to buy software online as well as install software from a CD or DVD. To start Xandros Networks, double-click the Xandros Networks icon on the Xandros Desktop. Xandros Networks starts, connects to a Xandros server, and displays information about installed, updated, and new applications.

To look at the list of new applications, click the plus sign to the left of the New Applications label on the left side of the Xandros Networks window. You get a further list of application categories. If you click a category, the right side of the window displays the names of packages within that category. You can then select a package or an entire category for installation.

To install any selected software packages, choose File⇨Enter Administrator Mode. You're prompted for the administrator (`root`) password. After entering the `root` password, you can choose File⇨Install Selected Applications. Xandros Networks checks for dependencies, prompts you if any further information is needed, and downloads and installs the new software.



If you've downloaded a Debian package, you can install it by choosing File⇨Install DEB File from the Xandros Networks menu. Similarly, the menu choice File⇨Install RPM File installs an RPM package.

Chapter 4: Trying Out Linux

In This Chapter

- ✓ Starting Linux and logging in
- ✓ Getting familiar with the shell
- ✓ Shutting down the system

You're sitting in front of your PC, about to turn it on. You know that the PC has Linux installed. (Maybe you did the installing yourself, but who's keeping track?) You're wondering what to expect when you turn it on and what you do afterward. Not to worry. If you're using Linux for the first time, this chapter shows you how to log in, check out the graphical desktops, try out some cryptic Linux commands, and finally, shut down the PC.



If you try out the Ubuntu Live distribution, all you have to do is boot from the flash drive/DVD/CD (as explained in Chapter 2 of this minibook), and you can try it just like any other Linux distribution.

For those of you who already know something about Linux, flip through this chapter to see if anything looks new. You never know what you may not know!

Starting Linux

When you turn on the PC, it goes through the normal power-up sequence and loads the boot loader — GRUB or LILO, depending on your Linux distribution and what you select during installation. The *boot loader* (once known as the bootstrap loader) is a tiny computer program that loads the rest of the operating system from the hard drive into the computer's memory. The entire process of starting a computer is called *booting*.



For Live distributions, the boot loader is typically ISOLINUX, a boot loader designed to work from an ISO 9660 CD-ROM.

The LILO and GRUB boot loaders display a graphical screen with the names of the operating systems that the boot loader can load. For example, if your PC has Windows and Linux, you see both names listed. You can then use the up- and down-arrow keys to select the operating system you want to use. If the PC is set up to load Linux by default, wait a few seconds, and the boot loader starts Linux. To be more precise, the boot loader loads the *Linux kernel* — the core of the Linux operating system — into the PC's memory.

Other boot loaders, such as ISOLINUX, may display a text `boot :` prompt at which you can type boot commands to load specific operating systems and to pass options to whichever operating system you load.

While the Linux kernel starts, you see a long list of opening messages, often referred to as the *boot messages*. (You can see these messages at any time by typing the command **dmesg** in a terminal window.) These messages include the names of the devices that Linux detects. One of the first lines in the boot messages reads

```
Calibrating delay loop . . . 4997.12 BogoMIPS
(lpj=2498560)
```

BogoMIPS is Linux jargon (explained in this chapter in a handy sidebar) for a measure of time. The number that precedes `BogoMIPS` depends on your PC's processor speed. The kernel uses the `BogoMIPS` measurement when it has to wait a small amount of time for some event to occur (such as getting a response back from a disk controller when it's ready).

After the boot messages appear, some Linux distributions (such as Fedora) switch to a graphical boot screen that shows information about the progress of system startup. When you boot some Linux distributions (such as Fedora and Xandros Desktop OS) for the first time after installation, you get a configuration program that guides you through some configuration steps, such as setting the date and time and adding user accounts. To complete such first-time configuration steps, all you have to do is enter the requested information.



After Linux boots, you typically get a graphical login screen. For some distributions, such as Knoppix, you get the desktop without having to log in as a user. On other Live distributions, you have to log in.

Figure 4-1 shows the Ubuntu desktop after I booted a PC from the Ubuntu Live distribution. For some distributions, you might be logged in automatically. For others, a graphical login screen will appear asking you to authenticate with the username and password given during (or at any time after) the installation.

Every distribution utilizes the `root` username, which happens to be the *superuser* (the administrator account). Whether you install Linux yourself or someone installs it for you, you need to know the `root` password. Without that, you can't do many of the tasks necessary to find out how Linux works.



You shouldn't normally log in as `root`. When you log in as `root`, you could accidentally damage your system because you can do anything when you're `root`. Always log in as a normal user. When you need to perform any task as `root`, type **su** - in a terminal window and enter the `root` password.

Figure 4-1:
The Ubuntu
Live
desktop.

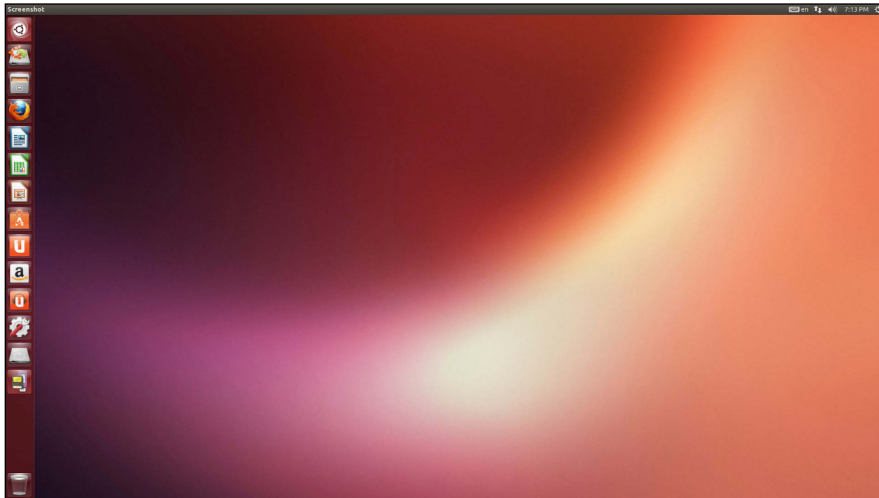

In Ubuntu, you define only a normal user account; Ubuntu doesn't give you the opportunity to define a `root` user account. Whenever you want to perform any tasks that require you to be `root`, you have to use the `sudo` command (an abbreviation for “superuser do”). The default password for `root` is the one you gave during the installation of the operating system.

What are BogoMIPS and LPJ?

When Linux boots, you get a message that says `Calibrating delay loop . . . 4997.12 BogoMIPS (lpj=2498560)`, with some number before the word *BogoMIPS*. BogoMIPS is one of those words that confounds new Linux users, but it's just jargon with a simple meaning.

BogoMIPS is Linus's invention (yes, the same Linus Torvalds who started Linux), and it means bogus MIPS. As you may know, *MIPS* is an acronym for *millions of instructions per second* — a measure of how fast your computer runs programs. Unfortunately, MIPS isn't a very good measure of performance; the MIPS measurements of different types of computers are difficult to compare accurately. BogoMIPS is basically a way to measure the computer's

speed that's independent of the exact processor type. Linux uses the BogoMIPS number to calibrate a *delay loop*, in which the computer keeps running some useless instructions until a specified amount of time passes. The reason for killing valuable processor time like this is to wait for some slowpoke device to get ready for work.

Oh . . . about *LPJ* — it's a recent term that stands for *loops per jiffy*, and it's another measure of time delay used by the kernel. The Linux kernel considers time in increments of jiffies, and a *jiffy* is defined as the time period that is equal to one second divided by the value of a kernel variable named `HZ`. In other words, `HZ` jiffies are in each second.

To log in as user `spiderman`, for example, type **spiderman** in the first text field and press Enter. (Move the cursor to the login dialog box before you begin typing.) Then type `spiderman`'s password and press Enter. You then see the initial graphical user interface (GUI). What you get depends on your choice of GUI — GNOME or KDE. If someone made the choice for you, don't worry — GNOME and KDE are both quite good and versatile.

Chapters 1 and 2 in Book II explore the GUI desktops — first GNOME and then KDE. This section focuses on the command line — the only interface you'll have access to if you experience problems loading a graphical desktop.

Playing with the Shell

Linux is basically Unix, and Unix just doesn't feel like Unix unless you can type cryptic commands in a text terminal. Although GNOME and KDE do a lot to bring us into the world of windows, icons, mouse, and pointer — affectionately known as *WIMP* — sometimes you're stuck with nothing but a plain text screen with a prompt that looks something like this (when you log in as `edulaney`):

```
edulaney@linux: /etc>
```

You see the text screen most often when something is wrong with the X Window System, which is essentially the machinery that runs the windows and menus that you normally see. In those cases, you have to work with the shell and know some cryptic Linux commands.

You can prepare for unexpected encounters with the shell by trying some Linux commands in a terminal window while you're in the GNOME or KDE GUI. After you get the hang of using the terminal, you might even keep a terminal window open so you can use one of those cryptic commands — simply because it's faster than pointing and clicking. Those two-letter commands do pack some punch!

Starting the bash shell

Simply put, the *shell* is the Linux *command interpreter* — a program that reads what you type, interprets that text as a command, and does what the command is supposed to do.

Before you start playing with the shell, open a terminal window. In either GNOME or KDE, the panel typically includes an icon that looks like a monitor. When you click that icon, what appears is a window with a prompt, like the one shown in Figure 4-2. That's a terminal window, and it works just like an old-fashioned terminal. A shell program is running and ready to accept any text that you type. You type text, press Enter, and something happens (depending on what you typed).

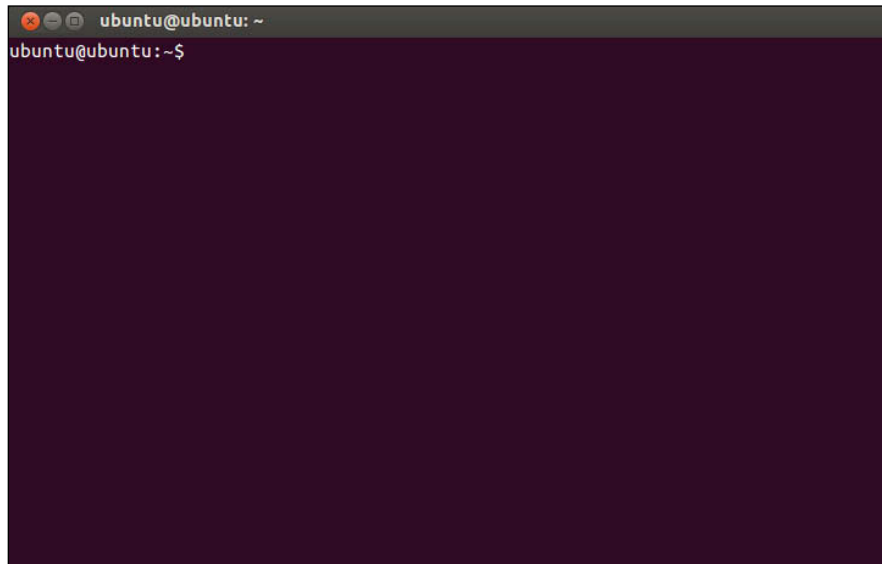

Figure 4-2:
The terminal
window
awaits your
input.



If the GNOME or KDE panel on your desktop doesn't seem to have an icon that starts a terminal or shell window, search through the Main menu hierarchy and you should be able to find an item labeled Console or Terminal. Choosing that item should then open a terminal window.

The prompt that you see depends on the shell that runs in that terminal window. The default Linux shell is `bash` (which stands for Bourne-Again SHell).

`bash` understands a host of standard Linux commands, which you can use to look at files, go from one directory to another, see what programs are running (and who else is logged in), and a whole lot more.

In addition to the Linux commands, `bash` can run any program stored in an executable file. `bash` can also execute *shell scripts* — text files that contain Linux commands.

Understanding shell commands

Because a shell interprets what you type, knowing how the shell figures out the text that you enter is important. All shell commands have this general format:

```
command option1 option2 . . . optionN
```

Such a single line of commands is commonly called a *command line*. On a command line, you enter a command followed by one or more optional parameters (or *arguments*). Such command-line options (or command-line arguments) help you specify what you want the command to do.

One basic rule is that you have to use a space or a tab to separate the command from the options — and to separate options from each other. If you want to use an option that contains embedded spaces, you have to put that option within quotation marks. For example, to search for two words of text in the password file, I enter the following `grep` command. (`grep` is one of those cryptic commands used to search for text in files.)

```
grep "WWW daemon" /etc/passwd
```

When `grep` prints the line with those words, it looks like the following. (What you see on your system may differ from what I show.)

```
wwwrun:x:30:8:WWW daemon apache:/var/lib/wwwrun:/bin/false
```

If you created a user account in your name, go ahead and type the `grep` command with your name as an argument but remember to enclose the name in quotes.

Trying a few Linux commands

While you have the terminal window open, try a few Linux commands just for fun. I will guide you through some examples to give you a feel for what you can do at the shell prompt.

To see how long the Linux PC has been up since you last powered it up, type the following. (**Note:** I show the typed command in bold, followed by the output from that command.)

```
uptime  
12:06:34 up 59 days, 16:23, 4 users, load average: 0.56, 0.55, 0.37
```

The part `up 59 days, 16:23` tells you that this particular PC has been up for nearly two months. Hmmm . . . can Windows do that?

To see what version of Linux kernel your system is running, use the `uname` command like this:

```
uname -srv
```

This runs the `uname` command with three options: `-s`, `-r`, and `-v` (which can be combined as `-srv`, as this example shows). The `-s` option causes `uname` to print the name of the kernel, `-r` prints the kernel release number, and `-v` prints the kernel version number. The command generates the following output on one of my Linux systems:

```
Linux 3.9.31.5-127.fc12.i686 #1 SMP Sat Nov 23 21:41:45 EST 2013
```

In this case, the system is running Linux kernel version 3.9.31.

To read a file, use the `more` command. For example, type `more /etc/passwd` to read the `/etc/passwd` file. The resulting output looks similar to the following:

```
root:x:0:0:root:/root:/bin/bash
bin:x:1:1:bin:/bin:/bin/bash
daemon:x:2:2:Daemon:/sbin:/bin/bash
lp:x:4:7:Printing daemon:/var/spool/lpd:/bin/bash
mail:x:8:12:Mailer daemon:/var/spool/clientmqueue:/bin/false
news:x:9:13:News system:/etc/news:/bin/bash
uucp:x:10:14:Unix-to-Unix Copy system:/etc/uucp:/bin/bash
. . . lines deleted . . .
```

To see a list of all the programs currently running on the system, use the `ps` command, like this:

```
ps ax
```

The `ps` command takes many options, and you can provide these options without the usual dash prefix. This example uses the `a` and `x` options. The `a` option lists all processes that you're running, and the `x` option displays the rest of the processes. The result is that `ps ax` prints a list of all processes running on the system, as shown in the following sample output of the `ps ax` command:

```
PID TTY STAT TIME COMMAND
1 ? S 0:01 init [5]
2 ? SN 0:00 [ksoftirqd/0]
3 ? S< 0:00 [events/0]
4 ? S< 0:00 [khelper]
9 ? S< 0:00 [kthread]
22 ? S< 0:00 [kblockd/0]
58 ? S 0:00 [kapmd]
79 ? S 0:00 [pdflush]
80 ? S 0:00 [pdflush]
82 ? S< 0:00 [aio/0]
. . . lines deleted . . .
5325 ? Ss 0:00 /opt/kde3/bin/kdm
5502 ? S 0:12 /usr/X11R6/bin/X -br -nolisten tcp :0 vt7 -auth
/var/lib/xdm/authdir/authfiles/A:0-p1AOrt
5503 ? S 0:00 -:0
6187 ? Ss 0:00 /sbin/portmap
6358 ? Ss 0:00 /bin/sh /usr/X11R6/bin/kde
6566 ? Ss 0:00 /usr/sbin/cupsd
6577 ? Ss1 0:00 /usr/sbin/nscd
. . . lines deleted . . .
```

Amazing how many programs can run on a system even when only you are logged in as a user, isn't it?

As you can guess, you can do everything from a shell prompt, but it does take some getting used to.

Shutting Down

When you're ready to shut down Linux, you must do so in an orderly manner. Even if you're the sole user of a Linux PC, several other programs usually run in the background. Also, operating systems, such as Linux, try to optimize the way that they write data to the hard drive. Because hard-drive access is relatively slow (compared with the time needed to access memory locations), data generally is held in memory and written to the hard drive in large chunks. Therefore, if you simply turn off the power, you run the risk that some files aren't updated properly.

Any user (you don't even have to be logged in) can shut down the system from the desktop or from the graphical login screen, although some distributions, such as Debian, prompt you for the `root` password. Choose Main Menu⇨Log Out (or look for a Log Out option in the menus). A Log Out dialog box appears, such as the one shown in Figure 4-3, providing options for rebooting, halting the system, or simply logging out. To shut down the system, simply select Shutdown and click OK. The system then shuts down in an orderly manner.

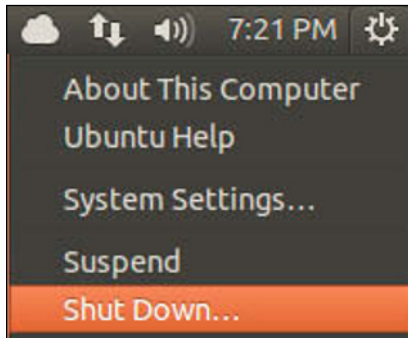

Figure 4-3:
The Log Out
dialog box.

If the logout menu doesn't have an option to shut down, first log out and then select Shutdown from the graphical login screen. You can also shut down a Linux computer from a terminal with the command `init 0`. This method is sometimes required if you are running the operating system within a virtual software manager such as VMWare.

While the system shuts down, you see messages about processes shutting down. You may be surprised at how many processes there are even when no one is explicitly running any programs on the system. If your system doesn't automatically power off on shutdown, you can manually turn off the power.



Shutting down or rebooting the system may *not* require `root` access. This is why it's important to make sure that physical access to the console is protected adequately so that anyone who wants to can't simply walk up to the console and shut down your system.



You don't always need to shut down when you're finished with a session; instead, you may choose to simply log out. To log out of KDE, choose **Main Menu**⇨**Logout**. You can also right-click an empty area of the desktop and choose **Logout** from the context menu that appears. To log out from GNOME, choose **System**⇨**Log Out**. Click **OK** when a dialog box asks if you really want to log out. (In some GNOME desktop distributions, the menu option to log out is the second or third menu button from the left in the top panel.)

Book II

Linux Desktops

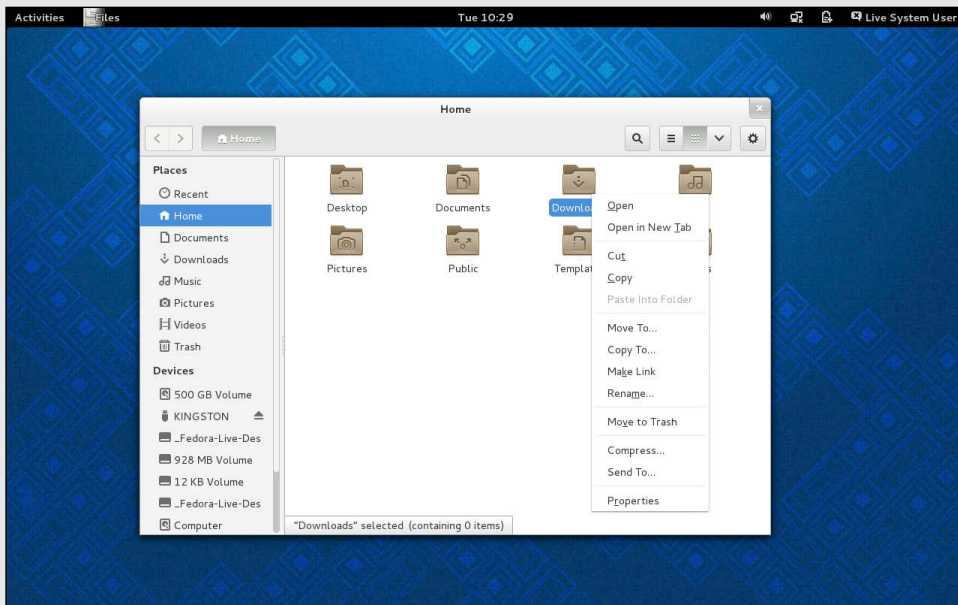

Visit www.dummies.com/extras/linuxaio for great Dummies content online.

Contents at a Glance

| | |
|--|------------|
| Chapter 1: GNOME, Unity, Cinnamon, and MATE | 69 |
| Getting to Know the GNOME Desktop..... | 70 |
| Understanding the GNOME Panels | 71 |
| Looking at Unity..... | 74 |
| Looking at Cinnamon..... | 75 |
| Looking at MATE | 76 |
| Chapter 2: The KDE Desktop | 79 |
| Getting to Know the KDE Desktop..... | 79 |
| Understanding the KDE Panel | 82 |
| Configuring the KDE Bottom Panel | 85 |
| Configuring the KDE Desktop..... | 86 |
| Chapter 3: Commanding the Shell | 89 |
| Opening Terminal Windows and Virtual Consoles..... | 89 |
| Using the bash Shell..... | 90 |
| Discovering and Using Linux Commands | 98 |
| Writing Shell Scripts | 106 |
| Chapter 4: Navigating the Linux File System | 109 |
| Understanding the Linux File System | 109 |
| Navigating the File System with Linux Commands | 114 |
| Chapter 5: Introducing Linux Applications | 127 |
| Taking Stock of Linux Applications..... | 127 |
| Introducing Office Applications and Tools | 128 |
| Checking out Multimedia Applications | 133 |
| Using Graphics and Imaging Apps | 136 |
| Chapter 6: Using Text Editors | 139 |
| Using GUI Text Editors | 139 |
| Text Editing with ed and vi..... | 141 |

Chapter 1: GNOME, Unity, Cinnamon, and MATE

In This Chapter

- ✓ **Discovering GNOME's common features**
- ✓ **Understanding the GNOME panels**
- ✓ **Looking at Unity**
- ✓ **Exploring Cinnamon**
- ✓ **Finding a MATE**

In the days of old, Linux distributions used to come with one or both of two popular graphical user interfaces (GUIs): GNOME and KDE. GNOME and KDE are similar to Microsoft Windows but unique in one respect: Unlike Microsoft Windows, you can choose your GUI in Linux. If you don't like GNOME, you can use KDE; and if you don't like KDE, you can use GNOME. With both installed, you can switch between the two in a matter of seconds. Try doing that with Microsoft Windows!

Today, that basic choice is often still the case, with one big exception: GNOME has given birth to a number of different variants. You'll find GNOME widely used, but you'll also find that some distributions like to include desktops like Unity, Cinnamon, and MATE. When you encounter them, just know that they started as GNOME and were altered to fit some specific purposes. They have the same basic structure; we walk through them here.



GNOME and KDE were developed independently of Linux, and they run on other UNIX operating systems besides Linux. You also have the option to install other GUIs, such as FVWM and Xfce, in Linux. Visit www.freedesktop.org/wiki/Desktops to see a list of other X desktops (desktops that run on X Window System).

This chapter explores the major features of GNOME and its variants; Chapter 2 in this minibook does a similar comparison of KDE. You can best figure out these GUIs by simply starting to use them. No matter which GUI you decide to use, all GUI applications — whether they're based on GNOME or KDE — run on all GUI desktops. In other words, you can run KDE applications under GNOME and vice versa. The only hurdle is that sometimes both GNOME and KDE applications may not be installed by default.



Each Linux distribution typically installs one GUI by default. Each distribution also customizes that GUI to create a desktop that's unique to the distribution. Because of this, there may be subtle, minor differences between what you see in your distribution and what is described here.

Getting to Know the GNOME Desktop

The initial desktop for GNOME looks like any other popular GUI, such as Microsoft Windows or the Mac OS X desktop. Figure 1-1, for example, shows the typical GNOME desktop.

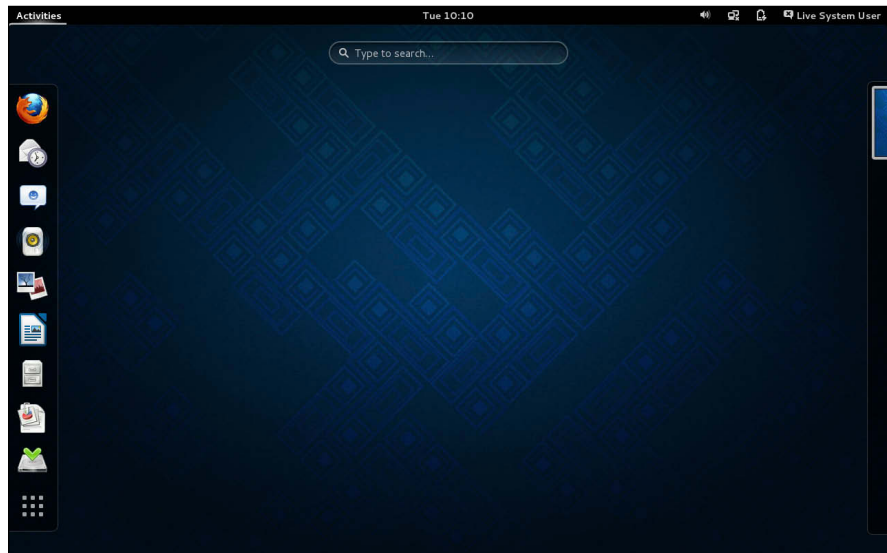

Figure 1-1:
A clean
GNOME
desktop in
Fedora.

Running the Live distribution, a number of icons that would be present if the operating system were installed will not be there. When the system is installed, the desktop initially shows icons for your computer, your home folder, and the trash can for deleted files. Unlike some other distributions, Fedora strives for a minimum of desktop icons and has a clean look.

The GNOME desktop displays a context menu when you right-click an object or anywhere on the desktop. Depending on where you click, the menu can offer the following :

- ◆ **New Folder** to create a new folder in a directory
- ◆ **Properties** to see the properties, including permissions, associated with a file or folder
- ◆ **Open** to open a folder or file

- ◆ **Compress** to reduce the size of the file
- ◆ **Make Link** to create a shortcut

Figure 1-2 shows the context menus in a typical GNOME folder. If there are any menu options with a right-pointing arrow, it indicates that they have other menus that appear when you put the mouse pointer over the arrow.

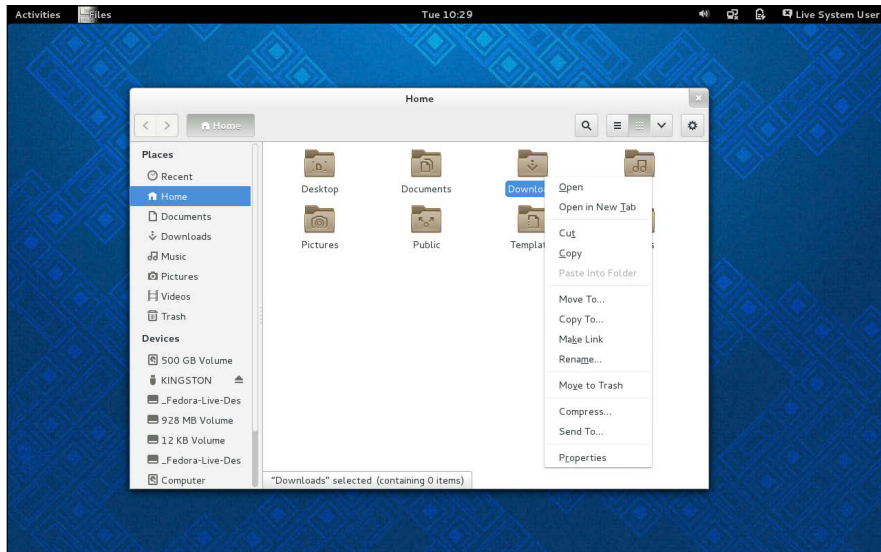

Figure 1-2:
Standard
menu
choices in
GNOME for
a folder.

Many items on this context menu are the same no matter what icon you click, but right-clicking certain icons (for example, the Trash icon) produces a somewhat different menu. For the Trash icon, the icon context menu typically provides an option to permanently delete the items in the trash. (You get a chance to say Yes or No.)



I bet you see a pattern here: the right-click. No matter where you are in a GUI desktop, *always right-click before you pick*. You're bound to find something useful when you right-click!

Understanding the GNOME Panels

LX0-102
Exam

The GNOME desktop has *panels* and each panel is similar to the Windows taskbar. The top panel has menu choices on the left, a time display in the center, and icons for common choices on the right. Between the left menu and the time, the panel shows any applications you've started (or that were automatically started for you).

The top panel

The top panel is the long bar that stretches across the top of the GNOME desktop. Figure 1-3 shows a typical view of the GNOME top panel.

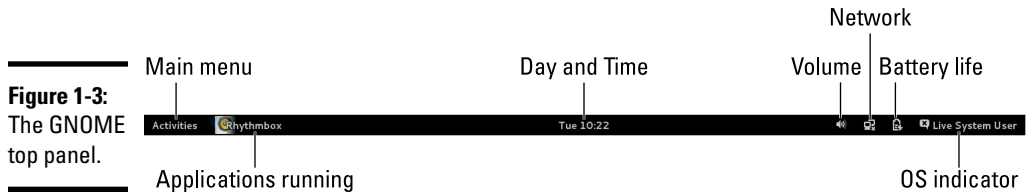

The panel is a parking place for icons. Some icons start programs when you click them. Some show status (for example, what programs are currently running) as well as information such as date and time.

The desktop



After you choose Activities, the leftmost area of the desktop in GNOME shows the applications that can be opened in a panel that you can think of as the *Main Menu*. The Main Menu panel, like the Start button in Microsoft Windows, is where you typically find all your applications, organized into submenus. Figure 1-4 shows an example of this, again from Fedora.

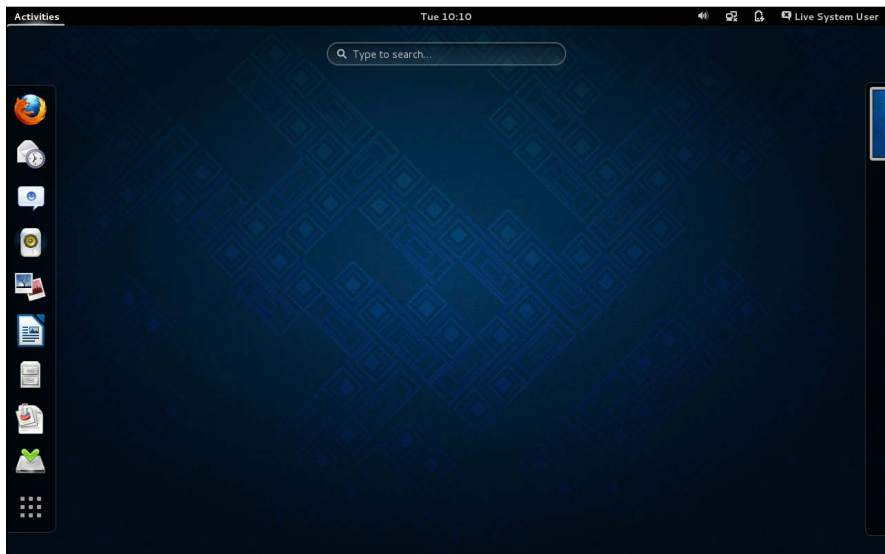

Figure 1-4:
The GNOME desktop.

In the case of the Live distribution version of Fedora, the default icons on this main menu (also known as the Favorites menu) represent the following features:

- ◆ Firefox web browser
- ◆ Evolution email package
- ◆ Empathy contact manager
- ◆ Rhythmbox
- ◆ Shotwell
- ◆ LibreOffice Writer
- ◆ Shortcut to your files
- ◆ Shortcut to your documents
- ◆ Install icon
- ◆ Link to your recent applications

You can click any icon to start the application associated with it, or right-click to start it in a new window or remove it from the menu.



Chapter 5 of this minibook looks at applications, including the Firefox web browser and others discussed here.

On the right side of the desktop, you'll see a quick method of accessing your various desktops — the Workplace Switcher. Assume, for example, that you're working on a number of projects at once. You can bounce between them by choosing Activities, and then moving your mouse over to the panel on the right so it automatically expands to show you your options (as illustrated by Figure 1-5).

The bottom panel

In addition to the top panel, GNOME also includes a bottom panel. It does not appear onscreen by default (unlike the arrangement in KDE), but you can use it to find important information. Figure 1-6 is an example of this panel, showing three important notifications from the system and a link to a USB drive.



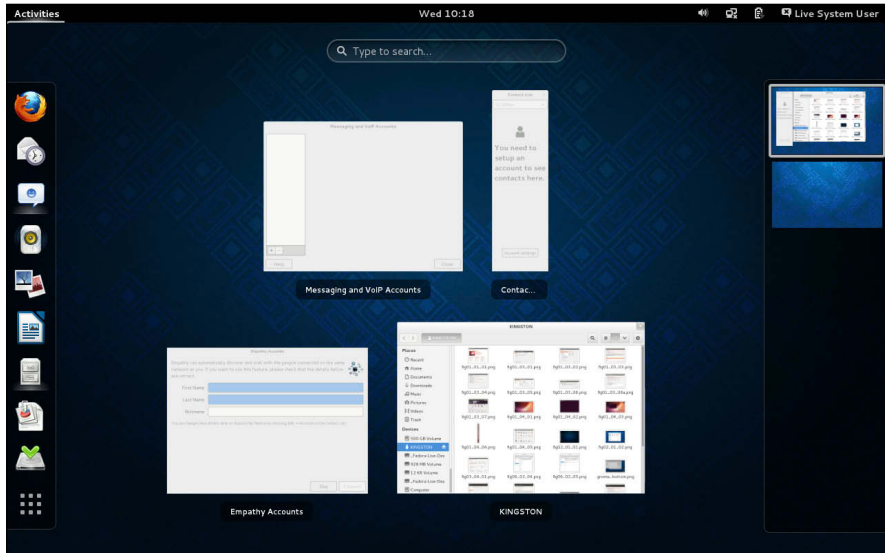

Figure 1-5:
Choose between desktops.



Figure 1-6:
The bottom panel in GNOME.

Looking at Unity

Just as there are differences among Windows desktops from Windows XP to versions 7 and 8, so too the GNOME desktop has variations. The first of these is Unity — which, while available for other distributions, is most closely associated with Ubuntu. Figure 1-7 shows an example of this desktop.

Unity was created by Canonical and Mark Shuttleworth (respectively the organization behind — and the head of — Ubuntu). Notice that the same clean desktop look of GNOME prevails. What differs is that the makers of Unity strive to make it as easy as possible for a user with no previous knowledge to use — and that makes it ideal for netbooks as well as desktops. Figure 1-8 shows an example of the desktop with a terminal window open and the drop-down menu displayed.

Figure 1-7:
The Unity desktop is based on GNOME.

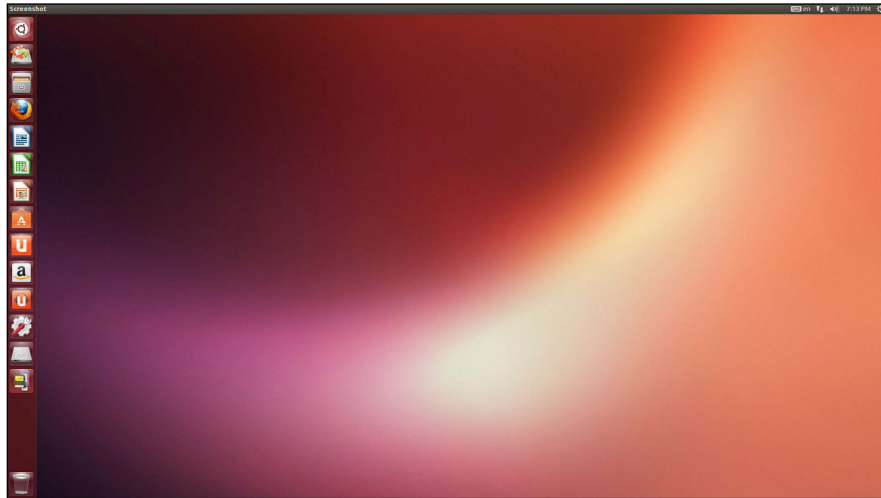
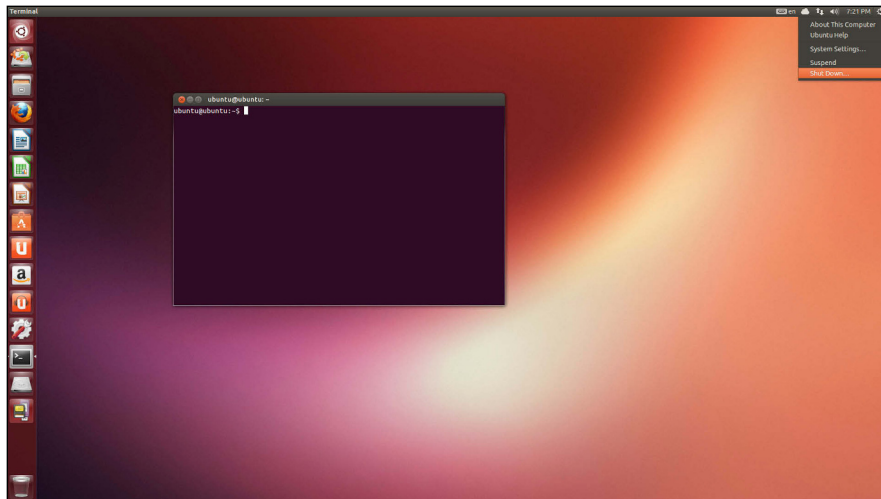

Figure 1-8:
The Unity desktop focuses on simplicity.



One of the biggest pluses behind this desktop is that Unity is touch-ready.

Looking at Cinnamon

The Cinnamon desktop looks much like GNOME used to look several versions ago. Figure 1-9 shows an example of it in Linux Mint. Notice how similar this looks to Windows of the XP era.

Figure 1-9:
The
Cinnamon
desktop
resembles
Windows.

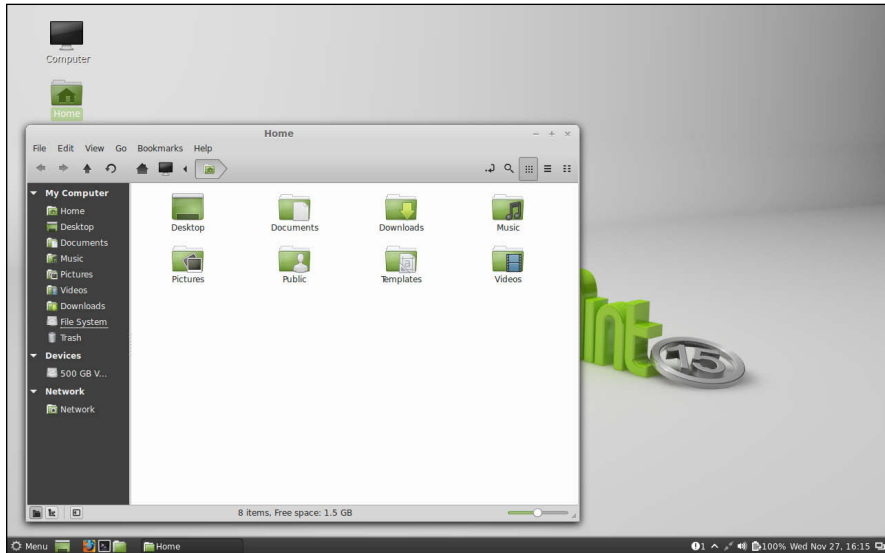

The leftmost icon on the bottom panel is the *Main Menu* button. The Main Menu button, like the Start button in Microsoft Windows, is where you typically find all your applications, organized into submenus. Click the Main Menu button to bring up the first-level menu. Then mouse over any menu item containing an arrow to bring up the next-level menu, and so on. You can go through a menu hierarchy and make selections from the final menu.

In addition to the Main Menu on the bottom panel, in Cinnamon that bottom panel can make almost anything you want to do possible. Among the choices here:

- ◆ **Show Desktop:** Hide (but do not close) all windows and display the desktop.
- ◆ **Firefox Web Browser:** Quickly access the web.
- ◆ **Terminal:** Open a terminal window.
- ◆ **Files:** Display your files.
- ◆ **Open Windows:** Jump back and forth between any open windows.
- ◆ **Active Icons:** for ejecting drives, adjusting volume, viewing battery life, and so on.

Looking at MATE

The last GNOME variant to explore is MATE. Like Cinnamon, this desktop is often associated with Linux Mint — and the two look very much alike. Figure 1-10 shows an example of MATE in Linux Mint.

Figure 1-10:
The MATE
desktop
looks
like both
Cinnamon
and
Windows.

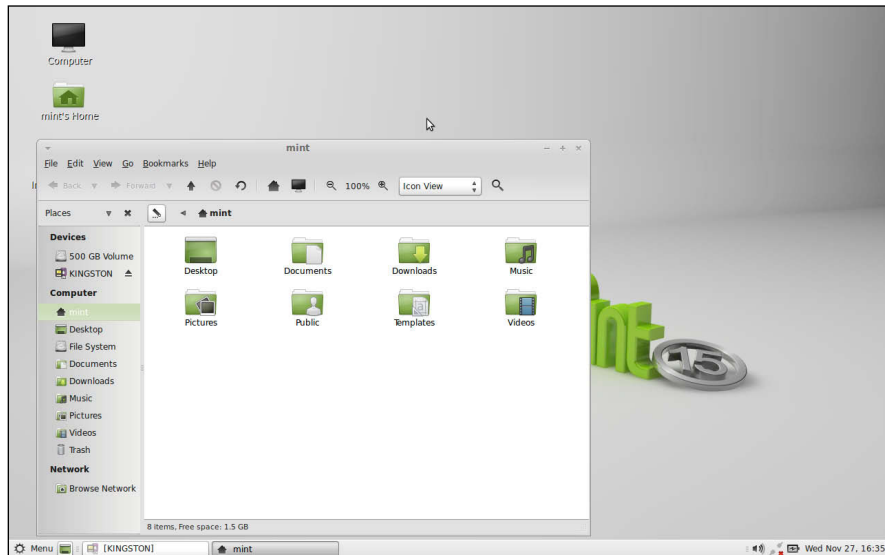

As in life, so in Linux: Which desktop you choose to use is as much a matter of preference as which car you drive, which cologne you wear, or which outfit you buy. It's important to what you're comfortable with and try to interface with it as best you can.

In Chapter 2 of this minibook, we move away from GNOME altogether and look at its prime competitor: KDE.

Chapter 2: The KDE Desktop

In This Chapter

- ✓ **Discovering KDE's common features**
- ✓ **Introducing the Main Menu**
- ✓ **Configuring the panel and the desktop**

As mentioned in Chapter 1 of this minibook, Linux distributions come with one (or both) of two popular graphical user interfaces (GUIs) — GNOME (or one or more of its variants) and KDE. With both interfaces installed, you can switch between the two in a matter of seconds. If you don't like GNOME, you can use KDE; or if you don't like KDE, you can use GNOME.

This chapter explores the major features of KDE, just as Chapter 1 of this minibook examines GNOME. I strongly encourage you to try both GUIs before you decide which one you're most comfortable using. Remember, you can run KDE applications under GNOME and vice versa. Several installation procedures, including those for Fedora and openSUSE, allow you to choose to install KDE or GNOME. Installing only one interface by default allows for a quicker and easier setup and installation; you can always go back and install the other interface later.



Each distribution customizes the desktop, so there may be subtle, minor differences between what you see in your distribution and what's described here.

Getting to Know the KDE Desktop

The initial desktop for KDE looks like any other popular GUI, such as Microsoft Windows desktop or the Mac OS X desktop. Figure 2-1 shows a typical KDE desktop.



KDE stands for the *K Desktop Environment*. The KDE project started in October 1996 with the intent to develop a common GUI for Unix systems that use the X Window System. The first beta version of KDE was released a year later, in October 1997. KDE version 1.0 was released in July 1998.



Figure 2-1:
A clean KDE
desktop.

Figure 2-1 is from openSUSE 12, which strives for a minimum of desktop icons. Along the bottom of the desktop is the *panel* — which is similar to the top and bottom bars in the Windows taskbar. The panel has buttons on the left (shortcuts to various programs), a set of buttons to the available desktops, a task area, a time display, and (to the right) icons that provide volume control and access to the KDE’s Clipboard manager, Klipper. In the middle part of the panel are buttons for any applications that you started (or that were automatically started for you).

Desktop context menus

The KDE desktop displays a context menu when you right-click a clear area on the desktop. The context menu offers a menu that includes the following options (with slight variations between distributions):

- ◆ Run Command
- ◆ Lock Screen
- ◆ Leave (exit the desktop)
- ◆ Desktop Settings (set such onscreen features as the wallpaper)

Figure 2-2 shows the desktop context menu in a typical KDE desktop.



Figure 2-2:
The context
menu in
KDE.

Icon context menus

Right-clicking any icon in KDE displays another menu, as shown in Figure 2-3. Many items on this context menu are the same no matter what icon you click, but right-clicking certain icons (for example, the CD-ROM device icon) produces a somewhat different menu. Desktop menu options with a right-pointing arrow have other menus that appear when you put the mouse pointer over the arrow. You can perform the following typical tasks from icon context menus:

- ◆ Open a folder in a file manager
- ◆ Open a file with an application that you choose
- ◆ Cut or copy
- ◆ Rename the icon
- ◆ Move the icon to the trash
- ◆ View the properties of that icon

For the CD-ROM device icon and similar devices, the icon context menu typically provides an option to eject the media.



No matter where you are in a GUI desktop, *always right-click before you pick*. You're bound to find something useful when you right-click!

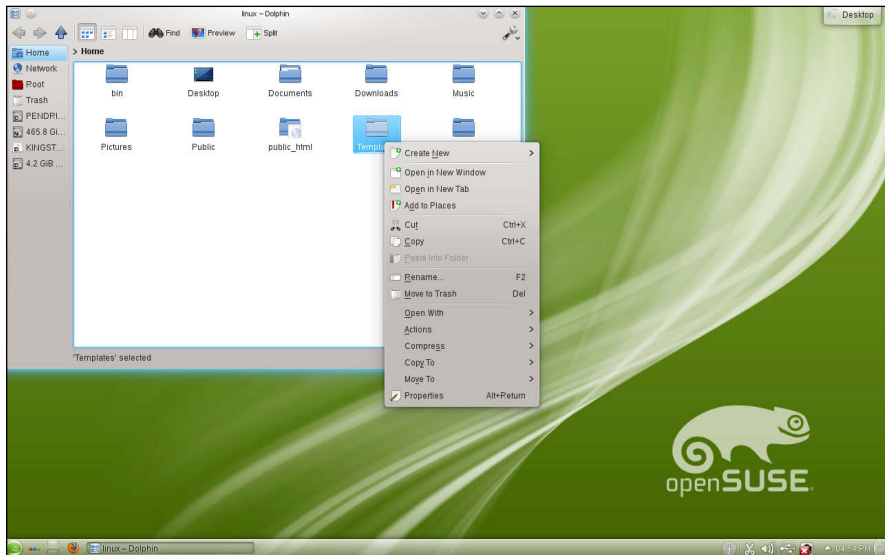

Figure 2-3:
The pop-up menu for an icon in KDE.

Understanding the KDE Panel

The *panel* is the long bar that stretches across the bottom of the desktop. Figure 2-4 shows a typical view of the KDE panel.

Figure 2-4:
The KDE panel.



The panel is a parking place for icons. Some icons start programs when you click them. Some show status (for example, what programs are currently running) as well as information such as the date and time.

If you move the mouse pointer on top of an icon, a Help balloon pops up and gives you a helpful hint about the icon.

The Main Menu button

The leftmost icon on the KDE panel is the *Main Menu* button. (KDE documentation calls the Main Menu button the *Application Starter*). Like the Start button in Microsoft Windows, the Main Menu button is where you typically find all your applications, organized into submenus. The Main Menu button is often labeled K, although the letter can be changed by the distribution.

Click the Main Menu button to see the first-level menu. Then mouse over any menu item with an arrow to bring up the next-level menu and so on. You can go through a menu hierarchy and make selections from the final menu. Figure 2-5 shows the Main Menu hierarchy in a typical KDE desktop.



Figure 2-5:
The KDE
menu
hierarchy.

The most recent versions of KDE feature the KickOff application launcher as their main menu. KickOff allows you to access frequently used applications more quickly than navigating through the traditional menu hierarchy. In most desktops, clicking the Main Menu button to open KickOff presents the following top-level categories:

- ◆ **Favorites:** Easy access to frequently used applications and documents. To quickly add a file to your Favorites, right-click it and choose Add to Favorites.
- ◆ **Applications:** The applications and tools installed on your system. Click a subcategory with a right-pointing arrow to open more options.
- ◆ **Computer:** Access to hard drives and removable memory devices, as well as the trash.
- ◆ **Recently Used:** A chronological display of recently opened documents and applications.
- ◆ **Leave:** Options to log out, restart, shut down the computer, and more.

In the Applications tab, you will find the following menu subcategories (and probably a few more depending on which distribution you are using):

- ◆ **Games:** A menu of games (and a lot of them at that) such as arcade games, board games, and card games.
- ◆ **Graphics:** Programs such as Flickr, KolourPaint, and KSnapshot (used to take the screenshots in this chapter).
- ◆ **Internet:** Internet applications, such as a web browser, an e-mail reader, and an instant messenger.
- ◆ **Multimedia:** Multimedia applications such as a CD player, a sound mixer, a sound recorder, and volume control.
- ◆ **Office:** Office applications such as the LibreOffice.org Office suite (includes the Writer word processor, the Calc spreadsheet, the Impress slide presentation program, and the Draw drawing program).
- ◆ **System:** The utilities needed for system configuration. An example of the System menu is shown in Figure 2-6.
- ◆ **Utilities:** Additional miscellaneous utilities that can be utilized by KDE, including text-to-speech tools, a personal alarm scheduler, and a screen magnifier.



Figure 2-6:
The System
menu
choices.



Three additional KDE menu choices — Administration, Settings, and System — may be present and will help you configure almost anything you need. They're not present in openSUSE because it uses YaST as the interface to accomplish those tasks.

In each distribution, the main menu and KickOff have different categories but the same menu organization, so you should usually be able to find what you need.

Panel icons

In addition to the Main Menu button, the KDE panel has several icons (labeled in Figure 2-4). You can identify any icon by moving your cursor over it and reading the pop-up description that appears. The most common icons are as follows:

- ◆ **Desktop Pager:** Navigate between workspaces or “virtual desktops.”
- ◆ **Open windows:** Display all currently open windows.
- ◆ **Active window:** Switch to another running application or window.
- ◆ **Network connection:** Display information about current wired or wireless connections.
- ◆ **Volume:** Display a volume control bar that you can use to change the sound's volume by dragging a slider.
- ◆ **Notifications and Jobs:** Mouse over to see the progress of current jobs such as file transfers or printing documents.
- ◆ **Time:** Display the time; clicking displays a calendar that shows the current date.
- ◆ **Panel toolbox:** Adjust size, location, and controls for the panel.

Configuring the KDE Bottom Panel

For all the power inherent in the KDE panel, it also has a great deal of flexibility. If you right-click a blank spot on the panel, the menu shown in Figure 2-7 appears. You use this menu to add and remove items from the panel and even create an additional panel (which allows you to configure your desktop to look and work as much like GNOME as you want it to).

The most powerful menu choice is Panel Options. Choosing Panel Options⇨ Panel Settings⇨More Settings displays the utility shown in Figure 2-8. From here, you can place the panel in a location other than its default location along the bottom, adjust the alignment of the panel, automatically hide the panel, select whether windows will appear in front of or behind the panel, and more.

Figure 2-7:
You have a lot of flexibility when configuring the panel.



Figure 2-8:
Configuring the KDE panel is easy.



Configuring the KDE Desktop

After right-clicking an empty spot on the desktop, you can choose Desktop Settings from the pop-up menu. Doing so displays the configuration tool shown in Figure 2-9. You can configure such items as the background and special mouse controls to perform helpful functions on the desktop.

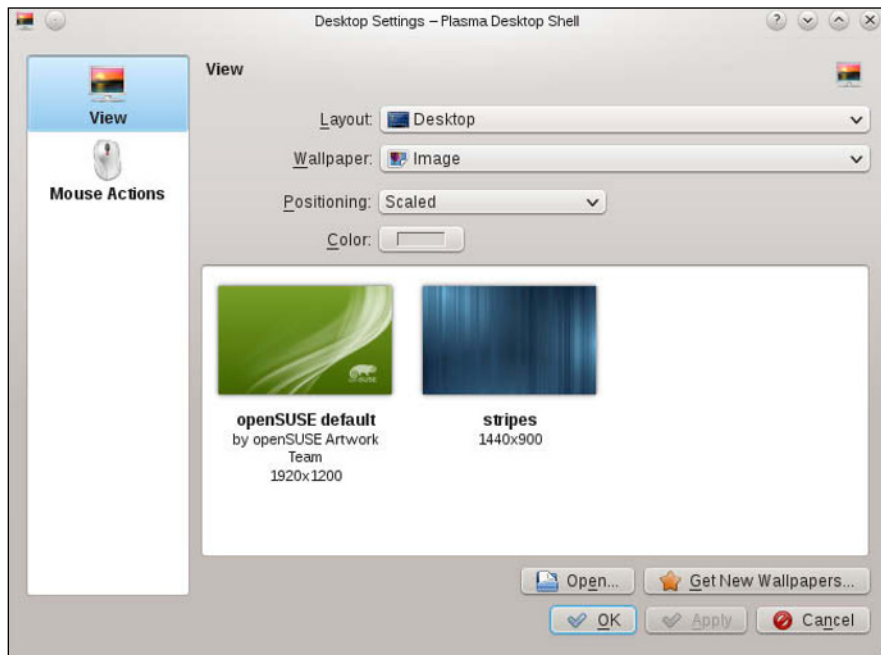

Figure 2-9: You can change the desktop settings.

For more thorough desktop configurations, choose Configure Desktop from the Main Menu to display the configuration options shown in Figure 2-10. You can set the screen size, adjust settings for multiple desktops, change the screen saver, and play around with desktop effects.

The settings here are organized into categories, such as Common Appearance and Behavior, and Workspace Appearance and Behavior, as well as Network Connectivity, and Hardware. Click an item to view the subcategories for that item. Click one of the subcategory items to change it. After making any changes you want, click the Apply button to enact the change. If you don't like the result, you can often click Reset to go back to the original setting.

Depending upon your distribution, you may also want to use downloadable programs such as SAX2 for desktop configuration. SAX2 is an open source program that simplifies configuration.

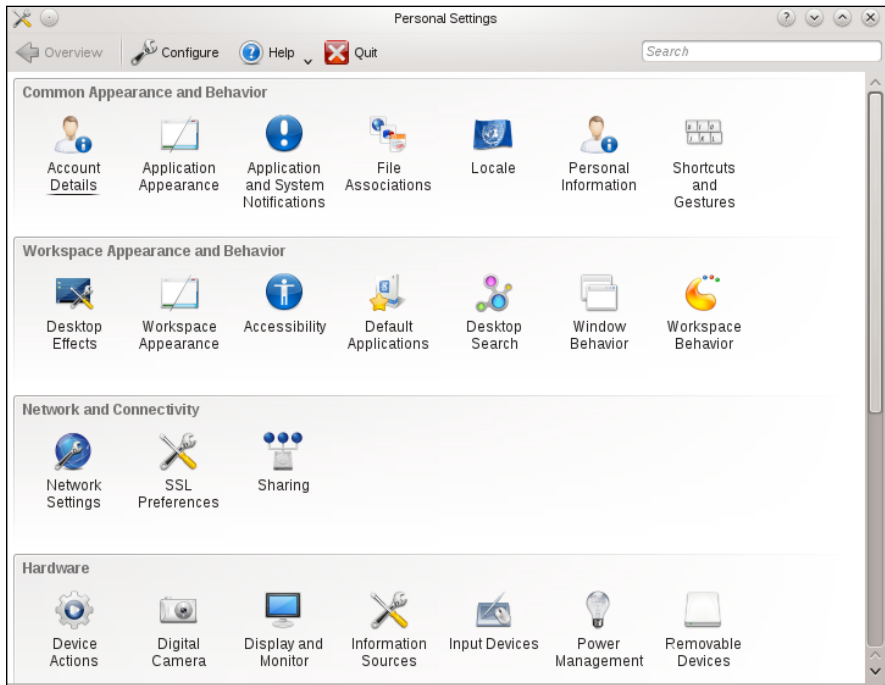

Figure 2-10: More desktop configuration options.

Chapter 3: Commanding the Shell

In This Chapter

- ✓ Opening a terminal window or a virtual console
- ✓ Discovering the bash shell
- ✓ Using Linux commands
- ✓ Writing a shell script

Sometimes things just don't work. What do you do if the GUI desktop stops responding to your mouse clicks? What if the GUI doesn't start at all? You can still tell your Linux system what to do, but you have to do it by typing commands into a text screen. In these situations, you work with the shell — the Linux command interpreter. This chapter introduces the `bash` shell, the default shell in most Linux distributions.

After you figure out how to work with the shell, you may even begin to like the simplicity and power of the Linux commands. And then, even if you're a GUI aficionado, someday soon you may find yourself firing up a terminal window and making the system sing and dance with two- or three-letter commands strung together by strange punctuation characters. (Hey, I can dream, can't I?)

Opening Terminal Windows and Virtual Consoles

First things first. If you're working in a GUI desktop, such as GNOME or KDE, where do you type commands for the shell? Good question.

The easiest way to get to the shell is to open a *terminal* (also called *console*) window. The GNOME and KDE GUIs in most distributions include an icon (or a Main Menu option) to open a terminal window. Click that icon or choose the menu option to get a terminal window. If you don't see such an icon in GNOME, choose Applications⇨Accessories⇨Terminal. Now you can type commands to your heart's content.

If, for some reason, the GUI seems to be *hung* (you click and type but nothing happens), you can turn to the *virtual consoles*. (The *physical console* is the monitor-and-keyboard combination.) The idea of virtual consoles is to give you the ability to switch among several text consoles even though you have only one physical console. Whether you're running a GUI or not, you can then use different text consoles to type different commands.

To get to the first virtual console from the GNOME or KDE desktop, press Ctrl+Alt+F1. Press Ctrl+Alt+F2 for the second virtual console, and so on. Each of these virtual consoles is a text screen where you can log in and type Linux commands to perform various tasks. When you're finished, type **exit** to log out.



You can use up to six virtual consoles. In most distributions, the seventh one is used for the GUI desktop. To get back to the GUI desktop, press Ctrl+Alt+F7.

Using the bash Shell

If you've used MS-DOS, you may be familiar with `COMMAND.COM`, the DOS command interpreter. That program displays the infamous `C:\>` prompt. In Windows, you can see this prompt if you open a command window. (To open a command window in Microsoft Windows, choose Start→Run, type **command** in the text box, and then click OK.)

Linux comes with a command interpreter that resembles `COMMAND.COM` in DOS, but it can do a whole lot more. The Linux command interpreter is called a *shell*.

The default shell in many Linux distributions is `bash`. When you open a terminal window or log in at a text console, the `bash` shell is what prompts you for commands. Then, when you type a command, the shell executes your command.



Just as there are multiple GUIs (GNOME or KDE) for Linux, you have a choice of shells besides `bash`. For example, some people prefer the `C` shell. You can easily change your default shell by using the `chsh` command.

In addition to the standard Linux commands, `bash` can execute any computer program. So you can type the name of an application (the name is usually more cryptic than what you see in GNOME or KDE menus) at the shell prompt, and the shell starts that application.

Understanding the syntax of shell commands

Because a shell interprets what you type, knowing how the shell processes the text you enter is important. All shell commands have the following general format. (Some commands have no options.)

```
command [option1] [option2] . . . [optionN]
```

Issuing such a command is a process commonly referred to as a *command line*. On a command line, you enter a command, followed by zero or more options (or *arguments*). These strings of options — the *command-line options* (or command-line arguments) — modify the way the command works so that you can get it to do specific tasks.

The shell uses a blank space or a tab to distinguish between the command and options. This means you must use a space or a tab to separate the command from the options and the options from one another.

If an option contains spaces, you put that option inside quotation marks. For example, to search for my name in the password file, I enter the following `grep` command (`grep` is used for searching for text in files):

```
grep "Emmett Dulaney" /etc/passwd
```

When `grep` prints the line with my name, it looks like this:

```
edulaney:x:1000:100:Emmett Dulaney:/home/edulaney:/bin/bash
```

If you create a user account with your username, type the `grep` command with your username as an argument to look for that username in the `/etc/passwd` file.



In the output from the `grep` command, you can see the name of the shell (`/bin/bash`) following the last colon (`:`). Because the `bash` shell is an executable file, it resides in the `/bin` directory; you must provide the full path to it.

The number of command-line options and their format depend on the actual command. Typically, these options look like `-X`, where `X` is a single character. For example, you can use the `-l` option with the `ls` command. The command lists the contents of a directory, and the option provides additional details. Here is a result of typing `ls -l` in a user's home directory:

```
total 0
drwxr-xr-x 2 edulaney users 48 2014-09-08 21:11 bin
drwx----- 2 edulaney users 320 2014-09-08 21:16 Desktop
drwx----- 2 edulaney users 80 2014-09-08 21:11 Documents
drwxr-xr-x 2 edulaney users 80 2014-09-08 21:11 public_html
drwxr-xr-x 2 edulaney users 464 2014-09-17 18:21 sdump
```

If a command is too long to fit on a single line, you can press the backslash key (`\`) followed by `Enter`. Then continue typing the command on the next line. For example, type the following command. (Press `Enter` after each line.)

```
cat \  
/etc/passwd
```

The `cat` command then displays the contents of the `/etc/passwd` file.

You can *concatenate* (that is, string together) several shorter commands on a single line by separating the commands by semicolons (`;`). For example, the following command

```
cd; ls -l; pwd
```

changes the current directory to your home directory, lists the contents of that directory, and then shows the name of that directory.

Combining shell commands

You can combine simple shell commands to create a more sophisticated command. For example, suppose that you want to find out whether a device file named `sbpcd` resides in your system's `/dev` directory because some documentation says you need that device file for your CD-ROM drive. You can use the `ls /dev` command to get a directory listing of the `/dev` directory and then browse through it to see whether that listing contains `sbpcd`.

Unfortunately, the `/dev` directory has a great many entries, so you may find it hard to find any item that has `sbpcd` in its name. You can, however, combine the `ls` command with `grep` and come up with a command line that does exactly what you want. Here's that command line:

```
ls /dev | grep sbpcd
```

The shell sends the output of the `ls` command (the directory listing) to the `grep` command, which searches for the string `sbpcd`. That vertical bar (`|`) is known as a *pipe* because it acts as a conduit (think of a water pipe) between the two programs — the output of the first command is fed into the input of the second one.

Controlling command input and output

Most Linux commands have a common feature — they always read from the *standard input* (usually, the keyboard) and write to the *standard output* (usually, the screen). Error messages are sent to the *standard error* (usually to the screen as well). These three devices often are referred to as `stdin`, `stdout`, and `stderr`.

You can make a command get its input from a file and then send its output to another file. Just so you know, the highfalutin term for this feature is *input and output redirection or I/O redirection*.

Table 3-1 shows the syntax of common I/O redirection commands, and the next few sections explain how to use some of these commands.

Table 3-1 Common Standard I/O Redirections

| <i>Task</i> | <i>Command Syntax</i> |
|---|---|
| Send <code>stdout</code> to a file | <code>command > file</code> |
| Send <code>stderr</code> to file | <code>command 2> file</code> |
| Send <code>stdout</code> and <code>stderr</code> to file | <code>command > file 2>&1</code> |
| Read <code>stdin</code> from a file | <code>command < file</code> |
| Read <code>stdin</code> from <code>file.in</code> and send <code>stdout</code> to <code>file.out</code> | <code>command < file.in > file.out</code> |
| Append <code>stdout</code> to the end of a file | <code>command >> file</code> |
| Append <code>stderr</code> to the end of a file | <code>command 2>> file</code> |
| Append <code>stdout</code> and <code>stderr</code> to the end of a file | <code>command >> file 2>&1</code> |
| Read <code>stdin</code> from the keyboard until the character <code>c</code> | <code>command <<c</code> |
| Pipe <code>stdout</code> to <code>command2</code> | <code>command command2</code> |
| Pipe <code>stdout</code> and <code>stderr</code> to <code>command2</code> | <code>command 2>&1 command2</code> |

Getting command input from a file

If you want a command to get its instructions by reading from a file, you can redirect the standard input to come from that file instead of from the keyboard. For example, type the following command:

```
sort < /etc/passwd
```

This command displays a sorted list of the lines in the `/etc/passwd` file. In this case, the less-than sign (`<`) redirects `stdin` so that the `sort` command reads its input from the `/etc/passwd` file.

Saving command output in a file

To save the output of a command in a file, redirect the standard output to a file. For example, type `cd` to change to your home directory, and then type the following command:

```
grep typedef /usr/include/* > typedef.out
```

This command searches through all files in the `/usr/include` directory for the occurrence of the text `typedef` — and then saves the output in a file called `typedef.out`. The greater-than sign (`>`) redirects `stdout` to a file. This

command also illustrates another feature of `bash`: When you use an asterisk (*), `bash` replaces the asterisk with a list of all filenames in the specified directory. Thus `/usr/include/*` means *all the files in the /usr/include directory*.



If you want to append a command's output to the end of an existing file instead of saving the output in a new file, use two greater-than signs (`>>`) like this:

```
command >> filename
```



Another interesting use of sending `stdout` to a file is the use of the `cat` command to quickly prepare small text files. For example, suppose that you want to create a new text file to store lines of text you type until you type **ZZ** and press Enter. Here is how you can accomplish that task:

```
cat <<ZZ > input.txt
```

After you type this command, you can keep typing lines and then type **ZZ** on a line when you are finished. Everything you type is saved in the file `input.txt`.

Saving error messages in a file

Sometimes you type a command, and it generates a lot of error messages that scroll by so fast you can't tell what's going on. One way to see all the error messages is to save them in a file so that you can see what the heck happened. You can do that by redirecting `stderr` to a file.

For example, type the following command:

```
find / -name COPYING -print 2> finderr
```

This command looks through the file system for files named `COPYING` and saves all the error messages (if there are any) in the `finderr` file. The number 2 followed by the greater-than sign (`2>`) redirects `stderr` to a file.



If you want to simply discard the error messages instead of saving them in a file, use `/dev/null` as the filename, like this:

```
find / -name COPYING -print 2> /dev/null
```



That `/dev/null` is a special file — often called the *bit bucket* and sometimes glorified as the *Great Bit Bucket in the Sky* — that simply discards whatever it receives. So now you know what they mean when you hear phrases, such as “Your mail probably ended up in the bit bucket.”

Typing less with automatic command completion

Many commands take a filename as an argument. To view the contents of the `/etc/modprobe.conf` text file, for example, type the following command:

```
cat /etc/modprobe.conf
```

The `cat` command displays the `/etc/modprobe.conf` file. For any command that takes a filename as an argument, you can use a `bash` feature to avoid having to type the entire filename. All you have to type is enough characters to uniquely identify the file in its directory.

To see an example, type `cat /etc/mod` but don't press Enter; press Tab instead. `bash` automatically completes the filename, so the command becomes `cat /etc/modprobe.conf`. Now press Enter to run the command.



Whenever you type a filename, press Tab after the first few characters of the filename. `bash` probably can complete the filename so that you don't have to type the entire name. If you don't enter enough characters to uniquely identify the file, `bash` beeps. Just type a few more characters and press Tab again.

Going wild with asterisks and question marks

You can avoid typing long filenames another way. (After all, making less work for users is why we use computers, isn't it?)

This particular trick involves using the asterisk (*) and question mark (?). These special characters are *wildcards* because they match zero or more characters in a line of text.

If you know MS-DOS, you may have used commands such as `COPY *.* A:` to copy all files from the current directory to the A: drive. `bash` accepts similar wildcards in filenames. As you expect, `bash` provides many more wildcard options than the MS-DOS command interpreter does. Of course, newer computers (particularly notebook computers and especially netbooks) don't have A and B drives anymore. That deprives an entire generation of the fun of trying to copy a large file onto floppy disks!

You can use three types of wildcards in `bash`:

- ◆ **Asterisk (*):** Matches zero or more characters in a filename. That means * denotes all files in a directory.
- ◆ **Question mark (?):** Matches any single character. If you type `test?`, that matches any five-character text that begins with `test`.
- ◆ **Set of characters in brackets:** Matches any single character from that set. The string `[aB]`, for example, matches only files named `a` or `B`. The string `[aB]*`, though, matches any filename that starts with `a` or `B`.

Wildcards are handy when you want to do something to many files. For example, to copy all the files from the `/media/cdrom` directory to the current directory, type the following:

```
cp /media/cdrom/* .
```

`bash` replaces the wildcard character `*` with the names of all the files in the `/media/cdrom` directory. The period at the end of the command represents the current directory.

You can use the asterisk with other parts of a filename to select a more specific group of files. Suppose you want to use the `grep` command to search for the text `typedef struct` in all files of the `/usr/include` directory that meet the following criteria:

- ◆ The filename starts with `s`
- ◆ The filename ends with `.h`

The wildcard specification `s*.h` denotes all filenames that meet these criteria. Thus you can perform the search with the following command:

```
grep "typedef struct" /usr/include/s*.h
```

The string contains a space that you want the `grep` command to find, so you have to enclose that string in quotation marks. That way, `bash` doesn't try to interpret each word in that text as a separate command-line argument.

The question mark (`?`) matches a single character. Suppose you have four files — `image1.pcx`, `image2.pcx`, `image3.pcx`, and `image4.pcx` — in the current directory. To copy these files to the `/media/floppy` directory, use the following command:

```
cp image?.pcx /media/floppy
```

`bash` replaces the single question mark with any single character and copies the four files to `/media`.

The third wildcard format — `[. . .]` — matches a single character from a specific set of characters enclosed in square brackets. You may want to combine this format with other wildcards to narrow the matching filenames to a smaller set. To see a list of all filenames in the `/etc/X11/xdm` directory that start with `x` or `X`, type the following command:

```
ls /etc/X11/xdm/[xX]*
```

Repeating previously typed commands

To make repeating long commands easy for you, `bash` stores up to 500 old commands as part of a *command history* (basically just a list of old commands). To see the command history, type **history**. `bash` displays a numbered list of the old commands, including those that you entered during previous logins.

If the command list is too long, you can limit the number of old commands that you want to see. For example, to see only the 10 most recent commands, type this command:

```
history 10
```

To repeat a command from the list that the `history` command shows, simply type an exclamation point (!), followed by that command's number. To repeat command number 3, type **!3**.

You can repeat a command without knowing its command number. Suppose you typed `more /usr/lib/X11/xdm/xdm-config` a few minutes ago and now you want to look at that file again. To repeat the previous `more` command, type the following:

```
!more
```

Often you may want to repeat the last command that you just typed, perhaps with a slight change. For example, you may have displayed the contents of the directory by using the `ls -l` command. To repeat that command, type two exclamation points as follows:

```
!!
```

Sometimes you may want to repeat the previous command but add extra arguments to it. Suppose that `ls -l` shows too many files. Simply repeat that command but pipe the output through the `more` command as follows:

```
!! | more
```

`bash` replaces the two exclamation points with the previous command and then appends `| more` to that command.



Here's the easiest way to recall previous commands: Just press the up-arrow key, and `bash` keeps going backward through the history of commands you previously typed. To move forward in the command history, press the down-arrow key.

Discovering and Using Linux Commands

You type Linux commands at the shell prompt. By *Linux commands*, I mean some of the commands that the `bash` shell understands as well as the command-line utilities that come with Linux. In this section, I introduce you to a few major categories of Linux commands.

I can't cover every single Linux command in this chapter, but I want to give you a feel for the breadth of the commands by showing you common Linux commands. Table 3-2 lists common Linux commands by category. Before you start memorizing any Linux commands, browse this table.

| Table 3-2 Essential Linux Commands | |
|---|--|
| <i>Command Name</i> | <i>Action</i> |
| Help and Abbreviations | |
| <code>apropos</code> | Find online manual pages for a specified keyword. |
| <code>info</code> | Display online help information about a specified command. |
| <code>man</code> | Display online help information. |
| <code>whatis</code> | Search for complete words only and find the online manual pages. |
| <code>alias</code> | Define an abbreviation for a long command. |
| <code>type</code> | Show the type and location of a command. |
| <code>unalias</code> | Delete an abbreviation defined using <code>alias</code> . |
| Managing Files and Directories | |
| <code>cd</code> | Change the current directory. |
| <code>chmod</code> | Change file permissions. |
| <code>chown</code> | Change the file owner and group. |
| <code>cp</code> | Copy files. |
| <code>ln</code> | Create symbolic links to files and directories. |
| <code>ls</code> | Display the contents of a directory. |
| <code>mkdir</code> | Create a directory. |
| <code>mv</code> | Rename a file and move the file from one directory to another. |
| <code>rm</code> | Delete files. |
| <code>rmdir</code> | Delete directories. |
| <code>pwd</code> | Display the current directory. |
| <code>touch</code> | Update a file's timestamp. |

| <i>Command Name</i> | <i>Action</i> |
|-------------------------|--|
| Finding Files | |
| find | Find files based on specified criteria, such as name and size. |
| locate | Find files using a periodically updated filename database. (The database is created by the <code>updatedb</code> program.) |
| whereis | Find files based in the typical directories where <i>executable</i> (also known as <i>binary</i>) files are located. |
| which | Find files in the directories listed in the PATH environment variable. |
| Processing Files | |
| cat | Display a file on standard output (can be used to concatenate several files into one big file). |
| cut | Extract specified sections from each line of text in a file. |
| dd | Copy blocks of data from one file to another (used to copy data from devices). |
| diff | Compare two text files and find any differences. |
| expand | Convert all tabs to spaces. |
| file | Display the type of data in a file. |
| fold | Wrap each line of text to fit a specified width. |
| grep | Search for regular expressions in a text file. |
| less | Display a text file one page at a time (go backward by pressing b). |
| lpr | Print files. |
| more | Display a text file, one page at a time (goes forward only). |
| nl | Number all nonblank lines in a text file and print the lines to standard output. |
| paste | Concatenate corresponding lines from several files. |
| patch | Update a text file using the differences between the original and revised copy of the file. |
| sed | Copy a file to standard output while applying specified editing commands. |
| sort | Sort lines in a text file. |
| split | Break up a file into several smaller files with specified size. |
| tac | Reverse a file (last line first and so on). |
| tail | Display the last few lines of a file. |
| tr | Substitute one group of characters for another throughout a file. |
| uniq | Eliminate duplicate lines from a text file. |

(continued)

Table 3-2 (continued)

| <i>Command Name</i> | <i>Action</i> |
|--|---|
| <code>wc</code> | Count the number of lines, words, and characters in a text file. |
| <code>zcat</code> | Display a compressed file (after decompressing). |
| <code>zless</code> | Display a compressed file one page at a time (go backward by pressing b). |
| <code>zmore</code> | Display a compressed file one page at a time. |
| Archiving and Compressing Files | |
| <code>compress</code> | Compress files. |
| <code>cpio</code> | Copy files to and from an archive. |
| <code>gunzip</code> | Decompress files compressed with GNU Zip (<code>gzip</code>). |
| <code>gzip</code> | Compress files using GNU Zip. |
| <code>tar</code> | Create an archive of files in one or more directories (originally meant for archiving on tape). |
| <code>uncompress</code> | Decompress files compressed with <code>compress</code> . |
| Managing Files | |
| <code>bg</code> | Run an interrupted process in the background. |
| <code>fg</code> | Run a process in the foreground. |
| <code>free</code> | Display the amount of free and used memory in the system. |
| <code>halt</code> | Shut down Linux and halt the computer. |
| <code>kill</code> | Send a signal to a process (usually used to terminate a process). |
| <code>ldd</code> | Display the shared libraries needed to run a program. |
| <code>nice</code> | Run a process with a lower priority (referred to as nice mode). |
| <code>ps</code> | Display a list of currently running processes. |
| <code>printenv</code> | Display the current environment variables. |
| <code>pstree</code> | Show parent-child process relationships. |
| <code>reboot</code> | Stop Linux and then restart the computer. |
| <code>shutdown</code> | Shut down Linux. |
| <code>top</code> | Display a list of most processor- and memory-intensive processes. |
| <code>uname</code> | Display information about the system and the Linux kernel. |
| Managing Users | |
| <code>chsh</code> | Change the shell (command interpreter). |
| <code>groups</code> | Print the list of groups that include a specified user. |

| <i>Command Name</i> | <i>Action</i> |
|---------------------------------|---|
| id | Display the user and group ID for a specified username. |
| passwd | Change the password. |
| su | Start a new shell as another user (the other user is assumed to be <code>root</code> when the command is invoked without any argument). |
| Managing the File System | |
| df | Summarize free and available space in all mounted storage devices. |
| du | Display disk usage information. |
| fdformat | Format a floppy disk. |
| fdisk | Partition a hard drive. |
| fsck | Check and repair a file system. |
| mkfs | Create a new file system. |
| mknod | Create a device file. |
| mkswap | Create a swap space for Linux in a file or a hard drive partition. |
| mount | Mount a device (for example, the CD-ROM) on a directory in the file system. |
| swapoff | Deactivate a swap space. |
| swapon | Activate a swap space. |
| sync | Write <i>buffered</i> (saved in memory) data to files. |
| tty | Display the device name for the current terminal. |
| umount | Unmount a device from the file system. |
| Dates and Times | |
| cal | Display a calendar for a specified month or year. |
| date | Display the current date and time or set a new date and time. |

Becoming root (superuser)

When you want to do anything that requires a high privilege level (for example, administering your system), you have to become `root`. Normally, you log in as a regular user with your everyday username. When you need the privileges of the superuser, though, use the following command to become `root`:

```
su -
```

That's `su` followed by a space and the minus sign (or hyphen). The shell then prompts you for the `root` password. Type the password and press Enter.

After you've finished with whatever you want to do as `root` (and you have the privilege to do anything as `root`), type **exit** to return to your normal username.



Instead of becoming `root` by using the `su -` command, you can also type **sudo** followed by the command that you want to run as `root`. In Ubuntu, you must use the `sudo` command because you don't get to set up a `root` user when you install Ubuntu. If you're listed as an authorized user in the `/etc/sudoers` file, `sudo` executes the command as if you were logged in as `root`. Type **man sudoers** to read more about the `/etc/sudoers` file.

Managing processes

Every time the shell executes a command that you type, it starts a process. The shell itself is a process, as are any scripts or programs that the shell runs.

Use the `ps ax` command to see a list of processes. When you type **ps ax**, `bash` shows you the current set of processes. Here are a few lines of output when I type **ps ax -cols 132**. (I included the `-cols 132` option to ensure that you can see each command in its entirety.)

```
PID TTY STAT TIME COMMAND
1 ? S 0:01 init [5]
2 ? SN 0:00 [ksoftirqd/0]
3 ? S< 0:00 [events/0]
4 ? S< 0:00 [khelper]
9 ? S< 0:00 [kthread]
19 ? S< 0:00 [kacpid]
75 ? S< 0:00 [kblockd/0]
115 ? S 0:00 [pdflush]
116 ? S 0:01 [pdflush]
118 ? S< 0:00 [aio/0]
117 ? S 0:00 [kswapd0]
711 ? S 0:00 [kseriod]
1075 ? S< 0:00 [reiserfs/0]
2086 ? S 0:00 [kjournald]
2239 ? S<s 0:00 /sbin/udev -d
. . . lines deleted . . .
6374 ? S 1:51 /usr/X11R6/bin/X :0 -audit 0 -auth /var/lib/gdm/:0.Xauth
-nolisten tcp vt7
6460 ? Ss 0:02 /opt/gnome/bin/gdmgreeter
6671 ? Ss 0:00 sshd: edulaney [priv]
6675 ? S 0:00 sshd: edulaney@pts/0
6676 pts/0 Ss 0:00 -bash
6712 pts/0 S 0:00 vsftpd
14702 ? S 0:00 pickup -l -t fifo -u
14752 pts/0 R+ 0:00 ps ax --cols 132
```



In this listing, the first column has the heading `PID` and shows a number for each process. `PID` stands for *process ID* (identification), which is a sequential number assigned by the Linux kernel. If you look through the output of the `ps ax` command, you see that the `init` command is the first process and has a `PID` of 1. That's why `init` is referred to as the *mother of all processes*.

The `COMMAND` column shows the command that created each process, and the `TIME` column shows the cumulative CPU time used by the process. The `STAT` column shows the state of a process — `S` means the process is sleeping, and `R` means it's running. The symbols following the status letter have further meanings; for example `<` indicates a high-priority process, and `+` means that the process is running in the foreground. The `TTY` column shows the terminal, if any, associated with the process.



The process ID, or process number, is useful when you have to forcibly stop an errant process. Look at the output of the `ps ax` command and note the PID of the offending process. Then, use the `kill` command with that process number to stop the process. For example, to stop process number 8550, start by typing the following command:

```
kill 8550
```

If the process doesn't stop after five seconds, repeat the command. The next step in stopping a stubborn process is to type `kill -INT pid`, where `pid` is the process number. If that doesn't work, try the following command as a last resort:

```
kill -9 8550
```



The `-9` option means send signal number 9 to the process. Signal number 9 is the `KILL` signal, which should cause the process to exit. You could also type this command as `kill -KILL pid`, where `pid` is the process ID.

Working with date and time

You can use the `date` command to display the current date and time or set a new date and time. Type `date` at the shell prompt and you get a result similar to the following:

```
Fri Mar 14 15:10:07 EST 2014
```

As you can see, issuing the `date` command alone displays the current date and time.

To set the date, log in as `root` and then type `date` followed by the date and time in the `MMDDhhmmYYYY` format, where each character is a digit. For example, to set the date and time to December 31, 2014 and 9:30 p.m., you type

```
date 123121302014
```

The `MMDDhhmmYYYY` date and time format is similar to the 24-hour military clock and has the following meaning:

- ◆ `MM` is a two-digit number for the month (01 through 12).
- ◆ `DD` is a two-digit number for the day of the month (01 through 31).

- ◆ hh is a two-digit hour in 24-hour format (00 is midnight and 23 is 11 p.m.).
- ◆ mm is a two-digit number for the minute (00 through 59).
- ◆ YYYY is the four-digit year (such as 2014).

The other interesting date-related command is `cal`. If you type `cal` without any options, it prints a calendar for the current month. If you type `cal` followed by a number, `cal` treats the number as the year and prints the calendar for that year. To view the calendar for a specific month in a specific year, provide the month number (1 = January, 2 = February, and so on) followed by the year. Thus, type `cal 6 2014` and you get the calendar for June 2014, as follows:

```
June 2014
Su Mo Tu We Th Fr Sa
 1  2  3  4  5  6  7
 8  9 10 11 12 13 14
15 16 17 18 19 20 21
22 23 24 25 26 27 28
29 30
```

Processing files

You can search through a text file with `grep` and view a text file, a screen at a time, with `more`. For example, to search for my username in the `/etc/passwd` file, I use

```
grep edulaney /etc/passwd
```

To view the `/etc/inittab` file a screen at a time, I type

```
more /etc/inittab
```

As each screen pauses, I press the spacebar to go to the next page.

Many more Linux commands work on files — mostly on text files, but some commands also work on any file. The sections that follow describe a few of the file-processing tools.

Counting words and lines in a text file

I am always curious about the size of files. For text files, the number of characters is basically the size of the file in bytes (because each character takes up a byte of storage space). What about words and the number of lines, though?

The Linux `wc` command comes to the rescue. The `wc` command displays the total number of lines, words, and characters in a text file. For example, type `wc /etc/inittab` and you see output similar to the following:

```
97 395 2926 /etc/inittab
```

In this case, `wc` reports that 97 lines, 395 words, and 2,926 characters are in the `/etc/inittab` file. If you simply want to see the number of lines in a file, use the `-l` option and type `wc -l /etc/inittab`. The resulting output should be similar to the following:

```
97 /etc/inittab
```

As you can see, with the `-l` option, `wc` simply displays the line count.

If you don't specify a filename, the `wc` command expects input from the standard input. You can use the pipe feature (`|`) of the shell to feed the output of another command to `wc`, which can be handy sometimes.



Suppose you want a rough count of the processes running on your system. You can get a list of all processes with the `ps ax` command, but instead of counting lines manually, just pipe the output of `ps` to `wc` and you get a rough count automatically:

```
ps ax | wc -l
86
```

Here the `ps` command produces 86 lines of output. Because the first line simply shows the headings for the tabular columns, you can estimate that about 85 processes are running on your system. (This count probably includes the processes used to run the `ps` and `wc` commands as well.)

Sorting text files

You can sort the lines in a text file by using the `sort` command. To see how the `sort` command works, first type `more /etc/passwd` to see the current contents of the `/etc/passwd` file. Now type `sort /etc/passwd` to see the lines sorted alphabetically. If you want to sort a file and save the sorted version in another file, you have to use the `bash` shell's output redirection feature, like this:

```
sort /etc/passwd > ~/sorted.text
```

This command sorts the lines in the `/etc/passwd` file and saves the output in a file named `sorted.text` in your home directory.

Substituting or deleting characters from a file

Another interesting command is `tr`, which substitutes one group of characters for another (or deletes a selected character) throughout a file. Suppose that you have to occasionally use MS-DOS text files on your Linux system. Although you may expect to use a text file on any system without any problems, you find one catch: DOS uses a carriage return followed by a line feed to mark the end of each line whereas Linux uses only a line feed.



On your Linux system, you can get rid of the extra carriage returns in the DOS text file by using the `tr` command with the `-d` option. Essentially, to convert the DOS text file named `filename.dos` to a Linux text file named `filename.linux`, type the following:

```
tr -d '\015' < filename.dos > filename.linux
```

In this command, `'\015'` denotes the code for the carriage-return character in octal notation.

Splitting a file into several smaller files

The `split` command is handy for those times when you want to copy a file but the file is too large to send as one e-mail attachment. You can then use the `split` command to break up the file into multiple smaller files.

By default, `split` puts 1,000 lines into each file. The new, `split` files are named by groups of letters such as `aa`, `ab`, `ac`, and so on. You can specify a prefix for the filenames. For example, to split a large file called `hugefile.tar` into smaller files, use `split` as follows:

```
split -b 1440k hugefile.tar part.
```

This command splits the `hugefile.tar` file into 1440K chunks. The command creates files named `part.aa`, `part.ab`, `part.ac`, and so on.

To combine the `split` files back into a single file, use the `cat` command as follows:

```
cat part.?? > hugefile.tar
```

In this case, the two question marks (`??`) match any two-character extension in the filename. In other words, the filename `part.??` matches all filenames such as `part.12`, `part.aa`, `part.ab`, and `part.2b`.

Writing Shell Scripts

If you've ever used MS-DOS, you may remember MS-DOS *batch files*, which are text files with MS-DOS commands. Similarly, *shell scripts* are also text files with a bunch of shell commands.

If you aren't a programmer, you may feel apprehensive about programming, but shell programming can be as simple as storing a few commands in a file. Right now, you might not be up to writing complex shell scripts, but you can certainly try out a simple shell script.

To try your hand at a little shell programming, type the following text at the shell prompt exactly as shown and then press Ctrl+D when you're finished:

```
cd
cat > simple
#!/bin/sh
echo "This script's name is: $0"
echo Argument 1: $1
echo Argument 2: $2
```

Press Ctrl+D. The `cd` command changes the current directory to your home directory. Then the `cat` command displays the next line and any other lines you type before pressing Ctrl+D. In this case, I use `> simple` to send the output to a file named `simple`. After you press Ctrl+D, the `cat` command ends, and you see the shell prompt again. You created a file named `simple` that contains the following shell script:

```
#!/bin/sh
echo "This script's name is: $0"
echo Argument 1: $1
echo Argument 2: $2
```

The first line causes Linux to run the `bash` shell program (of the name `/bin/bash`). The shell then reads the rest of the lines in the script.

Just as most Linux commands accept command-line options, a `bash` script also accepts command-line options. Inside the script, you can refer to the options as `$1`, `$2`, and so on. The special name `$0` refers to the name of the script itself.

To run this shell script, first you have to make the file executable (that is, turn it into a program) with the following command:

```
chmod +x simple
```

Now type **`./simple one two`** to run the script, and it displays the following output:

```
This script's name is: ./simple
Argument 1: one
Argument 2: two
```

The `./` prefix to the script's name indicates that the `simple` file is in the current directory.

This script simply prints the script's name and the first two command-line options that the user types after the script's name.

Next, try running the script with a few arguments, as follows:

```
./simple "This is one argument" second-argument third
This script's name is: ./simple
Argument 1: This is one argument
Argument 2: second-argument
```

The shell treats the entire string in the double quotation marks as a single argument. Otherwise, the shell uses spaces as separators between arguments on the command line.

Most useful shell scripts are more complicated than this simple script, but this easy exercise gives you a rough idea of how to write shell scripts.



Place Linux commands in a file and use the `chmod` command to make the file executable. Voilà! You created a shell script!

Chapter 4: Navigating the Linux File System

In This Chapter

- ✓ Finding out about the Linux file system
- ✓ Navigating the system with Linux commands
- ✓ Understanding file permissions
- ✓ Manipulating files and directories with Linux commands

To use files and directories well, you need to understand the concept of a hierarchical file system. Even if you use the GUI file managers (addressed in the next chapter) to access files and folders (folders are also called *directories*), you can benefit from a lay of the land of the file system.

This chapter introduces the Linux file system and shows you how to work with files and directories using several Linux commands.

Understanding the Linux File System

Like any other operating system, Linux organizes information in files and directories. A *directory* is a special file that can contain other files and directories. Because a directory can contain other directories, this method of organizing files gives rise to a hierarchical structure. This hierarchical organization of files is the *file system*.

The Linux file system gives you a unified view of all storage on your PC. The file system has a single `root` directory, indicated by a forward slash (`/`). Within the `root` directory is a hierarchy of files and directories. Parts of the file system can reside in different physical media, such as a hard drive, an external drive, and a CD-ROM. Figure 4-1 illustrates the concept of the Linux file system (which is the same in any Linux system) and how it spans multiple physical devices.

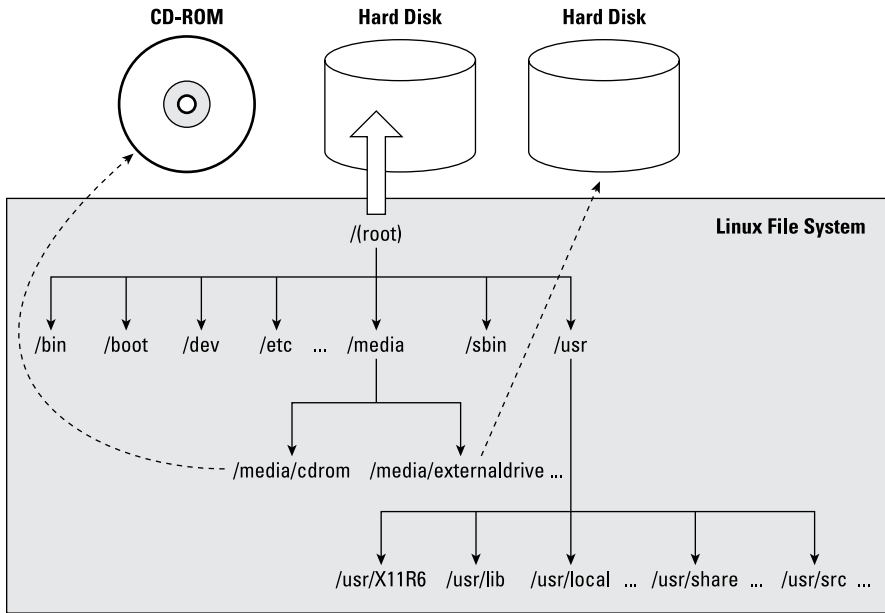

Figure 4-1: The Linux file system provides a unified view of storage that may span multiple storage devices.

If you're familiar with other operating systems such as Windows, you may find something missing in the Linux file system: You don't find drive letters in Linux. All disk drives and CD-ROM drives are part of a single file system.



In Linux, you can have long filenames (up to 256 characters), and filenames are case-sensitive. Often these filenames have multiple extensions, such as `sample.tar.z`. Unix filenames can take many forms, such as the following: `index.html`, `Makefile`, `binutils-2.15.92.0.2-5.i386.rpm`, `vsftpd_2.0.3-1_i386.deb`, `.bash_profile`, and `http_src.tar.gz`.

To locate a file, you need more than just the filename. You also need information about the directory hierarchy. The extended filename, showing the full hierarchy of directories leading to the file, is the *pathname*. As the name implies, it's the path to the file through the maze of the file system. Figure 4-2 shows a typical pathname for a file in Linux.

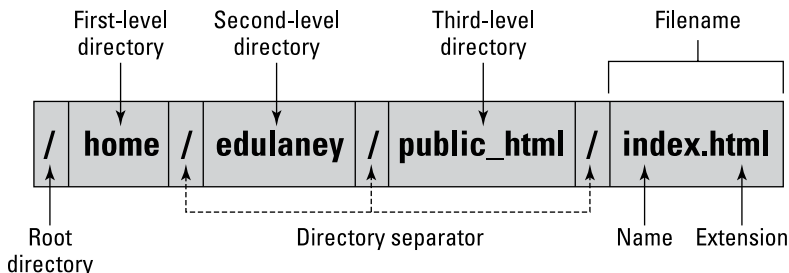

Figure 4-2: The path for the file shows the sequence of directories leading up to the file.

As Figure 4-2 shows, the pathname has the following parts:

- ◆ **The root directory**, indicated by a forward slash (/) character.
- ◆ **The directory hierarchy**, with each directory name separated from the previous one by a forward slash (/) character. A / appears after the last directory name.
- ◆ **The filename**, with a name and one or more optional extensions. (A period appears before each extension.)

The Linux file system has a well-defined set of top-level directories, and some of these directories have specific purposes. Finding your way around the file system is easier if you know the purpose of these directories. You also become adept at guessing where to look for specific types of files when you face a new situation. Table 4-1 briefly describes the top-level directories in the Linux file system.

| <i>Directory</i> | <i>Contains</i> |
|------------------|--|
| / | Base of the file system. All files and directories are contained logically in the <code>root</code> , or <code>/</code> , directory, regardless of their physical locations. |
| /bin | Executable programs that are part of the Linux operating system. Many Linux commands, such as <code>cat</code> , <code>cp</code> , <code>ls</code> , <code>more</code> , and <code>tar</code> , are located in <code>/bin</code> . |
| /boot | Linux kernel and other files that the LILO and GRUB boot managers need. (The kernel and other files can be anywhere, but placing them in the <code>/boot</code> directory is customary.) |
| /dev | Special files that represent devices attached to the system. |
| /etc | Most system configuration files and the initialization scripts (in the <code>/etc/rc.d</code> subdirectory). |
| /home | Home directories of all users. User <code>edulaney</code> 's home directory, for example, is <code>/home/edulaney</code> . |
| /lib | Library files for all programs stored in <code>/sbin</code> and <code>/bin</code> directories (including the loadable driver modules) needed to start Linux. |
| /lost+found | Lost files. Every disk partition has a <code>lost+found</code> directory. |

(continued)

Table 4-1 (continued)

| <i>Directory</i> | <i>Contains</i> |
|---------------------|---|
| <code>/media</code> | The <code>/media/cdrom</code> or <code>/media/cdrom0</code> directory is for mounting the CD/DVD-ROM drive. If you have a CD/DVD recorder, you find a <code>/media/cdrecorder</code> directory instead of <code>/media/cdrom</code> and may also find <code>/media/DVD</code> . Used for mounting file systems on removable media, such as CD/DVD-ROM drives, flash drives, external drives, floppy disks, and Zip drives. If you have a very old machine that still has a floppy drive on it, then the <code>/media/floppy</code> directory will also exist for mounting floppy disks. |
| <code>/mnt</code> | Temporarily mounted file systems. |
| <code>/opt</code> | Storage for large application software packages. For example, some distributions install the LibreOffice.org Office suite in the <code>/opt</code> directory. |
| <code>/proc</code> | Various information about the processes running in the Linux system. |
| <code>/root</code> | Home directory for the <code>root</code> user. |
| <code>/sbin</code> | Executable files representing commands typically used for system administration tasks and used by the <code>root</code> user. Commands such as <code>halt</code> and <code>shutdown</code> reside in the <code>/sbin</code> directory. |
| <code>/srv</code> | Data for services (such as web and FTP) offered by this system. |
| <code>/sys</code> | Information about the devices, as seen by the Linux kernel. |
| <code>/tmp</code> | Temporary directory that any user can use as a <i>scratch</i> directory, meaning that the contents of this directory are considered unimportant and usually are deleted every time the system boots. |
| <code>/usr</code> | Subdirectories for many important programs, such as the X Window System (in the <code>/usr/X11R6</code> directory) and the online manual. (Table 4-2 shows some of the standard subdirectories in <code>/usr</code> .) |
| <code>/var</code> | Various system files (such as logs), as well as directories for holding other information, such as files for the web server and anonymous FTP server. |

The `/usr` and `/var` directories also contain a number of standard subdirectories. Table 4-2 lists the important subdirectories in `/usr`. Table 4-3 shows a similar breakdown for the `/var` directory.

Table 4-2 Important /usr Subdirectories

| <i>Subdirectory</i> | <i>Description</i> |
|---------------------|---|
| /usr/bin | Executable files for many more Linux commands, including utility programs that are commonly available in Linux but aren't part of the core Linux operating system. |
| /usr/games | Some old Linux games. |
| /usr/include | Header files (filenames ending in .h) for the C and C++ programming languages and the X11 header files in the /usr/include/X11 directory and the Linux kernel header files in the /usr/include/linux directory. |
| /usr/lib | Libraries for C and C++ programming languages and many other libraries, such as database libraries and graphical toolkit libraries. |
| /usr/local | Local files. The /usr/local/bin directory, for example, is supposed to be the location for any executable program developed on your system. |
| /usr/sbin | Many administrative commands, such as commands for e-mail and networking. |
| /usr/share | Shared data, such as default configuration files and images for many applications. For example, /usr/share/gnome contains various shared files for the GNOME desktop, and /usr/share/doc has the documentation files for many Linux applications (such as the bash shell, the Sawfish window manager, and The GIMP image processing program). |
| /usr/share/man | Online manual (which you can read by using the man command). |
| /usr/src | Source code for the Linux kernel (the core operating system). |

Table 4-3 Important /var Subdirectories

| <i>Subdirectory</i> | <i>Contains</i> |
|---------------------|---|
| /var/cache | Storage area for cached data for applications. |
| /var/lib | Information relating to the current state of applications. |
| /var/lock | Locked files to ensure that a resource is used by one application only. |

(continued)

Table 4-3 (continued)

| <i>Subdirectory</i> | <i>Contains</i> |
|-------------------------|---|
| <code>/var/log</code> | Log files organized into subdirectories. The <code>syslogd</code> server stores its log files in <code>/var/log</code> , with the exact content of the files depending on the <code>syslogd</code> configuration file <code>/etc/syslog.conf</code> . For example, <code>/var/log/messages</code> is the main system log file; <code>/var/log/secure</code> contains log messages from secure services (such as <code>sshd</code> and <code>xinetd</code>); and <code>/var/log/maillog</code> contains the log of mail messages. |
| <code>/var/mail</code> | User mailbox files. |
| <code>/var/opt</code> | Variable data for packages stored in <code>/opt</code> directory. |
| <code>/var/run</code> | Data describing the system since the time it was booted. |
| <code>/var/spool</code> | Data that's waiting for some kind of processing. |
| <code>/var/tmp</code> | Temporary files preserved between system reboots. |
| <code>/var/yp</code> | Network Information Service (NIS) database files. |

Navigating the File System with Linux Commands

Although GUI file managers such as Nautilus (in GNOME) or Konqueror (in KDE) are easy to use, you can use them only if you have a working GUI desktop. Sometimes you may not have a graphical environment to run a graphical file manager. For example, you may be logged in through a text terminal, or X may not be working on your system. In those situations, you have to rely on Linux commands to work with files and directories. You can always use Linux commands, even in the graphical environment — all you have to do is open a terminal window and type the Linux commands.

In this section, I briefly describe some Linux commands for moving around the Linux file system.

Commands for directory navigation

In Linux, when you log in as `root`, your home directory is `/root`. For other users, the home directory is usually in the `/home` directory. My home directory (when I log in as `edulaney`) is `/home/edulaney`. This information is stored in the `/etc/passwd` file. By default, only you have permission to save files in your home directory, and only you can create subdirectories in your home directory to further organize your files.

Linux supports the concept of a *current* directory, which is the directory on which all file and directory commands operate. After you log in, for example, your current directory is the home directory. To see the current directory, type the `pwd` command.

To change the current directory, use the `cd` command. To change the current directory to `/usr/lib`, type the following:

```
cd /usr/lib
```

Then, to change the directory to the `cups` subdirectory in `/usr/lib`, type this command:

```
cd cups
```

Now, if you use the `pwd` command, that command shows `/usr/lib/cups` as the current directory.

These two examples show that you can refer to a directory's name in two ways:

- ◆ **Absolute pathname:** An example is `/usr/lib`, which is an exact directory in the directory tree. Think of the absolute pathname as the complete mailing address for a package that the postal service will deliver to your next-door neighbor.
- ◆ **Relative directory name:** An example is `cups`, which represents the `cups` subdirectory of the current directory, whatever that may be. Think of the relative directory name as giving the postal carrier directions from your house to the one next door so the carrier can deliver the package.

If I type `cd cups` in `/usr/lib`, the current directory changes to `/usr/lib/cups`. However, if I type the same command in `/home/edulaney`, the shell tries to change the current directory to `/home/edulaney/cups`.



Use the `cd` command without any arguments to change the current directory back to your home directory. No matter where you are, typing `cd` at the shell prompt brings you back home!



The tilde character (`~`) refers to your home directory. Thus you can change the current directory to your home directory by using the command `cd ~`. You can refer to another user's home directory by appending that user's name to the tilde. Thus `cd ~superman` changes the current directory to the home directory of `superman`.



Wait, there's more. A single dot (`.`) and two dots (`..`) — often cleverly referred to as *dot-dot* — also have special meanings. A single dot (`.`) indicates the current directory, whereas two dots (`..`) indicate the parent directory. For example, if the current directory is `/usr/share`, you go one level up to `/usr` by typing the following:

```
cd ..
```

Commands for directory listings and permissions

You can get a directory listing by using the `ls` command. By default, the `ls` command — without options — displays the contents of the current directory in a compact, multicolumn format. For example, type the next two commands to see the contents of the `/etc/X11` directory:

```
cd /etc/X11
ls
```

The output looks like this. (On the console, you see some items in different colors.)

```
X Xsession.d cursors rgb.txt xkb
XF86Config-4 Xsession.options default-display-manager restart xserver
Xresources Xwrapper.config fonts sysconfig xsm
Xsession app-defaults gdm xinit
```

From this listing (without the colors), you can't tell whether an entry is a file or a directory. To tell the directories and files apart, use the `-F` option with `ls`, like this:

```
ls -F
```

This time the output gives you some more clues about the file types:

```
X@ Xsession.d/ cursors/ rgb.txt xkb/
XF86Config-4 Xsession.options default-display-manager restart/ xserver/
Xresources/ Xwrapper.config fonts/ sysconfig/ xsm/
Xsession* app-defaults/ gdm@ xinit/
```

The output from `ls -F` shows the directory names with a slash (`/`) appended to them. Plain filenames appear as is. The at sign (`@`) appended to a filename (for example, notice the file named `X`) indicates that this file is a link to another file. (In other words, this filename simply refers to another file; it's a shortcut.) An asterisk (`*`) is appended to executable files. (`Xsession`, for example, is an executable file.) The shell can run any executable file.

You can see even more detailed information about the files and directories with the `-l` option:

```
ls -l
```

For the `/etc/X11` directory, a typical output from `ls -l` looks like the following:

```
total 84
lrwxrwxrwx 1 root root 20 Jul 15 20:32 X -> /usr/bin/X11/XFree86
-rw-r--r-- 1 root root 2878 Jul 16 14:50 XF86Config-4
drwxr-xr-x 2 root root 4096 Jul 15 20:32 Xresources
-rwxr-xr-x 1 root root 3456 Jun 1 01:59 Xsession
drwxr-xr-x 2 root root 4096 Jul 15 20:34 Xsession.d
```

```
-rw-r--r-- 1 root root 217 Jun 1 01:59 Xsession.options
-rw----- 1 root root 771 Jul 15 20:32 Xwrapper.config
drwxr-xr-x 2 root root 4096 Jul 15 20:35 app-defaults
. . . lines deleted . . .
```

This listing shows considerable information about every directory entry — each of which can be a file or another directory. Looking at a line from the right column to the left, you see that the rightmost column shows the name of the directory entry. The date and time before the name show when the last modifications to that file were made. To the left of the date and time is the size of the file in bytes.

The file's group and owner appear to the left of the column that shows the file size. The next number to the left indicates the number of links to the file. (A *link* is like a shortcut in Windows.) Finally, the leftmost column shows the file's permission settings, which determine who can read, write, or execute the file.



The first letter has a special meaning, as the following list shows:

- ◆ **l**: The file is a *symbolic link* to another file. In other words, it's a shortcut to something else.
- ◆ **d**: The file is a directory. It will appear as a folder in a GUI.
- ◆ **- (hyphen)**: The file is normal. By *normal*, I mean that it isn't a directory, a link, or anything else odd. Most of the items on your system are just normal files.
- ◆ **b**: The file represents a block device, such as a disk drive.
- ◆ **c**: The file represents a character device, such as a serial port or a terminal.



After that first letter, the leftmost column shows a sequence of nine characters, which appear as `rw-rw-rw-` when each letter is present. Each letter indicates a specific permission. A hyphen (-) in place of a letter indicates no permission for a specific operation on the file. Think of these nine letters as three groups of three letters (`rw-`), interpreted as follows:

- ◆ **Leftmost `rw-` group**: Controls the read, write, and execute permission of the file's owner. In other words, if you see `rw-` in this position, the file's owner can read (`r`), write (`w`), and execute (`x`) the file. A hyphen in the place of a letter indicates no permission. Thus the string `rw-` means the owner has read and write permission but not execute permission. Although executable programs (including shell programs) typically have execute permission, directories treat execute permission as equivalent to *use* permission: A user must have execute permission on a directory before he or she can open and read the contents of the directory.

- ◆ **Middle `rwX` group:** Controls the read, write, and execute permission of any user belonging to that file's group.
- ◆ **Rightmost `rwX` group:** Controls the read, write, and execute permission of all other users (collectively thought of as *the world*).

Thus, a file with the permission setting `rwX-----` is accessible only to the file's owner, whereas the permission setting `rwXr--r--` makes the file readable by the world.

An interesting feature of the `ls` command is that it doesn't list any file whose name begins with a period. To see these files, you must use the `ls` command with the `-a` option, as follows:

```
ls -a
```

Try this command in your home directory and then compare the result with what you see when you don't use the `-a` option:

1. Type `cd` to change to your home directory.
2. Type `ls -F` to see the files and directories in your home directory.
3. Type `ls -aF` to see everything, including hidden files.



Most Linux commands take single-character options, each with a hyphen as a prefix. When you want to use several options, type a hyphen and *concatenate* (string together) the option letters, one after another. Thus `ls -al` is equivalent to `ls -a -l` as well as `ls -l -a`.

Commands for changing permissions and ownerships

You may need to change a file's permission settings to protect it from others. Use the `chmod` command to change the permission settings of a file or a directory.

To use `chmod` effectively, you have to specify the permission settings. A good way is to concatenate letters from the columns of Table 4-4 in the order shown (Who/Action/Permission).

| <i>Who</i> | <i>Action</i> | <i>Permission</i> |
|------------|-----------------|-------------------|
| u (user) | + (add) | r (read) |
| g (group) | - (remove) | w (write) |
| o (others) | = (assign) | x (execute) |
| a (all) | s (set user ID) | |



You use only the single character from each column — the text in parentheses is for explanation only.

For example, to give everyone read access to all files in a directory, pick *a* (for *all*) from the first column, *+* (for *add*) from the second column, and *r* (for *read*) from the third column to come up with the permission setting *a+r*. Then use the set of options with `chmod`, like this:

```
chmod a+r *
```

On the other hand, to permit everyone to execute one specific file, type

```
chmod a+x filename
```



Suppose you have a file named `mystuff` that you want to protect. You can make it accessible to no one but you if you type the following commands, in this order:

```
chmod a-rwx mystuff
chmod u+rw mystuff
```

The first command turns off all permissions for everyone, and the second command turns on the read and write permissions for the owner (you). Type `ls -l` to verify that the change took place. (You see a permission setting of `-rw-----`.)

Sometimes you have to change a file's user or group ownership for everything to work correctly. For example, suppose you're instructed (by a manual, what else?) to create a directory named `cups` and give it the ownership of user ID `lp` and group ID `sys`. How do you do it?

Well, you can log in as `root` and create the `cups` directory with the command `mkdir`:

```
mkdir cups
```

If you check the file's details with the `ls -l` command, you see that the user and group ownership is `root root`.



To change the owner, use the `chown` command. For example, to change the ownership of the `cups` directory to user ID `lp` and group ID `sys`, type

```
chown lp.sys cups
```

Commands for working with files

To copy files from one directory to another, use the `cp` command. If you want to copy a file to the current directory but retain the original name, use a period (`.`) as the second argument of the `cp` command. Thus the following

command copies the `Xresources` file from the `/etc/X11` directory to the current directory (denoted by a single period):

```
cp /etc/X11/Xresources .
```

The `cp` command makes a new copy of a file and leaves the original intact.



If you want to copy the entire contents of a directory — including all subdirectories and their contents — to another directory, use the command `cp -ar sourcedir destdir`. (This command copies everything in the `sourcedir` directory to `destdir`.) For example, to copy all files from the `/etc/X11` directory to the current directory, type the following command:

```
cp -ar /etc/X11 .
```



To move a file to a new location, use the `mv` command. The original copy is gone, and a new copy appears at the destination. You can use `mv` to rename a file. If you want to change the name of `today.list` to `old.list`, use the `mv` command, as follows:

```
mv today.list old.list
```

On the other hand, if you want to move the `today.list` file to a subdirectory named `saved`, use this command:

```
mv today.list saved
```

An interesting feature of `mv` is that you can use it to move entire directories (with all their subdirectories and files) to a new location. If you have a directory named `data` that contains many files and subdirectories, you can move that entire directory structure to `old_data` by using the following command:

```
mv data old_data
```

To delete files, use the `rm` command. For example, to delete a file named `old.list`, type the following command:

```
rm old.list
```



Be careful with the `rm` command — especially when you log in as `root`. You can inadvertently delete important files with `rm`.

Commands for working with directories

To organize files in your home directory, you have to create new directories. Use the `mkdir` command to create a directory. For example, to create a directory named `images` in the current directory, type the following:

```
mkdir images
```

After you create the directory, you can use the `cd images` command to change to that directory.



You can create an entire directory tree by using the `-p` option with the `mkdir` command. For example, suppose your system has a `/usr/src` directory and you want to create the directory tree `/usr/src/book/java/examples/applets`. To create this directory hierarchy, type the following command:

```
mkdir -p /usr/src/book/java/examples/applets
```



When you no longer need a directory, use the `rmdir` command to delete it.

You can delete a directory only when the directory is empty.

To remove an empty directory tree, you can use the `-p` option, like this:

```
rmdir -p /usr/src/book/java/examples/applets
```

This command removes the empty parent directories of `applets`. The command stops when it encounters a directory that's not empty.

Commands for finding files

The `find` command is useful for locating files (and directories) that meet your search criteria.

When I began using Unix many years ago (Berkeley Unix in the early 1980s), I was confounded by the `find` command. I stayed with one basic syntax of `find` for a long time before graduating to more complex forms. The basic syntax that I discovered first was for finding a file anywhere in the file system. Here's how it goes: Suppose you want to find any file or directory with a name that starts with `gnome`. Type the following `find` command to find these files:

```
find / -name "gnome*" -print
```

If you're not logged in as `root`, you may get a bunch of error messages. If these error messages annoy you, just modify the command as follows and the error messages are history. (Or, as Unix aficionados say, "Send 'em to the bit bucket.")

```
find / -name "gnome*" -print 2> /dev/null
```

This command tells `find` to start looking at the `root` directory (`/`) to look for filenames that match `gnome*` and to display the full pathname of any matching file. The last part (`2> /dev/null`) simply sends the error messages to a special file that's the equivalent of simply ignoring them.

You can use variations of this simple form of `find` to locate a file in any directory (as well as any subdirectories contained in the directory). If you forget where in your home directory you've stored all files named `report*` (names that start with `report`), you can search for the files by using the following command:

```
find ~ -name "report*" -print
```

When you become comfortable with this syntax of `find`, you can use other options of `find`. For example, to find only specific types of files (such as directories), use the `type` option. The following command displays all top-level directory names in your Linux system:

```
find / -type d -maxdepth 1 -print
```

You probably don't have to use the complex forms of `find` in a typical Linux system. But if you ever need to, you can look up the rest of the `find` options by using the following command:

```
man find
```



An easy way to find all files that match a name is to use the `locate` command, which searches a periodically updated database of files on your system. For example, here's a typical output I get when I type **locate Xresources** on a Debian system (the output may differ based on your distribution):

```
/etc/X11/Xresources  
/etc/X11/Xresources/xbase-clients  
/etc/X11/Xresources/xfree86-common
```



The `locate` command isn't installed by default in some Linux distributions. To install it, open the Add/Remove Software application for your distribution and search for `locate`. Then select the package from the search results and click Accept to install it.

Commands for mounting and unmounting

Suppose you want to access the files on this book's companion DVD-ROM when you're logged in at a text console (with no GUI to help you). To do so, you have to first mount the DVD-ROM drive's file system on a specific directory in the Linux file system.



Start by looking at the `/etc/fstab` file for clues to the name of the CD-ROM device. For example, some Linux distributions use the device name `/dev/cdrom` to refer to CD/DVD-ROM drives, whereas others may use device names such as `/dev/hdc`, `/dev/cdroms/cdrom0`, or `/dev/cdrecorder` (for a DVD/CD-R drive). The entry in `/etc/fstab` file also tells you the directory where that distribution expects the CD/DVD to be mounted. Some



distributions use `/media/cdrom` as the mount point, whereas others use `/media/cdrom0`, or `/media/cdrecorder`.

It is customary to use the `cdrom` term to mean both CD-ROM and DVD-ROM.

Log in as `root` (or type `su` - to become `root`), insert the DVD-ROM in the DVD drive, and then type the following command:

```
mount /dev/hdc /media/cdrom0
```

This command mounts the file system on the device named `/dev/hdc` (an IDE DVD/CD-ROM drive) on the `/media/cdrom0` directory (which is also called the *mount point*) in the Linux file system.

After the `mount` command successfully completes its task, you can access the files on the DVD-ROM by referring to the `/media/cdrom0` directory as the top-level directory of the disc. In other words, to see the contents of the DVD-ROM, type

```
ls -F /media/cdrom0
```

When you've finished using the DVD-ROM — and before you eject it from the drive — you have to unmount the disc drive with the following `umount` command:

```
umount /dev/hdc
```



You can mount devices on any empty directory on the file system. However, each distribution has customary locations with directories meant for mounting devices. For example, some distributions use directories in `/mnt` whereas others use the `/media` directory for the mount points.

Commands for checking disk-space usage

You can use two simple commands — `df` and `du` — to check the disk-space usage on your system. The `df` command shows you a summary of disk-space usage for all mounted devices. For example, when I type `df` on a PC with many mounted storage devices, here's what I get as output:

```
Filesystem 1K-blocks Used Available Use% Mounted on
/dev/hdb6 28249372 2377292 25872080 9% /
tmpfs 383968 12 383956 1% /dev/shm
/dev/hda5 5766924 1422232 4051744 26% /ubuntu/boot
/dev/hda7 6258100 2989200 2951004 51% /debian/boot
/dev/hda9 5766924 1422232 4051744 26% /ubuntu
/dev/hda10 5766924 1872992 3600984 35% /mepis
/dev/hda11 6258100 2989200 2951004 51% /debian
/dev/hdb3 19558500 1370172 18188328 8% /xandros
/dev/hda2 16087676 10593364 5494312 66% /windows/C
/dev/hdb1 107426620 9613028 97813592 9% /windows/D
```

This table lists the device, the total kilobytes of storage, how much of that memory is in use, how much is available, the percentage being used, and the mount point.



To see the output of `df` in a more readable format, type `df -h`. The output follows:

```
Filesystem Size Used Avail Use% Mounted on
/dev/hdb6 27G 2.3G 25G 9% /
tmpfs 375M 12K 375M 1% /dev/shm
/dev/hda5 5.5G 1.4G 3.9G 26% /ubuntu/boot
/dev/hda7 6.0G 2.9G 2.9G 51% /debian/boot
/dev/hda9 5.5G 1.4G 3.9G 26% /ubuntu
/dev/hda10 5.5G 1.8G 3.5G 35% /mepis
/dev/hda11 6.0G 2.9G 2.9G 51% /debian
/dev/hdb3 19G 1.4G 18G 8% /xandros
/dev/hda2 16G 11G 5.3G 66% /windows/C
/dev/hdb1 103G 9.2G 94G 9% /windows/D
```

If you compare this output with the output of the plain `df` (the preceding listing), you see that `df -h` prints the sizes with terms like `M` for megabytes and `G` for gigabytes. These are easier to understand than `1K-blocks`.

The other command, `du`, is useful for finding out how much space a directory takes up. For example, type `du /etc/X11` to view the contents of all the directories in the `/etc/X11` directory. (This directory contains X Window System configuration files.) You see the following:

```
12 /etc/X11/Xresources
36 /etc/X11/Xsession.d
272 /etc/X11/app-defaults
20 /etc/X11/cursors
12 /etc/X11/xinit
. . . lines deleted . . .
12 /etc/X11/fonts/misc
8 /etc/X11/fonts/100dpi
8 /etc/X11/fonts/75dpi
8 /etc/X11/fonts/Speedo
8 /etc/X11/fonts/Type1
48 /etc/X11/fonts
2896 /etc/X11
```

Each directory name is preceded by a number — which tells you the number of kilobytes of disk space used by that directory. Thus the `/etc/X11` directory uses 2896KB (or about 2.9MB) of disk space. If you simply want the total disk space used by a directory (including all the files and subdirectories contained in that directory), use the `-s` option, as follows:

```
du -s /etc/X11
2896 /etc/X11
```

The `-s` option causes `du` to print just the summary information for the entire directory.



Just as `df -h` prints the disk-space information in megabytes and gigabytes, you can use the `du -h` command to view the output of `du` in more readable form. For example, here's how I combine it with the `-s` option to see the space that I'm using in my home directory (`/home/edulaney`):

```
du -sh /home/edulaney
645M /home/edulaney
```

Chapter 5: Introducing Linux Applications

In This Chapter

- ✓ Taking stock of typical Linux applications
- ✓ Trying out the office applications
- ✓ Playing with multimedia
- ✓ Working with images

Each Linux distribution comes with plenty of applications for all your diverse computing needs, as you can see by simply looking at the menus in the GUI desktops. Often, more than one application of the same type exists. Most distributions come with the LibreOffice office application suite that provides a word processor, spreadsheet, presentation software, and more. You'll find many choices for CD players and multimedia players, plus games, utility programs, and other useful tools, such as a scanner and digital camera applications. Some commercial distributions come with commercial office suites as well.



When it comes to playing *multimedia* (audio and video in various formats, such as MP3, MP4, and QuickTime), freely available Linux distributions rarely come with the appropriate decoders because of licensing restrictions; the multimedia application runs but cannot play the MP3 file or the DVD movie because it lacks a decoder. Commercial distributions usually come with some of these decoders.

This chapter offers an overview of some Linux applications. After you read about these applications, you can explore them further and have them at your disposal when needed. This chapter also provides an introduction to the GUI file managers, which allow you to browse and manipulate individual files.

Taking Stock of Linux Applications

A list of all the Linux applications available could take up much of the bulk of this book. A major application almost always has a website where you can get more information about it. Each Linux distribution comes with many applications and utilities; this chapter is but a brief sampling of what is available.

Typically, as you install a Linux distribution, you must select specific groups of applications to install. The exact list of applications on your Linux system depends on the choices you make during the installation.

It's easy to install missing applications in Debian (and Debian-based distributions, such as Ubuntu) as long as you have a broadband (cable or DSL) connection to the Internet. For example, to see whether the K3b CD/DVD burner exists for Debian, type **apt-cache search k3b**. You get output similar to the following:

```
k3b - A sophisticated KDE cd burning application
k3b-i18n - Internationalized (i18n) files for k3b
k3blibs - The KDE cd burning application library - runtime files
k3blibs-dev - The KDE cd burning application library - development files
```

Next, type **apt-get install k3b** and a few moments later you'll have K3b installed on your Debian system. This ease of installing (or upgrading) software is why Debian users swear by apt-get (even though it's a command-line tool).

Introducing Office Applications and Tools

Word processor, spreadsheet, presentation software, calendar, calculator — these are some office staples. Most Linux distributions come with the LibreOffice suite of office applications and tools. You can try all of them one by one and see which one takes your fancy. Each application is fairly intuitive to use. Although some nuances of the user interface may be new to you, you'll become comfortable with the interface after using it a few times. This section briefly introduces the following applications, as well as some other commercially available office applications for Linux:

- ◆ **LibreOffice Suite:** A Microsoft Office–like office suite with the Writer word processor, the Calc spreadsheet program, the Impress presentation program, the Draw drawing and illustration application, and Math, a mathematical formula editor
- ◆ **Contact:** A personal information management application in KDE
- ◆ **Calculators:** A GNOME calculator and KDE calculator
- ◆ **Aspell:** A spelling checker

LibreOffice.org office suite

LibreOffice.org is not only a website, but also an office suite similar to major office suites such as Microsoft Office. Its main components are the Writer word processor, the Calc spreadsheet, and the Impress presentation program.

You can easily start LibreOffice.org — either the overall suite or an individual application — from most GUI desktops by clicking a panel icon or by making a choice from the main menu. For example, in Ubuntu, you can click a desktop icon to open the initial window of the LibreOffice.org suite. You can create new documents or open existing documents (which can be Microsoft Office files as well) from the main window.

Writer

Choosing File→New→Text Document from any LibreOffice.org window starts LibreOffice.org Writer with a blank document in its main window. Using Writer is simple — if you're familiar with Microsoft Word, you should have no trouble finding your way around Writer. You can type text into the blank document, format text, and save text.

You can also open documents that you've prepared with Microsoft Word on a Windows machine. Figure 5-1 shows a Microsoft Word document opened in LibreOffice Writer.

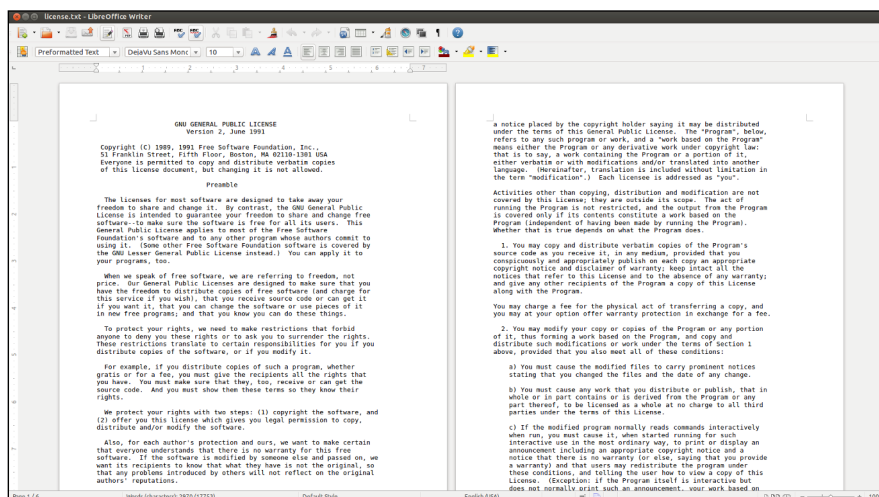

Figure 5-1:
You can
prepare
documents
in Libre-
Office
Writer.

When you save a document, Writer saves it in LibreDocument text format by default, in a file with the .odt extension.



If you need to share Writer documents with Microsoft Word, you can save the documents in several formats, including Microsoft Word and Rich Text (.rtf) formats.

Writer is simple and intuitive to use. If you need help, online help is available by choosing Help from the Writer menu (or pressing F1 in newer versions). This brings up the Help window with help information on Writer. You can then click the links to view specific help information.

Calc

Calc is the spreadsheet program in the LibreOffice application suite. To start Calc, choose Spreadsheet from the Office category in the main menu or choose File→New→Spreadsheet from any LibreOffice window. Calc displays its main window, which looks similar to that of Windows-based spreadsheets such as Microsoft Excel. (Calc can read and write Microsoft Excel-format spreadsheet files.)

Use Calc in the same way you use Microsoft Excel. You can type entries in cells, use formulas, and format the cells. (For example, you can specify the type of value and the number of digits after the decimal point.) Figure 5-2 shows a typical spreadsheet in Calc.

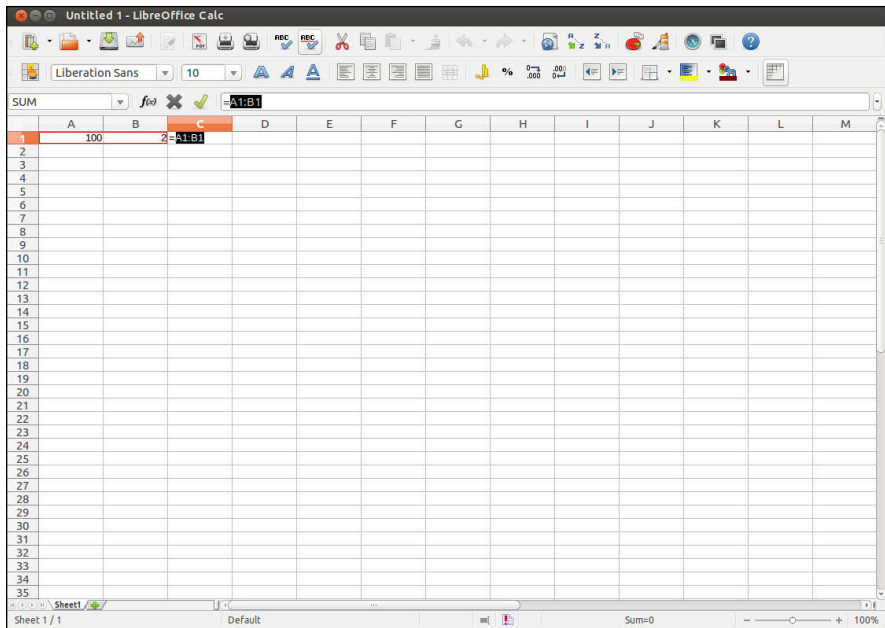

Figure 5-2:
Prepare
your
spread-
sheets with
LibreOffice
Calc.

When preparing the spreadsheet, use formulas in the same format that you would in Microsoft Excel. For example, use the formula **SUM(D2:D6)** to add the entries from cell D2 to D6. To set cell D2 as the product of the entries A2 and C2, type **=A2*C2** in cell D2. To find out more about the functions available in LibreOffice.org Calc, choose Help→LibreOffice.org Help from the menu (or press F1 in newer versions). This opens the LibreOffice.org Help window, from which you can browse the functions by category and click a function to read more about it.

To save the spreadsheet, choose File→Save As. A dialog box appears, from which you can specify the file format, the directory location, and the name of the file. When you save a document, Calc saves it in LibreDocument spreadsheet format in a file with the .ods extension by default.

LibreOffice.org Calc can save the file in several other formats, including Microsoft Excel, as well as text file with comma-separated values (CSV).



If you want to exchange files with Microsoft Excel, save the spreadsheet in Microsoft Excel format (choose an appropriate version for Excel). Then you can transfer that file to a Windows system and open it in Microsoft Excel.

Impress

Impress is similar to Microsoft PowerPoint; it allows you to create unique and creative slide presentations for a variety of purposes. To run Impress, choose Presentation from the Office category in the main menu or choose File→New→Presentation from any LibreOffice window.

When you first open Impress, the program prompts you for the presentation style and template. To begin working, select Empty presentation and click Create. To open an existing document, select the appropriate option from the Presentation Wizard and click Open. Then select the presentation file you want to open. You can open Microsoft PowerPoint files in Impress. Figure 5-3 shows a typical slide presentation in Impress.

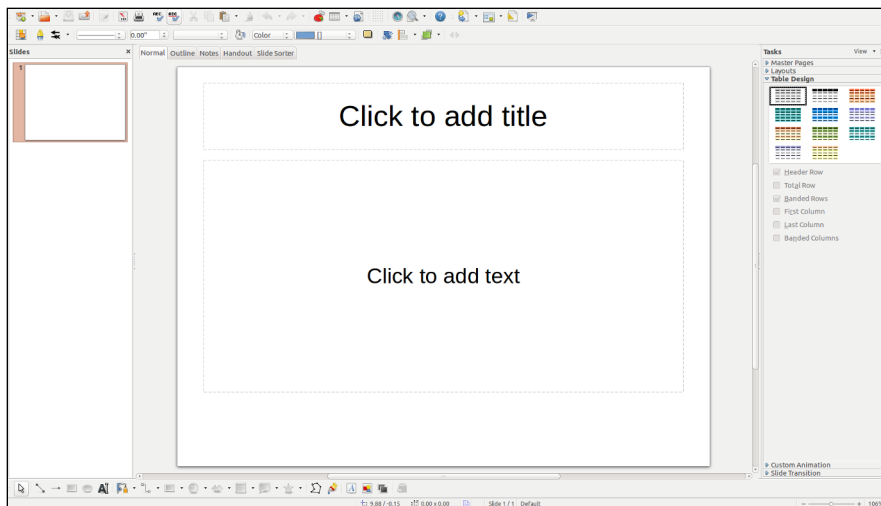

Figure 5-3: You can prepare presentations in LibreOffice Impress.

The Impress window shows the first slide together with an outline view of the slides along the left side. The exact appearance depends on the document type and template you select. You can begin adding text and other graphic objects such as images, text, and lines to the slide.

To insert a new slide, choose **Insert**→**Slide** from the menu. A blank slide appears. You can then add text and graphics to that new slide.

To save a presentation, choose **File**→**Save**. For new documents, you have to provide a filename and select the directory to which you want to save the file.



If you want to share the slides with someone who uses Microsoft PowerPoint, save the presentation in Microsoft PowerPoint format.

Calendars

KDE comes with **Kontact** — an application that integrates existing KDE applications such as **KMail** mail reader and the **KOrganizer** calendar program into a single graphical personal information manager. You can start **Kontact** from panel icons or the main menu. (The location of the menu entry depends on the Linux distribution.)

When **Kontact** starts, it usually displays a summary window with information about new e-mail messages, upcoming scheduled events, and more. You can explore each application individually by clicking the icons in the left pane of the **Kontact** window.

To add an event or appointment for a specific date and time, select the date from the calendar, double-click the time, and type a brief description of the appointment in the **New Event** dialog box that appears. Click **OK** when you're finished.

Calculators

You have a choice of the **GNOME** calculator or the **KDE** calculator. Both are scientific calculators; you can do typical scientific calculations (such as square root and inverse) as well as trigonometric functions (such as sine, cosine, and tangent).

To use the calculator, look for it in the **Utilities** or **Accessories** category of the main menu. **Figure 5-4** shows the **KDE** calculator in **SUSE**.

Figure 5-4:
Do your
calculations
in the **KDE**
calculator.

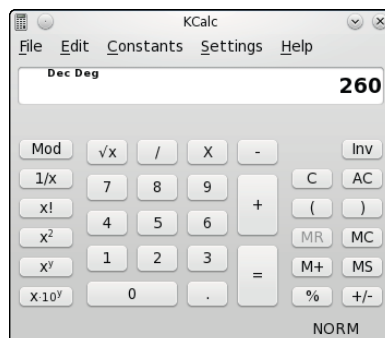

You can display additional buttons by selecting options from the Settings menu. For example, choose Settings⇨Statistic Buttons to show buttons that enable you to perform statistical calculations with the calculator.

Checking out Multimedia Applications

Most Linux distributions include quite a few multimedia applications — mostly multimedia audio players and CD players, but also applications for using digital cameras and burning CD-ROMs and DVDs. To play some other multimedia files (such as MPEG video), you may have to download and install additional software on your Linux system. Here's a quick sketch of a few typical multimedia tasks and the applications you can use to perform these tasks:

- ◆ **Using digital cameras:** Use a digital camera tool to download photos from your digital camera in Linux (or simply access the camera as a USB mass storage device).
- ◆ **Playing audio CDs:** Use one of many audio CD players that come with Linux.
- ◆ **Playing sound files:** Use Rhythmbox or XMMS multimedia audio players. (You have to download some additional software to play MP3 files with Rhythmbox or XMMS.) You can also download other players from the Internet.
- ◆ **Burning a CD or DVD:** Use a DVD or CD burner, such as K3b, to burn audio and data CDs/DVDs.

Using a digital camera

Most Linux distributions come with a digital camera application that you can use to download pictures from digital cameras. For example, SUSE and Xandros come with digiKam, which works with many makes and models of digital cameras. Depending on the model, the cameras can connect to the serial port or the Universal Serial Bus (USB) port.

To use digiKam with your digital camera, follow these steps:

1. **Connect your digital camera to the serial port or USB port (whichever interface the camera supports) and turn on the camera.**
2. **Start digiKam.**
Look for digiKam in the main menu under the Graphics or Images submenu. The first time you open digiKam, you will be asked to specify a default location in which to store images, and to choose a number of other configuration preferences.
3. **From the digiKam menu, choose Settings⇨Configure digiKam.**
A configuration dialog box appears.

4. Click the Cameras tab in the dialog box, and then click Auto Detect.

If your camera is supported and the camera is configured to be in PTP (Picture Transfer Protocol) mode, the camera is detected. If not, you can get the photos from your camera by using an alternate method (described after these steps).

5. Choose your camera model from the Camera menu.

A new window appears and, after a short while, displays the photos in the camera.

6. Click the thumbnails to select the images you want to download; then choose Camera → Download to download the images.

digiKam downloads the images. You can save these files in a folder and edit the photos in The GIMP or your favorite photo editor.



Don't despair if digiKam doesn't recognize your digital camera. You can still access the digital camera's storage medium (compact flash card, for example) as a USB mass storage device, provided your camera supports USB mass storage. To access the images on your USB digital camera, use the following steps.

1. Read the camera manual and use the menu options of the camera to set the USB mode to Mass Storage.

If the camera doesn't support USB mass storage, you can't use this procedure to access the photos. If the camera supports the Picture Transfer Protocol mode, you can use digiKam to download the pictures.

2. Connect your digital camera to the USB port by using the cable that came with the camera. Then turn on the camera.

Linux detects the camera and opens the contents of the camera in a file manager window.

3. Click to select photos and copy them to your hard drive by dragging and dropping them into a selected folder.

4. Close the file manager window, disconnect the USB cable from the PC, and turn off the camera.

Whether you're using a digital camera tool such as digiKam or accessing your camera as you would any other storage device, Linux makes it easy to get your pictures onto your computer.

Playing audio CDs

All Linux distributions come with either the GNOME or KDE CD-player applications. To play an audio CD, you need a sound card, and that sound card must be configured to work in Linux.

In some distributions, when you insert an audio CD into the drive, a dialog box appears and asks whether you want to play the CD with the CD player. If this dialog box doesn't appear, locate an audio CD player by choosing Applications⇨Sound and Video from the main menu.

The KDE CD player displays the title of the CD and the name of the current track. The CD player gets the song titles from <http://freedb.org> — a free, open source CD database on the Internet (freedb.org at port 888). You need an active Internet connection for the CD player to download song information from the CD database. After the CD player downloads information about a particular CD, it caches that information in a local database for future use. The CD player user interface is intuitive, and you can figure it out easily. One nice feature is that you can select a track by title.

Playing sound files

You can use Rhythmbox or XMMS to open and play sound files (for example, MP3 files). Users with large MP3 music libraries usually like Rhythmbox because it can help organize their music files. You can start Rhythmbox by choosing the music player application from the main menu in several distributions, including Debian and Fedora. When you first start Rhythmbox, it displays an assistant that prompts you for the location of your music files so that Rhythmbox can manage your music library.

After you identify the locations of music files, Rhythmbox starts and displays the library in an organized manner. You can then select music and play it.

XMMS is another music player that can play many types of sound files, including Ogg Vorbis, FLAC (Free Lossless Audio Codec, an audio file format similar to MP3), and Windows WAV.

You can start XMMS by choosing the audio player application from the main menu (look under Multimedia or Sound & Video). After XMMS starts, you can open a sound file (such as an MP3 file) by choosing Window Menu⇨Play File or by pressing L. Then select one or more music files from the Load File dialog box. Click the Play button, and XMMS starts playing the sound file.

Burning a CD or DVD

Nowadays, most GUI file managers have the capability to burn CDs. For example, Nautilus File Manager and Xandros File Manager have built-in features for burning CDs and DVDs. Linux distributions also come with standalone GUI programs that enable you to easily burn CDs and DVDs. For example, K3b is a popular CD/DVD-burning application for KDE that's available in Knoppix and SUSE.

Most CD-burning applications are simple to use. You basically gather the files that you want to burn to the CD or DVD and then start the burning process. Of course, for this to work, your PC must have a CD or DVD burner installed.

The upper part of the K3b window is for browsing the file system to select what you want to burn onto a CD or DVD. The upper-left corner shows the CD-writer device installed.

To burn a CD, you start with one of the projects shown in the lower part of the K3b window — New Audio CD Project, for example, or New Data DVD Project. Then you have to add files and, finally, burn the project to the CD or DVD by choosing Project→Burn or pressing Ctrl+B. For an audio CD, you can drag and drop MP3 files as well as audio tracks.



K3b needs the external command-line programs `cdrecord` and `cdrdao` to burn CDs. K3b also needs the `growisofs` program to burn DVDs.



If you get an error message about missing `cdrdao` in Debian, make sure that your Debian system is connected to the Internet, and then type **apt-get install cdrdao** to install it.

Using Graphics and Imaging Apps

You can use graphics and imaging applications to work with images and graphics (line drawings and shapes). Two of the most popular of these applications are

- ◆ **The GIMP (GNU Image Manipulation Program):** A program for viewing and performing image-manipulation tasks, such as photo retouching, image composition, and image creation.
- ◆ **Gnome Ghostview (GGv):** A graphical application capable of displaying PostScript files.

The GIMP

The GIMP is an image-manipulation program written by Peter Mattis and Spencer Kimball and released under the GNU General Public License (GPL). Most Linux distributions come with this program, although you may have to specifically select a package to install it. The GIMP is comparable to other image-manipulation programs, such as Adobe Photoshop and Corel PHOTO-PAINT.

To try out The GIMP, look for it under the Graphics category in the main menu. When you start The GIMP, it displays a window with copyright and license information. Click the Continue button to proceed with the installation. The next screen shows the directories to be created when you proceed with a personal installation of The GIMP.

If you can't find The GIMP under the Graphics category, choose Add/Remove Software from the System Settings menu and install it from there.

The GIMP installation involves creating a directory in your home directory and placing a number of files there. This directory essentially holds information about any changes to user preferences you may make to The GIMP. Go ahead and click the Continue button at the bottom of the window. The GIMP creates the necessary directories, copies the necessary files to those directories, and guides you through a series of dialog boxes to complete the installation.

When the installation is finished, click the Continue button. The GIMP then loads any *plug-ins* — external modules that enhance its functionality. It displays a startup window that shows a message about each plug-in as it loads. After finishing the startup, The GIMP displays a tip of the day in a window. You can browse the tips and click the Close button to close the Tip window. At the same time, The GIMP displays a number of other windows, including a main navigation window titled The GIMP, a Toolbox window (usually on the left side), a Brush Selection window, and a Layers, Channels, Paths window. The center navigation window gives you access to new images to work with, image-editing functions, and a number of effect filters that you can apply to the image. The Toolbox window lets you quickly select a number of important image-manipulation tools.

To open an image file in The GIMP, choose File⇨Open. The Load Image dialog box appears. You can change directories and select the image file that you want to open. The GIMP can read all common image file formats, such as GIF, JPEG, TIFF, PCX, BMP, PNG, and PostScript. After you select the file and click OK, The GIMP loads the image into a new window.

The Toolbox window has many buttons that represent the tools you use to edit the image and apply special effects. You can get pop-up help on each tool button by placing the mouse pointer over the button. You can select a tool by clicking the tool's button, and you can apply that tool's effects to the image to see what it does.

When you right-click the image window, The GIMP displays a pop-up menu that has most of the options from The GIMP's top toolbar.

You can do much more than just load and view images with The GIMP, but a complete discussion of all its features is beyond the scope of this book. If you want to try the other features of The GIMP, consult *The GIMP User Manual* (GUM), available online at <http://www.gimp.org/docs/>. You can also choose Help⇨GIMP Online⇨User Manual Website to access the online documentation for The GIMP. (You need an Internet connection for this command to work.)

Visit The GIMP home page at www.gimp.org to find the latest news about The GIMP as well as links to other resources.

GNOME Ghostview

GNOME Ghostview is a graphical application ideal for viewing and printing PostScript or PDF documents. For a long document, you can view and print selected pages. You can also view the document at various levels of magnification by zooming in or out.

To run GNOME Ghostview in Fedora, choose Graphics⇨PostScript Viewer from GUI desktop. The GNOME Ghostview application window appears. In addition to the menu bar and toolbar along the top edge, a vertical divide splits the main display area of the window into two parts.

To load and view a PostScript document in GNOME Ghostview, choose File⇨Open, or click the Open icon on the toolbar. GNOME Ghostview displays a File-Selection dialog box. Use this dialog box to navigate the file system and select a PostScript file. For example, select the file `tiger.ps` in the `/usr/share/ghostscript-8.64/examples` directory. (Use your system's version number of Ghostscript in place of `8.64`).

To open the selected file, click the Open File button in the File-Selection dialog box. GNOME Ghostview opens the selected file, processes its contents, and displays the output in its window.



GNOME Ghostview is useful for viewing various kinds of documents that come in PostScript format. (These files typically have the `.ps` extension.) You can also open PDF files — which typically have `.pdf` extensions — in GNOME Ghostview.

Chapter 6: Using Text Editors

In This Chapter

- ✓ Checking out different GUI text editors
- ✓ Working with the `ed` text editor
- ✓ Getting to know the `vi` text editor

Although the desktop provides a beautiful graphical interface that's a pleasure to work in, much goes on outside that interface. Most Linux system configuration files are text files. Additionally, Linux gives you the ability to create shell scripts and interact with the operation of a number of programs — all by using text files.

When all is working as it should, you can edit (and even create) those files with graphical tools, but it's highly recommended that you also know how to edit them outside that interface, should a problem exist that keeps the X Window System from loading. Whether in the interface or not, you'll be using *text editors*, programs designed to interact with text files.

In this chapter, you're introduced to a few text editors — both GUI editors and text mode editors.

Using GUI Text Editors

Each of the GUI desktops — GNOME and KDE — comes with GUI text editors (text editors that have graphical user interfaces).

To use a GUI text editor, look in the main menu and search for text editors in an appropriate category. For example, in the GNOME desktop, choose Applications⇨Text Editor and this will open `gedit`. After you have a text editor up and running, you can open a file by clicking the Open button on the toolbar to display the Open File dialog box. You can change directories and then select the file to edit by clicking the OK button.

The GNOME text editor loads the file in its window. You can open more than one file at a time and move among them as you edit the files. Figure 6-1 shows a typical editing session with the editor.



Figure 6-1:
You can use
the GNOME
text editor
to edit text
files.

In this case, the editor has two files — a new file being written, and `motd` (from the `/etc` directory) — open for editing. The filenames appear as tabs below the toolbar of the editor's window. You can switch between the files by clicking the tabs. The current filename appears in the last line of the window.

If you open a file for which you have only read permission, the text `[Read Only]` is appended to the filename shown in the window title to indicate that the file is read-only and the location of the file is displayed at the top (such as `/etc`). The indication that the file is read-only often appears when a regular user is opening system files that only the `root` can modify.

The rest of the text editing steps are intuitive. To enter new text, click to position the cursor and begin typing. You can select text, copy, cut, and paste by using the buttons on the toolbar above the text editing area.

From the KDE desktop, you can start the KDE text editor (KWrite) by choosing `Applications` → `Accessories` → `Text Editor`. To open a text file, choose `File` → `Open` to display a dialog box. From this dialog box, you can go to the directory of your choice, select the file to open, and click `OK`. KWrite opens the file and displays its contents in the window; you can then edit the file, as shown in Figure 6-2.

Figure 6-2:
You can use
the KDE
KWrite text
editor to edit
files.

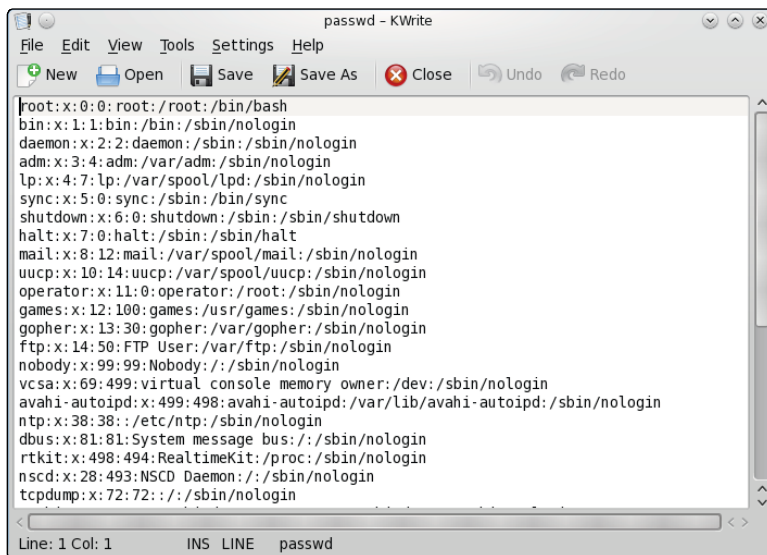

Text Editing with *ed* and *vi*

GUI text editors enable you to edit text files using the mouse and keyboard the same way as you use any word processor. Text mode editors are a different beast — you work using only the keyboard and you have to type cryptic commands to perform editing tasks, such as cutting and pasting text or entering and deleting text. Linux comes with two text mode text editors:

- ◆ *ed*: A line-oriented text editor
- ◆ *vi*: A full-screen text editor that supports the command set of an earlier editor named *ex*

The *ed* and *vi* editors are cryptic compared to the graphical text editors. However, you should still get to know the basic editing commands of *ed* and *vi* because sometimes these two may be the only editors available. For example, if Linux refuses to boot from the hard drive, you may have to boot from a CD, DVD, or flash drive. In that case, you have to edit system files with the *ed* editor because that editor is small enough to fit on the boot medium. I walk you through the basic text editing commands of *ed* and *vi* — they're not that hard.

Using *ed*

Typically, you have to use *ed* only when you boot a minimal version of Linux (for example, from the medium you've set up as a boot disk), and the system doesn't support full-screen mode. In all other situations, you can use the *vi* editor, which works in full-screen text mode.

When you use `ed`, you work in command mode or text input mode:

- ◆ **Command mode:** This mode is the default. In this mode, anything that you type is interpreted as a command. The `ed` text editor has a simple command set in which each command consists of one or more characters.
- ◆ **Text input mode:** This mode is for typing text. You can enter text input mode with the commands `a` (append), `c` (change), or `i` (insert). After entering lines of text, you can leave text input mode by entering a period (`.`) on a line by itself.

To practice editing a file, copy the `/etc/fstab` file to your home directory by issuing the following commands:

```
cd
cp /etc/fstab .
```

Now you have a file named `fstab` in your home directory. Type **`ed -p: fstab`** to begin editing a file in `ed`. The editor responds:

```
878
:
```

This example uses the `-p` option to set the prompt to the colon character (`:`) and opens the `fstab` file (in the current directory, which is your home directory) for editing. The `ed` editor opens the file, reports the number of characters in the file (878), displays the prompt (`:`), and waits for a command.



When you're editing with `ed`, make sure that you always turn on a prompt character (use the `-p` option). Without the prompt, distinguishing whether `ed` is in text input mode or command mode is difficult.

After `ed` opens a file for editing, the current line is the last line of the file. To see the current line number (the current line is the line to which `ed` applies your command), use the `. =` command, like this:

```
: . =
9
```

This output tells you that the `fstab` file has nine lines. (Your system's `/etc/fstab` file may have a different number of lines, in which case `ed` shows a different number.)

You can use the `1, $p` command to see all lines in a file, as the following example shows:

```
:1,$p
# This file is edited by fstab-sync - see 'man fstab-sync' for details
/dev/VolGroup00/LogVol100 / ext3 defaults 1 1
LABEL=/boot /boot ext3 defaults 1 2
/dev/devpts /dev/pts devpts gid=5,mode=620 0 0
/dev/shm /dev/shm tmpfs defaults 0 0
/dev/proc /proc proc defaults 0 0
/dev/sys /sys sysfs defaults 0 0
/dev/VolGroup00/LogVol01 swap swap defaults 0 0
/dev/scd0 /media/cdrecorder auto pamconsole,exec,noauto,managed 0 0
/dev/hdc /media/cdrom auto pamconsole,exec,noauto,managed 0 0
:
```

To go to a specific line, type the line number:

```
:2
```

The editor responds by displaying that line:

```
/dev/VolGroup00/LogVol100 / ext3 defaults 1 1
:
```

Suppose you want to delete the line that contains `cdrom`. To search for a string, type a slash (`/`) followed by the string that you want to locate:

```
:/cdrom
/dev/hdc /media/cdrom auto pamconsole,exec,noauto,managed 0 0
:
```

The editor locates the line that contains the string and then displays it. That line becomes the current line.

To delete the current line, use the `d` command as follows:

```
:d
:
```

To replace a string with another, use the `s` command. To replace `cdrom` with the string `cd`, for example, use this command:

```
:s/cdrom/cd/
:
```

To insert a line in front of the current line, use the `i` command:

```
:i
(type the line you want to insert)
.(type a single period to indicate you're done)
:
```

You can enter as many lines as you want. After the last line, enter a period (.) on a line by itself. That period marks the end of text input mode, and the editor switches to command mode. In this case, you can tell that `ed` switches to command mode because you see the prompt (:).

When you're happy with the changes, you can write them to the file with the `w` command. If you want to save the changes and exit, type `wq` to perform both steps at the same time:

```
:wq
857
```

The `ed` editor saves the changes in the file, displays the number of saved characters, and exits. If you want to quit the editor without saving any changes, use the `Q` command.

These examples give you an idea of how to use `ed` commands to perform the basic tasks of editing a text file. Table 6-1 lists some of the commonly used `ed` commands.

| Command | Does the Following |
|----------------|--|
| !command | Executes a shell command. (For example, !pwd displays the current directory.) |
| \$ | Goes to the last line in the buffer. |
| % | Applies a command that follows to all lines in the buffer. (For example, %p prints all lines.) |
| + | Goes to the next line. |
| +n | Goes to the <i>n</i> th next line (where <i>n</i> is a number you designate). |
| , | Applies a command that follows to all lines in the buffer. (For example, ,p prints all lines.) This command is similar to %. |
| - | Goes to the preceding line. |
| -n | Goes to the <i>n</i> th previous line (where <i>n</i> is a number you designate). |
| . | Refers to the current line in the buffer. |
| /text/ | Searches forward for the specified text. |
| ; | Refers to a range of lines — the current line through the last line in the buffer. |
| = | Prints the line number. |
| ?text? | Searches backward for the specified text. |
| ^ | Goes to the preceding line. (See also the - command.) |

| Command | Does the Following |
|-------------------|---|
| $\wedge n$ | Goes to the n th previous line (where n is a number you designate). (See also the $-n$ command.) |
| <i>a</i> | Appends the current line. |
| <i>c</i> | Changes the specified lines. |
| <i>d</i> | Deletes the specified lines. |
| <i>i</i> | Inserts text before the current line. |
| <i>n</i> | Goes to line number n (where n is a number you designate). |
| Press Enter | Displays the next line and makes that line current. |
| <i>q</i> | Quits the editor. |
| <i>Q</i> | Quits the editor without saving changes. |
| <i>r file</i> | Reads and inserts the contents of the file after the current line. |
| <i>s/old/new/</i> | Replaces an old string with a new one. |
| <i>u</i> | Undoes the last command. |
| <i>W file</i> | Appends the contents of the buffer to the end of the specified file. |
| <i>w file</i> | Saves the buffer in the specified file. (If no file is named, it saves in the default file — the file whose contents <i>ed</i> is currently editing.) |

Using *vi*

After you dabble with *ed*, you'll find *vi* is a dream come true, even though it's still a command-line editor. The *vi* editor is a full-screen text editor, so you can view several lines at the same time. Most Unix systems, including Linux, come with *vi*. Therefore, if you know the basic features of *vi*, you can edit text files on almost any Unix-based system.



When *vi* edits a file, it reads the file into a *buffer* — a block of memory — so you can change the text in the buffer. The *vi* editor also uses temporary files during editing, but the original file isn't altered until you save the changes.

To start the editor, type *vi* and follow it with the name of the file you want to edit, like this:

```
vi /etc/fstab
```

The *vi* editor then loads the file into memory and displays the first few lines in a text screen and positions the cursor on the first line, as shown in Figure 6-3.

Figure 6-3:
You can edit
files with
the vi full-
screen text
editor.

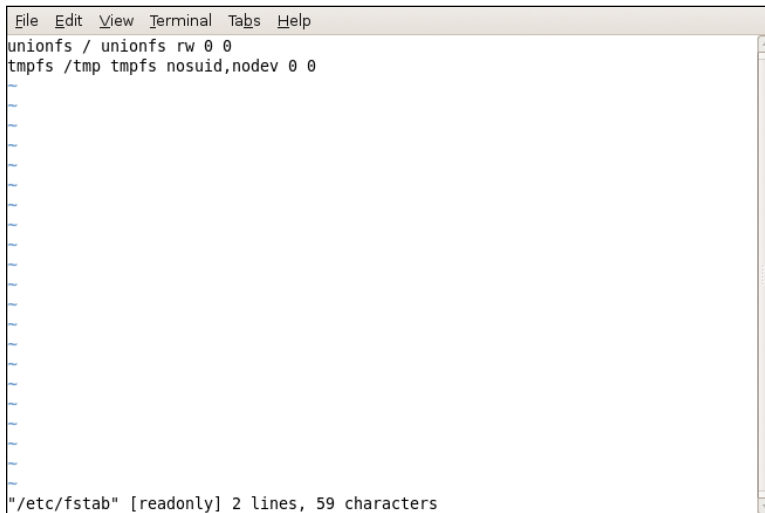

```
File Edit View Terminal Tabs Help
unionfs / unionfs rw 0 0
tmpfs /tmp tmpfs nosuid,nodev 0 0

"/etc/fstab" [readonly] 2 lines, 59 characters
```

The last line shows the pathname of the file as well as the number of lines (2) and the number of characters (59) in the file. In this case, the text `[readonly]` appears after the filename because I'm opening the `/etc/fstab` file while I'm logged in as a normal user (which means I don't have permission to modify the file). Later, the last line in the `vi` display functions as a command entry area. The rest of the lines display the file. If the file contains fewer lines than the screen, `vi` displays the empty lines with a tilde (`~`) in the first column.

The current line is marked by the cursor, which appears as a small black rectangle. The cursor appears on top of a character.

When using `vi`, you work in one of three modes:

- ◆ **Visual command mode:** This mode is the default. In this mode, anything that you type is interpreted as a command that applies to the line containing the cursor. The `vi` commands are similar to the `ed` commands.
- ◆ **Colon command mode:** You use this mode for reading or writing files, setting `vi` options, and quitting `vi`. All colon commands start with a colon (`:`). When you type the colon, `vi` positions the cursor on the last line and waits for you to type a command. The command takes effect when you press Enter.
- ◆ **Text input mode:** This mode is for typing text. You can enter text input mode with the command `a` (insert after cursor), `A` (append at end of line), `o` (open a line below the current one), `O` (open a line above the current one), or `i` (insert after cursor). After entering lines of text, you have to press Esc to leave text input mode and re-enter visual command mode.



One problem with all these modes is that you can't easily tell the current mode that *vi* is in. You may begin typing only to realize that *vi* isn't in text input mode, which can be frustrating.

If you want to make sure that *vi* is in command mode, just press Esc a few times. (Pressing Esc more than once doesn't hurt.)

To view online help in *vi*, type **:help** while in colon command mode. When you're finished with help, type **:q** to exit the Help screen and return to the file you're editing.

The *vi* editor initially positions the cursor on the first character of the first line, and one of the handiest things you can know is how to move the cursor around. To get a bit of practice, try the commands shown in Table 6-2.

| Key | Moves the Cursor |
|------------|----------------------------|
| ↓ | One line down |
| ↑ | One line up |
| ← | One character to the left |
| → | One character to the right |
| W | One word forward |
| B | One word backward |
| Ctrl+D | Half a screen down |
| Ctrl+U | Half a screen up |

You can go to a specific line number at any time by using the handy colon command. To go to line 6, for example, type the following and then press Enter:

```
:6
```

When you type the colon, *vi* displays the colon on the last line of the screen. From then on, *vi* uses any text you type as a command. You have to press Enter to submit the command to *vi*. In colon command mode, *vi* accepts all commands that the *ed* editor accepts — and then some.

To search for a string, first type a slash (/). The *vi* editor displays the slash on the last line of the screen. Type the search string and then press Enter. The *vi* editor locates the string and positions the cursor at the beginning of that string. Thus, to locate the string *cdrom* in the file */etc/fstab*, type

```
/cdrom
```

To delete the line that contains the cursor, type **dd**. The `vi` editor deletes that line of text and makes the next line the current one.

To begin entering text in front of the cursor, type **i**. The `vi` editor switches to text input mode. Now you can enter text. When you finish entering text, press `Esc` to return to visual command mode.

After you finish editing the file, you can save the changes in the file with the `:w` command. To quit the editor without saving any changes, use the `:q!` command. If you want to save the changes and exit, you can use the `:wq` command to perform both steps at the same time. The `vi` editor saves the changes in the file and exits. You can also save the changes and exit the editor by pressing `Shift+ZZ` (hold `Shift` down and press `Z` twice).

`vi` accepts a large number of commands in addition to the commands I just mentioned. Table 6-3 lists some commonly used `vi` commands, organized by task.

| Table 6-3 | |
|---------------------------|--|
| Common vi Commands | |
| <i>Command</i> | <i>Does the Following</i> |
| Insert Text | |
| <code>a</code> | Inserts text after the cursor. |
| <code>A</code> | Inserts text at the end of the current line. |
| <code>I</code> | Inserts text at the beginning of the current line. |
| <code>i</code> | Inserts text before the cursor. |
| Delete Text | |
| <code>D</code> | Deletes up to the end of the current line. |
| <code>dd</code> | Deletes the current line. |
| <code>dG</code> | Deletes from the current line to the end of the file. |
| <code>dw</code> | Deletes from the cursor to the end of the following word. |
| <code>x</code> | Deletes the character on which the cursor rests. |
| Change Text | |
| <code>C</code> | Changes up to the end of the current line. |
| <code>cc</code> | Changes the current line. |
| <code>J</code> | Joins the current line with the next one. |
| <code>rx</code> | Replaces the character under the cursor with <code>x</code> (where <code>x</code> is any character). |

| Command | Does the Following |
|---------------------------|---|
| Move Cursor | |
| h or ← | Moves one character to the left. |
| j or ↓ | Moves one line down. |
| k or ↑ | Moves one line up. |
| L | Moves to the end of the screen. |
| l or → | Moves one character to the right. |
| w | Moves to the beginning of the following word. |
| b | Moves to the beginning of the previous word. |
| Scroll Text | |
| Ctrl+D | Scrolls forward by half a screen. |
| Ctrl+U | Scrolls backward by half a screen. |
| Refresh Screen | |
| Ctrl+L | Redraws screen. |
| Cut and Paste Text | |
| yy | Yanks (copies) current line to an unnamed buffer. |
| P | Puts the yanked line above the current line. |
| p | Puts the yanked line below the current line. |
| Colon Commands | |
| : ! <i>command</i> | Executes a shell command. |
| :q | Quits the editor. |
| :q! | Quits without saving changes. |
| :r <i>filename</i> | Reads the file and inserts it after the current line. |
| :w <i>filename</i> | Writes a buffer to the file. |
| :wq | Saves changes and exits. |
| Search Text | |
| / <i>string</i> | Searches forward for a string. |
| ? <i>string</i> | Searches backward for a string. |
| Miscellaneous | |
| u | Undoes the last command. |
| Esc | Ends input mode and enters visual command mode. |
| U | Undoes recent changes to the current line. |

Book III

Networking

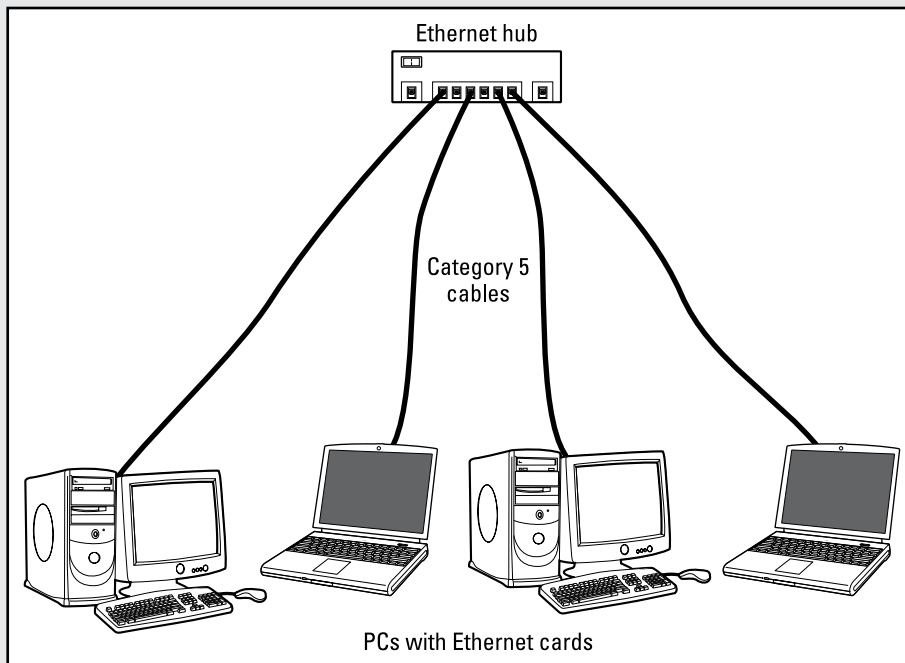

Visit www.dummies.com/extras/linuxaio for great Dummies content online.

Contents at a Glance

| | |
|---|------------|
| Chapter 1: Connecting to the Internet | 153 |
| Understanding the Internet..... | 153 |
| Deciding How to Connect to the Internet..... | 154 |
| Connecting with DSL..... | 156 |
| Connecting with a Cable Modem..... | 161 |
| Chapter 2: Setting Up a Local Area Network | 167 |
| Understanding TCP/IP..... | 167 |
| Setting Up an Ethernet LAN | 172 |
| Configuring TCP/IP Networking | 175 |
| Connecting Your LAN to the Internet..... | 177 |
| Chapter 3: Going Wireless | 179 |
| Understanding Wireless Ethernet Networks | 179 |
| Setting Up Wireless Hardware..... | 183 |
| Configuring the Wireless Access Point | 184 |
| Configuring Wireless Networking..... | 185 |
| Chapter 4: Managing the Network | 189 |
| Discovering the TCP/IP Configuration Files | 189 |
| Checking Out TCP/IP Networks..... | 193 |
| Configuring Networks at Boot Time..... | 199 |

Chapter 1: Connecting to the Internet

In This Chapter

- ✓ **Understanding the Internet**
- ✓ **Deciding how to connect to the Internet**
- ✓ **Connecting to the Internet with DSL**
- ✓ **Connecting to the Internet with a cable modem**

Given the prevalence and popularity of the Internet, it's a safe bet to assume that you want to connect your Linux system to the Internet. In this chapter, I show you how to connect to the Internet in several ways — depending on whether you have a DSL or cable modem. There are still some who connect using a dial-up network connection, but those are few and far between these days; most users aren't comfortable with the slower performance of a dial-up connection.

Two of the options for connecting to the Internet — DSL and cable modem — involve attaching a special modem to an Ethernet card on your Linux system. In these cases, you have to set up Ethernet networking on your Linux system. (I explain networking in Chapter 2 of this minibook.) If your machine is nothing more than a client on a network that it connects to via a mobile/Wi-Fi connection, and not needing its own dedicated connection, then thinks couldn't be easier and you'll simply want to skim what is here before moving on to subsequent chapters.

Understanding the Internet

How you view the Internet depends on your perspective. Most people see the Internet in terms of the services they use. For example, as a user, you might think of the Internet as an information-exchange medium with features such as

- ◆ **E-mail:** Send e-mail to any other user on the Internet, using addresses such as `mom@home.net`.
- ◆ **Web:** Download and view documents from millions of servers throughout the Internet.
- ◆ **Newsgroups:** Read newsgroups and post news items to newsgroups with names such as `comp.os.linux.networking` or `comp.os.linux.setup`.

- ◆ **Information sharing:** Download software, music files, videos, and so on. Reciprocally, you may provide files that users on other systems can download.
- ◆ **Remote access:** Log in to another computer on the Internet, assuming that you have access to that remote computer.

The techies say that the Internet is a worldwide *network of networks*. The term *internet* (without capitalization) is a shortened form of *internetworking* — the interconnection of networks. The Internet Protocol (IP) was designed with the idea of connecting many separate networks.



In terms of physical connections, the Internet is similar to a network of highways and roads. This similarity is what has prompted the popular press to dub the Internet “the Information Superhighway.” Just as the network of highways and roads includes some interstate highways, many state roads, and many more residential streets, the Internet has some very high-capacity networks (for example, a 10-Gbps backbone can handle 10 billion bits per second) and a large number of lower-capacity networks ranging from 56 Kbps dial-up connections to 45-Mbps T3 links. (*Kbps* is thousand-bits-per-second, and *Mbps* is million-bits-per-second.) The high-capacity network is the backbone of the Internet.

In terms of management, the Internet isn’t run by a single organization, nor is it managed by any central computer. You can view the physical Internet as a *network of networks* managed collectively by thousands of cooperating organizations. Yes, a collection of networks managed by *thousands* of organizations — sounds amazing, but it works!

Deciding How to Connect to the Internet

So you want to connect your Linux workstation to the Internet, but you don’t know how? Let me count the ways. Nowadays you have three popular options for connecting homes and small offices to the Internet (huge corporations and governments have many other ways to connect):

- ◆ **Digital Subscriber Line (DSL):** Your local telephone company, as well as other telecommunications companies, may offer DSL. DSL provides a way to send high-speed digital data over a regular phone line. Typically, DSL offers data transfer rates of between 128 Kbps and 3.0 Mbps (usually, the higher the speed, the more you pay). You can often download from the Internet at much higher rates than when you send data from your PC to the Internet (*upload*). One caveat with DSL is that your home must be between 15,000 and 20,000 feet from your local central office (the DSL provider’s facility where your phone lines end up). The distance limitation varies from provider to provider. In the United States, you can check out the distance limits for many providers at www.dslreports.com/distance.

- ◆ **Cable modem:** If the cable television company in your area offers Internet access over cable, you can use that service to hook up your Linux system to the Internet. Typically, cable modems offer higher data-transfer rates than DSL — for about the same cost. Downloading data from the Internet via cable modem is much faster than sending data from your PC to the Internet. You can expect routine download speeds of 12 Mbps and upload speeds of around 2 Mbps, but sometimes you may get even higher speeds than these.

DSL and cable modem services connect you to the Internet and also act as your Internet service provider (ISP). In addition to improved speed, what you're paying for is an IP address and your e-mail accounts. Table 1-1 summarizes these options and compares/contrasts them to the dial-up connectivity you want to avoid wherever possible. You can consult that table and select the type of connection that's available to you and that best suits your needs.

| <i>Feature</i> | <i>Dial-up</i> | <i>DSL</i> | <i>Cable</i> |
|------------------------|--|---|---|
| Equipment | Modem | DSL modem, Ethernet card | Cable modem, Ethernet card |
| Also requires | Phone service and an Internet service provider (ISP) | Phone service and location within 15,000 to 20,000 feet of central office | Cable TV connection |
| Connection type | Dial to connect | Always on, dedicated | Always on, shared |
| Typical speed | 56 Kbps maximum | 1.5 Mbps download, 128 Kbps upload | 12 Mbps download, 2 Mbps upload (higher speeds cost more) |



Besides the three options shown in Table 1-1, a few other less common options may be available to you. These include fiber-to-the-home (FTTH), broadband over power lines (BPL), fixed wireless broadband (called FWB or WiMAX), and satellite Internet access (for example, DIRECWAY and StarBand). If you have one or more of these options available in your geographic area and you want to use one of them for Internet access, follow the specific service provider's instructions for setting up the Internet connection. Typically, satellite Internet access is available across large geographical regions (even places that don't have phone or cable), but the initial equipment cost and monthly fees are higher than for DSL and cable.

Connecting with DSL

DSL stands for Digital Subscriber Line. DSL uses your existing phone line to send digital data in addition to the normal analog voice signals (*analog* means continuously varying, whereas digital data is represented by 1s and 0s). The phone line goes from your home to a central office, where the line connects to the DSL provider's network. By the way, the connection from your home to the central office is called the *local loop*.

When you sign up for DSL service, the DSL provider hooks up your phone line to some special equipment at the central office. That equipment can separate the digital data from voice. From then on, your phone line can carry digital data that is then directly sent to an Internet connection at the central office.

How DSL works

A special box called a *DSL modem* takes care of sending digital data from your PC to the DSL provider's central office over your phone line. Your PC can connect to the Internet with the same phone line that you use for your normal telephone calls — you can make voice calls even as the line is being used for DSL. Figure 1-1 shows a typical DSL connection to the Internet.

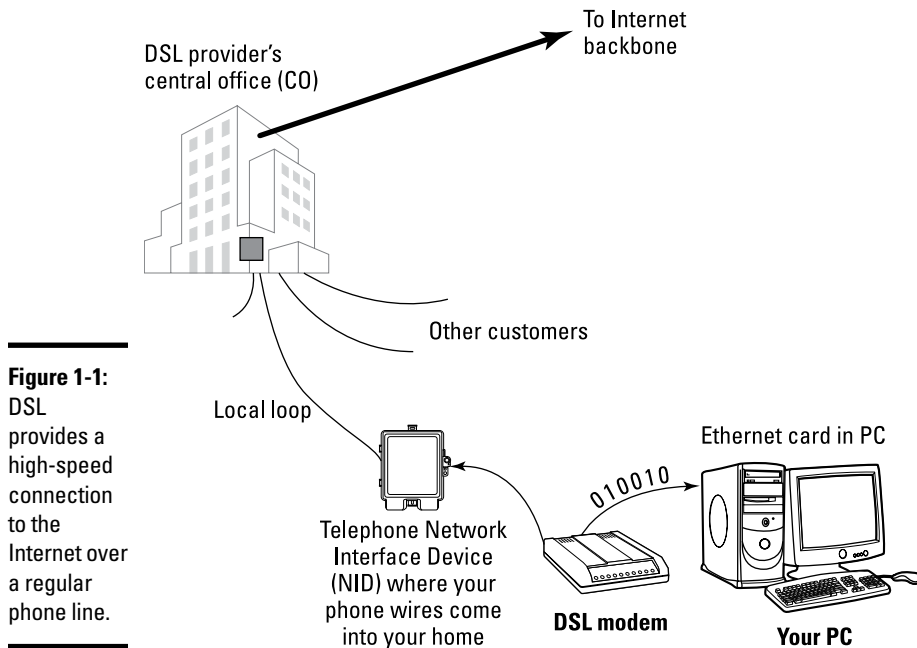

Figure 1-1: DSL provides a high-speed connection to the Internet over a regular phone line.

Your PC talks to the DSL modem through an Ethernet connection, which means that you need an Ethernet card in your Linux system.

Your PC sends digital data over the Ethernet connection to the DSL modem. The DSL modem sends the digital data at different frequencies than those used by the analog voice signals. The voice signals occupy a small portion of all the frequencies that the phone line can carry. DSL uses the higher frequencies to transfer digital data, so both voice and data can travel on the same phone line.



DSL alphabet soup: ADSL, IDSL, SDSL

I have been using the term *DSL* as if there were only one kind of DSL, but DSL has three variants, each with different features. Take a look:

- ◆ **ADSL:** *Asymmetric DSL* is the most common form of DSL and has much higher download speeds (from the Internet to your PC) than upload speeds (from your PC to the Internet). ADSL can have download speeds of up to 8 Mbps and upload speeds of up to 1 Mbps. ADSL works best when your location is within about two to two-and-a-half miles (12,000 feet) of the central office. ADSL service is priced according to the download and upload speeds you want. A popular form of ADSL, called G.lite, has a maximum download speed of 1.5 Mbps and a maximum upload speed of 512 Kbps.
- ◆ **IDSL:** Short for *ISDN DSL* (ISDN is an older technology called *Integrated Services Digital Network*), IDSL is a special type of DSL that works at distances of up to five miles between your phone and the central office. The downside is that IDSL averages *downstream* (from the Internet to your PC) and *upstream* (from your PC to the Internet) speeds of around 144 Kbps — comparable to what an old-fashioned modem could do over a dial-up connection.
- ◆ **SDSL:** Symmetric DSL provides equal download and upload speeds of up to 2.0 Mbps. SDSL is priced according to the speed you want, with the higher speeds costing more. The closer your location is to the central office, the faster the connection you can get.



DSL (and cable modem) speeds are typically specified by two numbers separated by a slash, such as 1500/384. The numbers refer to data-transfer speeds in kilobits per second (that is, thousands of bits per second, abbreviated Kbps). The first number is the download speed; the second, the upload. Thus, 1500/384 means you can expect to download from the Internet at a maximum rate of 1,500 Kbps (or 1.5 Mbps) and upload to the Internet at 384 Kbps. If your phone line's condition isn't perfect, you may not get these maximum rates — both ADSL and SDSL adjust the speeds to suit existing line conditions.

The price of DSL service depends on which variant — ADSL, IDSL, or SDSL — you select. For most home users, the primary choice is ADSL (or, more accurately, the G.lite form of ADSL) with transfer speed ratings of up to 9000/640.

Typical DSL setup

To get DSL for your home or business, you have to contact a DSL provider. You can find many other DSL providers in addition to your phone company. No matter who provides the DSL service, some work has to be done at the central office — the place where your phone lines connect to the rest of the phone network. The work involves connecting your phone line to equipment that can work with the DSL modem at your home or office. The central office equipment and the DSL modem at your location can then do whatever magic is needed to send and receive digital data over your phone line.

The distance between your home and the central office — the *loop length* — is a factor in DSL's performance. Unfortunately, the phone line can reliably carry the DSL signals over only a limited distance — typically three miles or less, which means that you can get DSL service only if your home (or office) is located within about three miles of the central office. Contact your DSL provider to verify. You may be able to check this availability on the web. Try typing into Google (www.google.com) the words **DSL availability** and then your provider's name. The search results will probably include a website where you can type in your phone number to find out if DSL is available for your home or office.

If DSL is available, you can look for the types of service — ADSL versus SDSL — and the pricing. The price depends on what download and upload speeds you want. Sometimes phone companies offer a simple residential DSL (basically the G.lite form of ADSL) with a 1500/128 speed rating — meaning you can download at up to 1,500 Kbps and upload at 128 Kbps. Of course, these are the *maximums*, and your mileage may vary.

After selecting the type of DSL service and provider you want, you can place an order and have the provider install the necessary equipment at your home or office. Figure 1-2 shows a sample connection diagram for typical residential DSL service.

Here are some key points to note in Figure 1-2:

- ◆ Connect your DSL modem's data connection to the phone jack on a wall plate.
- ◆ Connect the DSL modem's Ethernet connection to the Ethernet card on your PC.

- ◆ When you connect other telephones or fax machines on the same phone line, install a microfilter between the wall plate and each of these devices.

Because the same phone line carries both voice signals and DSL data, you need the microfilter to protect the DSL data from possible interference. You can buy these filters at electronics stores or from the DSL provider.

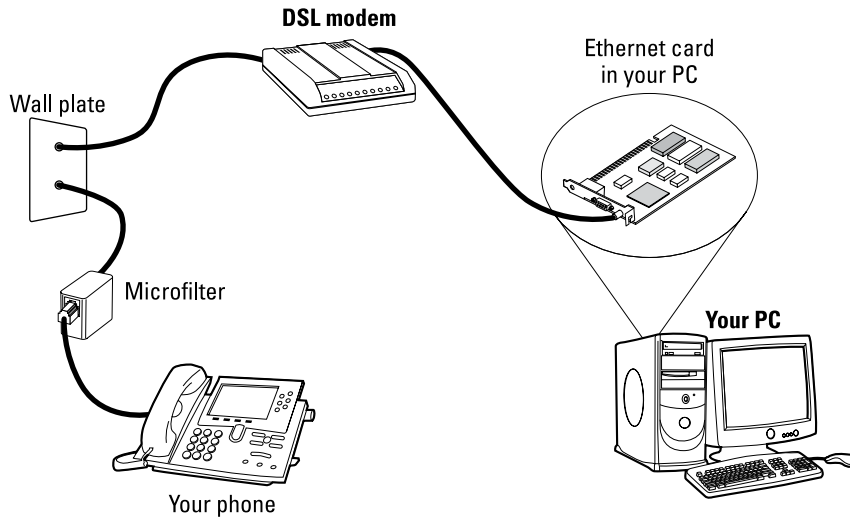

Figure 1-2: You can connect a PC's Ethernet card directly to the DSL modem.



When you connect your Linux PC to the Internet using DSL, the connection is always on, which means a greater potential for outsiders to break into the PC.

You can protect your Linux system from intruders and, as a bonus, share the high-speed connection with other PCs in a local area network (LAN) by using a router that can perform Network Address Translation (NAT). A NAT router translates multiple private Internet Protocol (IP) addresses from an internal LAN into a single public IP address, which allows all the internal PCs to access the Internet. The NAT router acts as a gateway between your LAN and the Internet, and it isolates your LAN from the Internet — this makes it harder for intruders to reach the systems on your LAN.

If you also want to set up a local area network, you need an Ethernet hub or switch to connect the other PCs to the network. Figure 1-3 shows a typical setup that connects a LAN to the Internet through a NAT router and a DSL modem.

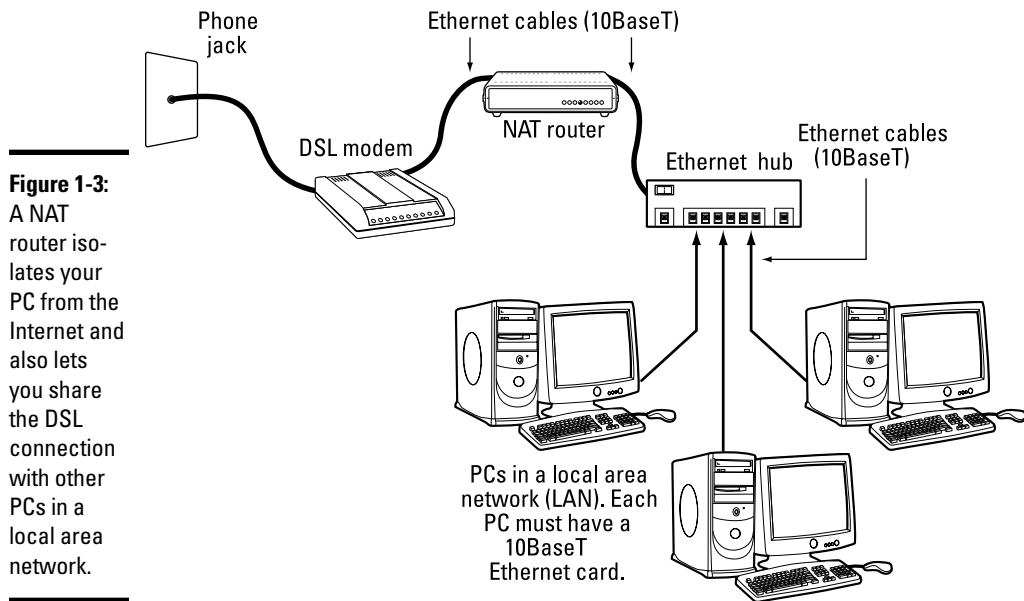

Figure 1-3: A NAT router isolates your PC from the Internet and also lets you share the DSL connection with other PCs in a local area network.

Here are the points to note when setting up a connection like the one shown in Figure 1-3:

- ◆ You need a NAT router with two 100BaseT or 10BaseT Ethernet ports (the 100BaseT and 10BaseT ports look like large phone jacks; they're also known as *RJ-45 jacks*). Typically, one Ethernet port is labeled *Internet* (or *External* or *WAN*, for wide area network), and the other one is labeled *Local* or *LAN* (for local area network).
- ◆ You also need an Ethernet hub/switch. For a small home network, you can buy a 4- or 8-port Ethernet hub. Basically, you want a hub with as many ports as the number of PCs you intend to connect to your local area network. For a business, you'll want to replace the hub with a switch.
- ◆ Connect the Ethernet port of the DSL modem to the Internet port of the NAT router, using a 100BaseT Ethernet cable. (These look like phone wires with bigger RJ-45 jacks and are often labeled *Category 5* or *Cat 5 wire*.)
- ◆ Connect the Local Ethernet port of the NAT router to one of the ports on the Ethernet hub/switch, using a 100BaseT Ethernet cable.
- ◆ Now connect each of the PCs to the Ethernet hub/switch. (To do so, you must first have an Ethernet card installed and configured in each PC.)



You can also buy a NAT router with a built-in 4-port or 8-port Ethernet hub. With such a combined router and hub, you need only one box to set up a LAN and connect it to the Internet via a DSL modem. These boxes are typically sold under the name *Cable/DSL router* because they work with both DSL and a cable modem.

Consult Chapter 2 of this minibook for information on how to configure networking on the Linux system so that your system can access the Internet.



DSL providers typically use a protocol known as *PPP over Ethernet (PPPoE)* to establish a connection between your PC and the equipment at the provider's central office. PPPoE requires you to provide a username and password to establish the network connection over Ethernet. To set up your system for a PPPoE DSL connection, all you have to do is run a utility program that configures the system for PPPoE. You can find the utility by searching in the main menu in the GUI desktop.



In Ubuntu, you can set up a PPPoE DSL connection by choosing System⇨Administration⇨Network Tools, clicking the modem connection, and choosing Properties. Then go through the successive screens and provide the requested account information, such as username and password.

Connecting with a Cable Modem

Cable TV companies also offer high-speed Internet access over the same coaxial cable that carries television signals to your home. After the cable company installs the necessary equipment at its facility to send and receive digital data over the coaxial cables, customers can sign up for cable Internet service. You can then get high-speed Internet access over the same line that delivers cable TV signals to your home.

How a cable modem works

A box called a *cable modem* is at the heart of Internet access over the cable TV network. (See Figure 1-4.) The cable modem takes digital data from your PC's Ethernet card and puts it in an unused block of frequency. (Think of this frequency as another TV channel, but instead of pictures and sound, this channel carries digital data.)

The cable modem places *upstream data* — data that's being sent from your PC to the Internet — in a different channel from that of the *downstream data* that's coming from the Internet to your PC. By design, the speed of downstream data transfers is much higher than that of upstream transfers. The assumption is that people download far more stuff from the Internet than they upload (which is probably true for most of us).

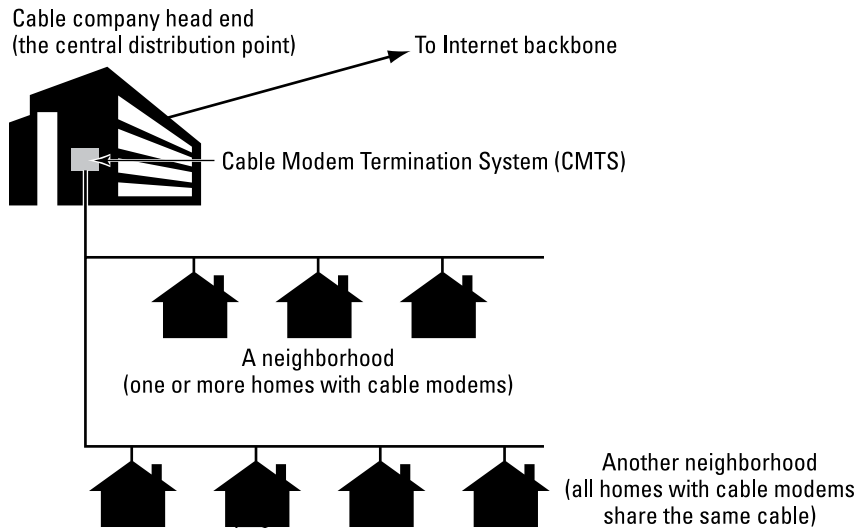
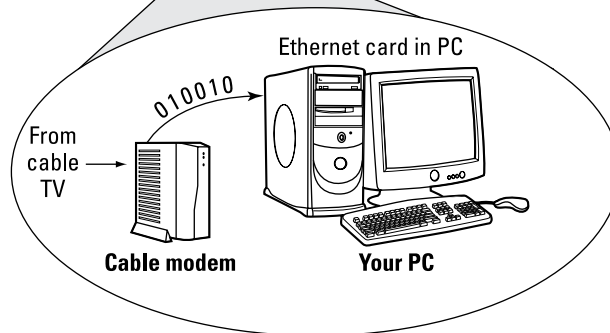

Figure 1-4: Cable modems provide high-speed Internet access over the cable TV network.



The coaxial cable that carries all those hundreds of cable TV channels to your home is a very capable signal carrier. In particular, the coaxial cable can carry signals covering a huge range of frequencies — hundreds of megahertz (MHz). Each TV channel requires 6 MHz — and the coaxial cable can carry hundreds of such channels. The cable modem places the upstream data in a small frequency band and expects to receive the downstream data in another frequency band.



At the other end of your cable connection to the Internet is the *Cable Modem Termination System* (CMTS) — also known as the *head end* — that your cable company installs at its central facility. (Refer to Figure 1-4.) The CMTS connects the cable TV network to the Internet. It also extracts the upstream

digital data sent by your cable modem (and by those of your neighbors as well) and sends it to the Internet. The CMTS also puts digital data into the upstream channels so that your cable modem can extract that data and provide it to your PC via the Ethernet card.

Cable modems can receive downstream data at the rate of about 50 Mbps and send data upstream at around 10 Mbps. However, all the cable modems in a neighborhood share the same downstream capacity. Each cable modem filters out — separates — the data it needs from the stream of data that the CMTS sends out. Cable modems follow a modem standard called DOCSIS, which stands for Data Over Cable Service Interface. You can buy any DOCSIS-compliant modem and use it with your cable Internet service; all you have to do is call the people at the cable company and give them the modem's identifying information so that the CMTS can recognize and initialize the modem.



In practice, with a cable modem, you'll most likely get downstream transfer rates of around 12 Mbps and upstream rates of 2 Mbps. These are maximum rates; your actual transfer rate is typically lower, depending on how many people in your neighborhood are using cable modems at the same time.



If you want to check your downstream transfer speed, go to <http://bandwidthplace.com/speedtest> and click the link to start the test. For my cable modem connection, for example, a recent test reported a downstream transfer rate of about 2.2 Mbps, but at other times the rate has been as high as 5.2 Mbps.

Typical cable modem setup

To set up cable modem access, your cable TV provider must offer high-speed Internet access. If the service is available, you can call to sign up. The cable companies often have promotional offers, such as no installation fee or a reduced rate for three months. If you're lucky, a local cable company may have a promotion going on just when you want to sign up.

The installation is typically performed by a technician, who splits your incoming cable into two — one side goes to the TV and the other to the cable modem. The technician provides information about the cable modem to the cable company's head end for setup at its end. When that work is completed, you can plug in your PC's Ethernet card to the cable modem, and you'll be all set to enjoy high-speed Internet access. Figure 1-5 shows a typical cable modem hookup.

The cable modem connects to an Ethernet card in your PC. If you don't have an Ethernet card in your PC, the cable company technician often provides one.

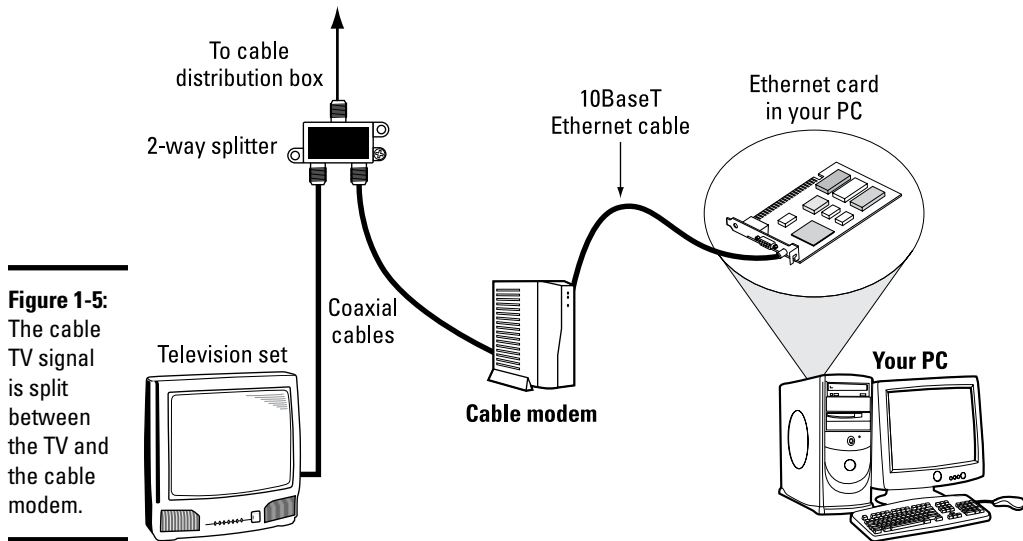

Figure 1-5: The cable TV signal is split between the TV and the cable modem.

Here are some key points to note about the cable modem setup in Figure 1-5:

- ◆ Split the incoming cable TV signal into two parts by using a two-way splitter. (The cable company technician installs the splitter.)
- ◆ The two-way splitter needs to be rated for 1 GHz; otherwise it may not let the frequencies that contain the downstream data from the Internet pass through.
- ◆ Connect one of the video outputs from the splitter to your cable modem's F-type video connector, using a coaxial cable.
- ◆ Connect the cable modem's 100BaseT Ethernet connection to the Ethernet card on your PC.
- ◆ Connect your TV to the other video output from the two-way splitter.



When you use cable modem to connect your Linux PC directly to the Internet, the connection is always on, so you have more of a chance that someone may try to break into the PC. Linux includes the `iptables` packet filtering capability, which you may want to use to protect your PC from unwanted Internet connections.



To isolate your Linux PC or local area network from the public Internet, you may want to add a NAT router between your PC and the cable modem. One of the NAT router's network interfaces connects to the Internet, and the other connects to your LAN; the router then acts as a gateway between your LAN and the Internet. As a bonus, you can even share a cable modem connection with all the PCs in your own local area network (LAN) by adding an Ethernet hub. Better yet, buy a combination NAT router and hub so you have only one box to do the entire job.



Boxes that combine NAT router and hub are typically sold under the name *cable/DSL router* because they work with both DSL and cable modem.

The NAT router translates private IP addresses into a public IP address. When connected through a NAT router, any PC in the internal LAN can access the Internet as if it had its own unique IP address. As a result, you can share a single Internet connection among many PCs — an ideal solution for a family of Net surfers!

Figure 1-6 shows a typical setup with a cable modem connection being shared by a number of PCs in a LAN.

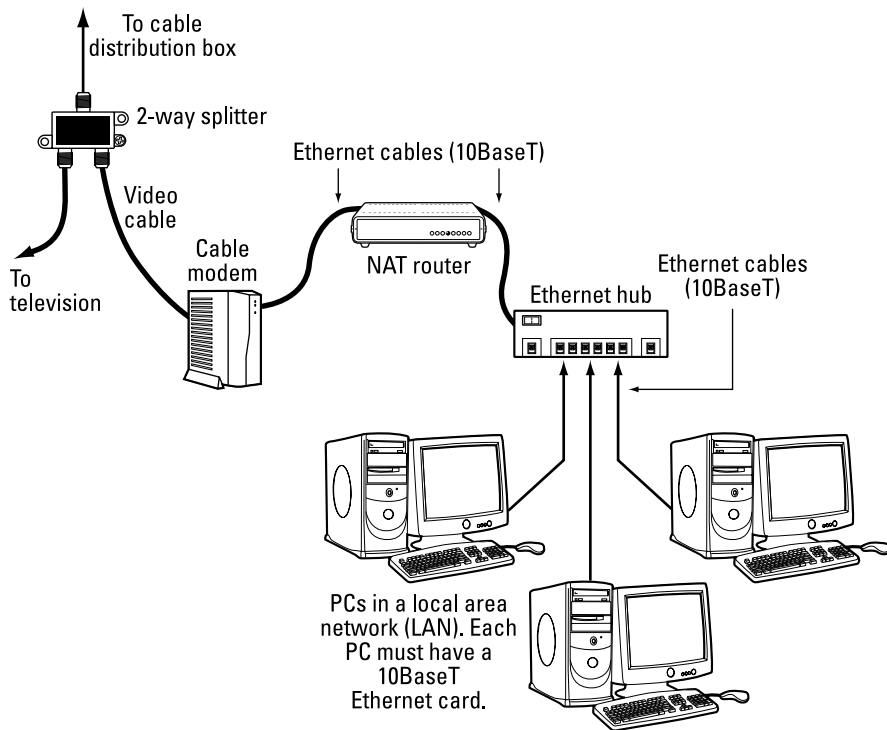

Figure 1-6: A NAT router isolates your PC from the Internet and also lets you share the cable modem connection with other PCs in a LAN.

Here are the points to note when setting up a connection like the one shown in Figure 1-6:

- ◆ You need a cable/DSL NAT router with two 100BaseT Ethernet ports (the 100BaseT port — also known as an *RJ-45 jack*, which looks like a large phone jack). Typically, one Ethernet port is labeled *Internet* (or *External* or *WAN*, for wide area network), and the other one is labeled *Local*.
- ◆ If you plan to set up a LAN, you also need an Ethernet hub/switch. For a small home network, you can buy a 4- or 8-port Ethernet hub. Basically,

you want a hub with as many ports as the number of PCs you intend to connect to your local area network.

- ◆ Consider buying a single box that acts as both a NAT router and a hub with a number of Ethernet ports.
- ◆ Connect the video cable to the video input port of the cable modem.
- ◆ Connect the Ethernet port of the cable modem to the Internet port of the NAT router using a 100BaseT Ethernet cable. (The cable looks like a phone wire except that the Ethernet cable has bigger RJ-45 jacks and is often labeled *Category 5* or *Cat 5 wire*.)
- ◆ Connect the Local Ethernet port of the NAT router to one of the ports on the Ethernet hub, using a 100BaseT Ethernet cable.
- ◆ Now connect each of the PCs to the Ethernet hub. Each PC must have an Ethernet card.

In Chapter 2 of this minibook, I explain how to configure the PCs in a LAN so that they can all access the Internet through the router.

Chapter 2: Setting Up a Local Area Network

In This Chapter

- ✓ Understanding TCP/IP networks
- ✓ Setting up an Ethernet local area network
- ✓ Discovering how to configure TCP/IP networking
- ✓ Connecting a LAN to the Internet

Linux comes with built-in support for Transmission Control Protocol/Internet Protocol (TCP/IP) networking, as do most modern operating systems from Windows to Mac OS. You can have TCP/IP networking over many different physical interfaces, such as Ethernet cards, serial ports, and parallel ports.

Typically, you use an Ethernet network for your local area network (LAN) — at your office or even your home (if you happen to have two or more systems at home) — with wireless (the subject of the next chapter) gaining in popularity in most locations.

This chapter describes how to set up an Ethernet network. Even if you have a single PC, you may need to set up an Ethernet network interface so that you can connect to high-speed Internet access (that uses a DSL or cable modem somewhere along the way.)

Understanding TCP/IP

You can understand TCP/IP networking best if you think in terms of a four-layer model, with each layer responsible for performing a particular task. The layered model describes the flow of data between the physical connection to the network and the end-user application. Figure 2-1 shows the four-layer network model for TCP/IP.

In this four-layer model, information always moves from one layer to the next. For example, when an application sends data to another application, the data goes through the layers in this order: application↔transport↔network↔physical. At the receiving end, the data goes up from physical↔network↔transport↔application.

Figure 2-1:
You can understand TCP/IP using the four-layer network model.

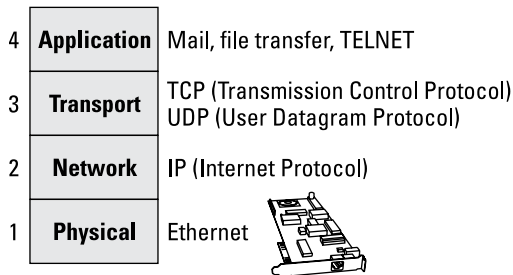

Each layer has its own set of *protocols* — conventions — for handling and formatting the data. If you think of sending data as something akin to sending letters through the postal service, a typical protocol is a preferred sequence of actions for a task, such as addressing an envelope (first the name, then the street address, and then the city, state, and zip or other postal code).



These four layers, depending on what reference you look at, might have different names. For example, if you look at the old DOD model, the transport is called host-to-host, network is called internetwork or Internet, application is process/application, and physical is network access.

Here's what each of the four layers does, top to bottom:

- ◆ **Application:** Runs the applications that users use, such as e-mail readers, file transfers, and web browsers. Application-level protocols are Simple Mail Transfer Protocol (SMTP) and Post Office Protocol (POP) for e-mail, HyperText Transfer Protocol (HTTP) for the web, and File Transfer Protocol (FTP) for file transfers. Application-level protocols also have a *port number* that you can think of as an identifier for a specific application. For example, port 80 is associated with HTTP or the web server.
- ◆ **Transport:** Sends data from one application to another. The two most important protocols in this layer are Transmission Control Protocol (TCP) and User Datagram Protocol (UDP). TCP guarantees delivery of data; UDP just sends the data without ensuring that it actually reaches the destination.
- ◆ **Network:** This layer is responsible for getting data packets from one network to another. If the networks are far apart, the data packets are routed from one network to the next until they reach their destination. The primary protocol in this layer is the Internet Protocol (IP).
- ◆ **Physical:** Refers to the physical networking hardware (such as an Ethernet card or token ring card) that carries the data packets in a network.

TCP/IP and the Internet

TCP/IP has become the protocol of choice on the Internet — *the network of networks* that evolved from ARPANET. The U.S. Government's Advanced Research Projects Agency (ARPA) initiated research in the 1970s on a new way of sending information, using packets of data sent over a network. The result was ARPANET: a national network of linked computers. Subsequently, ARPA acquired a Defense prefix and became DARPA. Under

the auspices of DARPA, the TCP/IP protocols emerged as a popular collection of protocols for *internetworking* — communication among networks.

TCP/IP has flourished because the protocol is *open*. That means the technical descriptions of the protocol appear in public documents, so anyone can implement TCP/IP on specific hardware and software.

The beauty of the layered model is that each layer takes care of only its specific task, leaving the rest to the other layers. The layers can mix and match — you can have TCP/IP network over any type of physical network medium, from Ethernet to radio waves (in a wireless network). The software is modular as well; each layer can be implemented in different modules. For example, typically the transport and network layers already exist as part of the operating system, and any application can make use of these layers.

TCP/IP also made great inroads because stable, working software was available. Instead of a paper description of network architecture and protocols, the TCP/IP protocols started out as working software — and who can argue with what's already working? These days, as a result, TCP/IP rules the Internet.

IP addresses

When you have many computers on a network, you need a way to identify each one uniquely. In TCP/IP networking, the address of a computer is the IP address. Because TCP/IP deals with internetworking, the address is based on the concepts of a network address and a host address. You may think of the idea of a network address and a host address as having to provide two addresses to identify a computer uniquely:

- ◆ **Network address** indicates the network on which the computer is located.
- ◆ **Host address** indicates a specific computer on that network.

The network and host addresses together constitute an *IP address*, and it's a 4-byte (32-bit) value. The convention is to write each byte as a decimal value and to put a dot (.) after each number. Thus you see network addresses such as 132.250.112.52. This way of writing IP addresses is known as *dotted-decimal* or *dotted-quad* notation.



What about IP (IPv6)?

When the 4-byte IP address was created, the number of available addresses seemed adequate. Now, however, the 4-byte addresses are running out. The Internet Engineering Task Force (IETF) recognized the potential for running out of IP addresses in 1991 and began work on the next-generation IP addressing scheme. They called it IPng (for Internet Protocol Next Generation) and intended for it to eventually replace the old 4-byte addressing scheme (called IPv4, for IP version 4).

Several alternative addressing schemes for IPng were proposed and debated. The final contender, with a 128-bit (16-byte) address, was dubbed IPv6 (for IP version 6). On September 18, 1995, the IETF declared the core set of IPv6 addressing protocols to be an IETF Proposed Standard. By now, there are many RFCs (Request for Comments) dealing with various aspects of IPv6, from IPv6 over PPP for the transmission of IPv6 packets over Ethernet.

IPv6 is designed to be an evolutionary step from IPv4. The proposed standard provides direct interoperability between hosts using the older IPv4 addresses and any new IPv6 hosts. The idea is that users can upgrade their systems to use IPv6 when they want and that network operators are free to upgrade their network hardware to use IPv6 without affecting current users of IPv4. Sample implementations of IPv6 are being developed for many operating systems, including Linux. For more information about IPv6 in Linux, consult the Linux IPv6 HOWTO at www.tldp.org/HOWTO/Linux+IPv6-HOWTO. For information about IPv6 in general, visit the IPv6 home page at www.ipv6.org.

The IPv6 128-bit addressing scheme allows for a total of 2^{128} or 340,282,366,920,938,463,374,607,431,768,211,456 theoretically assignable addresses. That should last us for a while!



In decimal notation, a byte (which has 8 bits) can have a value between 0 and 255. Thus a valid IP address can use only the numbers between 0 and 255 in the dotted-decimal notation.

Internet services and port numbers

The TCP/IP protocol suite has become the lingua franca of the Internet because many standard services are available on any system that supports TCP/IP.

These services make the Internet tick by facilitating the transfer of mail, news, and web pages. These services go by well-known names such as the following:

- ◆ **DHCP** (Dynamic Host Configuration Protocol) is for dynamically configuring TCP/IP network parameters on a computer. DHCP is primarily used to assign dynamic IP addresses and other networking information (such as name server, default gateway, and domain names) needed to configure TCP/IP networks. The DHCP server listens on port 67.
- ◆ **FTP** (File Transfer Protocol) is used to transfer files between computers on the Internet. FTP uses two ports — data is transferred on port 20, and control information is exchanged on port 21.

- ◆ **DNS** (Domain Name System) is used to translate domain names into IP addresses. This service runs on port 53.
- ◆ **HTTP** (HyperText Transfer Protocol) is a protocol for sending documents from one system to another. HTTP is the underlying protocol of the World Wide Web. By default, the web server and client communicate on port 80. When combined with SSL/TLS, the protocol becomes HTTPS and the port changes to 443.
- ◆ **SMTP** (Simple Mail Transfer Protocol) is for exchanging e-mail messages between systems. SMTP uses port 25 for information exchange.
- ◆ **POP3** (Post Office Protocol version 3) is used by the client to receive mail and it uses port 110. When combined with SSL/TLS for security, the port changes to 995.
- ◆ **IMAP** (Internet Message Access Protocol) can also be used by clients to interact with mail (in place of POP3) and it uses port 143. When combined with SSL/TLS for security, the port changes to 993.
- ◆ **NNTP** (Network News Transfer Protocol) is for distribution of news articles in a store-and-forward fashion across the Internet. NNTP uses port 119.
- ◆ **NetBIOS** is used by Windows for networking and it utilizes a number of ports, the most common of which is 139 which is used for the session.
- ◆ **SSH** (Secure Shell) is a protocol for secure remote login and other secure network services over an insecure network. SSH uses port 22.
- ◆ **TELNET** is used when a user on one system logs in to another system on the Internet. (The user must provide a valid user ID and password to log in to the remote system.) TELNET uses port 23 by default, but the TELNET client can connect to any port.
- ◆ **SNMP** (Simple Network Management Protocol) is for managing all types of network devices on the Internet. Like FTP, SNMP uses two ports: 161 and 162.
- ◆ **Rendezvous Directory Service** (used by Cisco) uses port 465.
- ◆ **TFTP** (Trivial File Transfer Protocol) is for transferring files from one system to another. (It's typically used by X terminals and diskless workstations to download boot files from another host on the network.) TFTP data transfer takes place on port 69.
- ◆ **NFS** (Network File System) is for sharing files among computers. NFS uses Sun's Remote Procedure Call (RPC) facility, which exchanges information through port 111.

A well-known port is associated with each of these services. The TCP protocol uses each such port to locate a service on any system. (A *server process* — a special computer program running on a system — provides each service.)

Setting Up an Ethernet LAN

Ethernet is a standard way to move packets of data between two or more computers connected to a single hub, router, or switch. (You can create larger networks by connecting multiple Ethernet segments with gateways.) To set up an Ethernet LAN, you need an Ethernet card for each PC. Linux supports a wide variety of Ethernet cards for the PC.

Ethernet is a good choice for the physical data-transport mechanism for the following reasons:

- ◆ Ethernet is a proven technology that has been in use since the early 1980s.
- ◆ Ethernet provides good data-transfer rates: typically 10 million bits per second (10 Mbps), although 100-Mbps Ethernet and Gigabit Ethernet (1,000 Mbps) are now common.
- ◆ Ethernet hardware is often built into the PC or can be installed at a relatively low cost. (PC Ethernet cards cost about \$10–20.)
- ◆ With wireless Ethernet, you can easily connect laptop PCs to your Ethernet LAN without having to run wires all over the place. (Go to Chapter 3 of this minibook for more information on wireless Ethernet.)

How Ethernet works

So what makes Ethernet tick? In essence, it's the same thing that makes any conversation work: listening and taking turns.



In an Ethernet network, all systems in a segment are connected to the same wire. A protocol is used for sending and receiving data because only one data packet can exist on the single wire at any time. An Ethernet LAN uses a data-transmission protocol known as *Carrier-Sense Multiple Access/Collision Detection* (CSMA/CD) to share the single transmission cable among all the computers. Ethernet cards in the computers follow the CSMA/CD protocol to transmit and receive Ethernet packets.

The idea behind the CSMA/CD protocol is similar to the way in which you have a conversation at a party. You listen for a pause (that's sensing the carrier) and talk when no one else is speaking. If you and another person begin talking at the same time, both of you realize the problem (that's collision detection) and pause for a moment; then one of you starts speaking again. As you know from experience, everything works out.

In an Ethernet LAN, each Ethernet card checks the cable for signals — that's the carrier-sense part. If the signal level is low, the Ethernet card sends its packets on the cable; the packet contains information about the sender and the intended recipient. All Ethernet cards on the LAN listen to the signal, and the recipient receives the packet. If two cards send out a packet simultaneously, the signal level in the cable rises above a threshold, and the cards

know a collision has occurred. (Two packets have been sent out at the same time.) Both cards wait for a random amount of time before sending their packets again.

Ethernet was invented in the early 1970s at the Xerox Palo Alto Research Center (PARC) by Robert M. Metcalfe. In the 1980s, Ethernet was standardized by the cooperative effort of three companies: Digital Equipment Corporation (DEC), Intel, and Xerox. Using the first initials of the company names, that Ethernet standard became known as the DIX standard. Later, the DIX standard was included in the 802-series standards developed by the Institute of Electrical and Electronics Engineers (IEEE). The final Ethernet specification is formally known as IEEE 802.3 CSMA/CD, but people continue to call it *Ethernet*.

Ethernet sends data in *packets* (discrete chunks also known as *frames*). You don't have to hassle much with the innards of Ethernet packets, except to note the 6-byte source and destination addresses. Each Ethernet controller has a unique 6-byte (48-bit) address at the physical layer; every packet must have one.

Ethernet cables

Any time you hear experts talking about Ethernet, you'll also hear some bewildering terms used for the cables that carry the data. Here's a quick rundown.



The original Ethernet standard used a thick coaxial cable, nearly half an inch in diameter. This wiring is called *thicknet*, *thickwire*, or just *thick Ethernet* although the IEEE 802.3 standard calls it *10Base5*. That designation means several things: The data-transmission rate is 10 megabits per second (10 Mbps); the transmission is *baseband* (which simply means that the cable's signal-carrying capacity is devoted to transmitting Ethernet packets only), and the total length of the cable can be no more than 500 meters. Thickwire was expensive, and the cable was rather unwieldy. Unless you're a technology history buff, you don't have to care one whit about 10Base5 cables.



Nowadays, several other forms of Ethernet cabling are more popular. An alternative to thick Ethernet cable is *thinwire*, or 10Base2, which uses a thin, flexible coaxial cable. A thinwire Ethernet segment can be, at most, 185 meters long. The other, more recent, alternative is Ethernet over unshielded twisted-pair cable (UTP), known as 10BaseT. More recent Ethernet cabling options that support higher transmission rates include 100BaseT4, 100BaseT2, and 100BaseTX for 100-Mbps Ethernet and 1000BaseT for Gigabit Ethernet. The Electronic Industries Association/Telecommunications Industries Association (EIA/TIA) defines the following five categories of shielded and unshielded twisted-pair cables:

- ◆ **Category 1 (Cat 1):** Traditional telephone cable.
- ◆ **Category 2 (Cat 2):** Cable certified for data transmissions up to 4 Mbps.

- ◆ **Category 3 (Cat 3):** Cable that can carry signals up to a frequency of 16 MHz. Cat 3 is the most common type of wiring in old corporate networks, and it normally contains four pairs of wire. Now considered obsolete.
- ◆ **Category 4 (Cat 4):** Cable that can carry signals up to a frequency of 20 MHz. Cat 4 wires aren't common. Now considered obsolete.
- ◆ **Category 5 (Cat 5):** Cable that can carry signals up to a frequency of 100 MHz. Cat 5 cables normally have four pairs of copper wire. Cat 5 UTP is the most popular cable used in new installations today. This category of cable is being superseded by Category 5e (enhanced Cat 5).
- ◆ **Category 5e (Cat 5e):** Similar to Cat 5 but with improved technical parameters, such as near-end cross talk and attenuation. Cat 5e cables support 10BaseT, 100BaseT4, 100BaseT2, and 100BaseTX and 1000BaseT Ethernet. Nowadays, Cat 5e is the minimum acceptable wiring.
- ◆ **Category 6 (Cat 6):** Similar to Cat 5e but capable of carrying signals up to a frequency of 250 MHz. Cat 6 cables can support all existing Ethernet standards and also support Gigabit Ethernet standard 1000BaseTX, which uses two pairs of wires in each direction (as opposed to all four pairs for 1000BaseT Ethernet over Cat 5e cables).

To set up a 10BaseT or 100BaseT Ethernet network, you need an *Ethernet hub* — a hardware box with RJ-45 jacks. (This type of jack looks like a big telephone jack.) You build the network by running twisted-pair wires (usually Category 5 cables) from each PC's Ethernet card to this hub. You can get a 4-port 10BaseT/100BaseT hub for about \$40. Figure 2-2 shows a typical small 10BaseT/100BaseT Ethernet LAN that you may set up at a small office or your home.

When you install any of the Linux distributions from this book's companion DVD-ROM on a PC connected with an Ethernet card, the Linux kernel automatically detects the Ethernet card and installs the appropriate drivers. The installer also lets you set up TCP/IP networking.



The Linux kernel loads the driver for the Ethernet card every time it boots. To verify that the Ethernet driver is loaded, type the following command in a terminal window:

```
dmesg | grep eth0
```

On one of my Linux PCs, I get the following output when I type that command:

```
eth0: RealTek RTL8139 at 0xf0e20000, 00:0c:76:f4:38:b3, IRQ 161
eth0: Identified 8139 chip type 'RTL-8101'
eth0: link up, 100Mbps, full-duplex, lpa 0x45E1
eth0: no IPv6 routers present
```

You should see something similar, showing the name of your Ethernet card and other related information.

Figure 2-2:
You can use an Ethernet hub to set up a 10BaseT or 100BaseT Ethernet LAN.

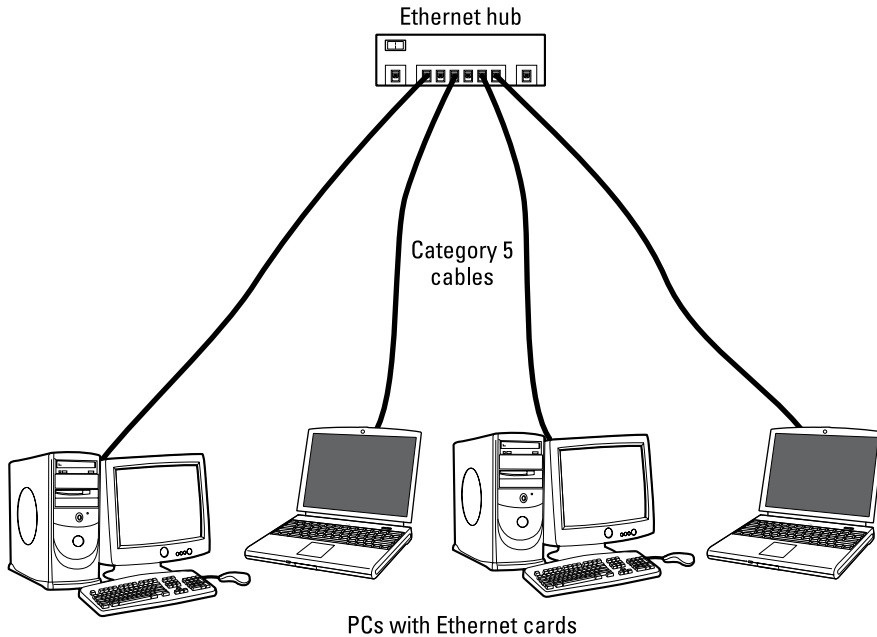

Configuring TCP/IP Networking

When you set up TCP/IP networking during Linux installation, the installation program prepares all appropriate configuration files using the information you provide. This means that you typically never have to manually configure the network. However, most Linux distributions come with GUI tools to configure the network devices, just in case something needs changing. For all distributions, the steps are similar.

In Ubuntu, for example, you can use the graphical network configuration tool. To start the GUI network configuration tool, choose System Settings → Network. The network configuration tool displays a dialog box, as shown in Figure 2-3. You can then configure your network through the choices that appear in the dialog box including settings for wired and wireless. The Airplane Mode toggle makes it convenient to temporarily disable the network.

Clicking the Options button displays a dialog box similar to the one shown in Figure 2-4. From here, you can configure everything from the security to the settings for the each protocol to use. On the General tab (shown in Figure 2-5), you can configure whether the connection will always try to be established — and whether all users can use the network.

Figure 2-3: Move through the dialog box choices to configure the connection.

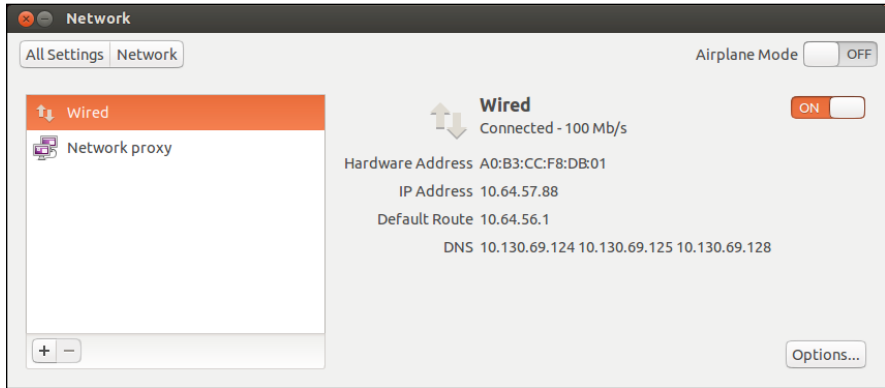
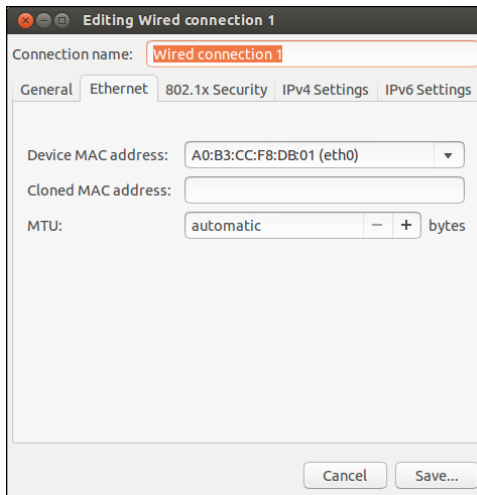
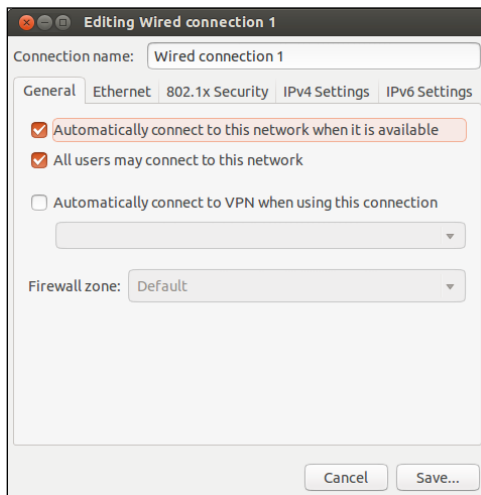

Figure 2-4: The Options button allows you to configure your connections.



In most cases, you can set the network card so it can automatically obtain an IP address (which is the case when the Ethernet card is connected to DSL or cable modem) by using DHCP. If your network doesn't have a DHCP server (which is typically built into routers), you have to specify an IP address for the network card. If you are running a private network, you may use IP addresses in the 192.168.0.0 to 192.168.255.255 range. (Other ranges of addresses are reserved for private networks, but this range suffices for most needs.)

Figure 2-5:
The General
tab allows
you to
configure
the con-
nection
to always
attempt to
be available.



Connecting Your LAN to the Internet

If you have a LAN with several PCs, you can connect the entire LAN to the Internet by using DSL or a cable modem. Basically, you can share the high-speed DSL or cable modem connection with all the PCs in the LAN.

Chapter 1 of this minibook explains how to set up a DSL or cable modem. In this section, I briefly explain how to connect a LAN to the Internet so all the PCs can access the Internet.

The most convenient way to connect a LAN to the Internet via DSL or cable modem is to buy a hardware device called *DSL/cable modem NAT router* with a 4- or 8-port Ethernet hub. NAT stands for Network Address Translation, and the NAT router can translate many private IP addresses into a single, externally known IP address. The Ethernet hub part appears to you as a number of RJ-45 Ethernet ports where you can connect the PCs to set up a LAN. In other words, you need only one extra box besides the DSL or cable modem.

Figure 2-6 shows how you might connect your LAN to the Internet through a NAT router with a built-in Ethernet hub. You need a DSL or cable modem hookup for this scenario to work, and you have to sign up with a DSL provider (for DSL service) or with a cable provider for cable Internet service.

When you connect a LAN to the Internet, the NAT router acts as a gateway for your LAN. The NAT router also dynamically provides IP addresses to the PCs in your LAN. Therefore, on each PC, you have to set up the networking options to obtain the IP address dynamically.

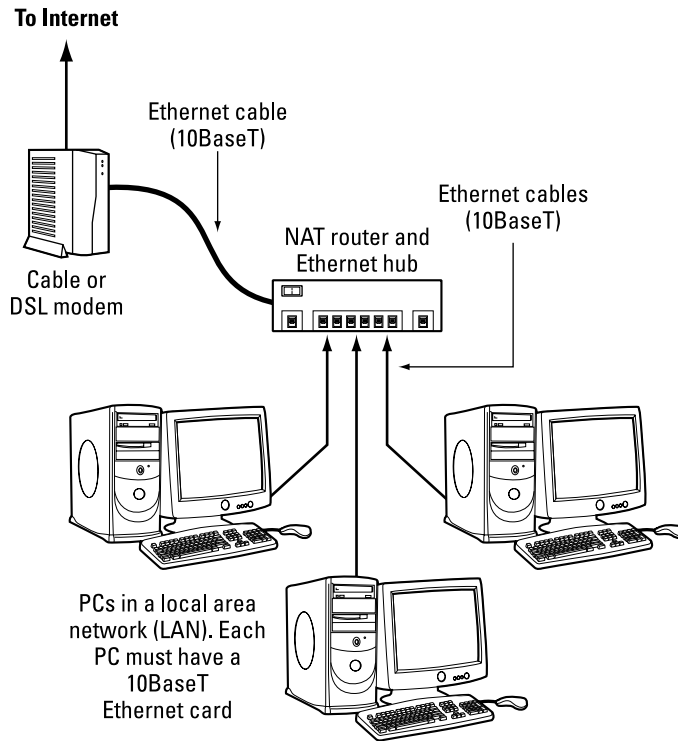

Figure 2-6: Connect your LAN to the Internet through a NAT router with a built-in Ethernet hub.

If you are using DSL and incurring speeds slower than you should (2 Mbps when it should be 5 Mbps, for example), try a different phone cord. Make sure that the phone cord that runs from the modem to the wall jack is no longer than 10 feet and does not go through a filter, surge protector, or splitter (which can attenuate the signal). All other phone devices (fax machines, for example) should go through a filter or surge protector.



Your LAN can mix and match all kinds of computers: Some may be running Linux, and some may be running Microsoft Windows or any other operating system that supports TCP/IP. When configuring the network settings, remember to select the option that enables Linux to automatically obtain IP address settings and DNS information with DHCP.

Chapter 3: Going Wireless

In This Chapter

- ✓ Understanding the wireless Ethernet network
- ✓ Setting up your wireless hardware
- ✓ Finding out how to configure a wireless access point
- ✓ Configuring a wireless network

If you have laptop computers on your LAN — or if you don't want to run a rat's nest of wires to connect a PC to the LAN — you have the option of using a wireless Ethernet network. In a typical scenario, you have a cable modem or DSL connection to the Internet, and you want to connect one or more laptops with wireless network cards to access the Internet through the cable or DSL modem. This chapter shows you how to set up wireless networking for connecting to an Ethernet LAN and accessing the Internet.

Understanding Wireless Ethernet Networks

You've probably heard about Wi-Fi. Wi-Fi stands for *Wireless Fidelity* — a short-range wireless network similar to wired Ethernet networks. A number of standards from an organization known as *IEEE* (the Institute of Electrical and Electronics Engineers) define the technical details of how Wi-Fi networks work. Manufacturers use these standards to build the components that you can buy to set up a *wireless local area network (WLAN)* for short).

The standard governing Wi-Fi networks has evolved swiftly. What started as 802.11a gave birth to 802.11b — and the two combined to make up 802.11g, which was superseded by 802.11n — but the purpose of every one of these standards was the same: to specify how the wireless Ethernet network works at the physical layer. You don't have to fret the details of all those standards to set up a wireless network, but knowing some pertinent details is good so that you can buy the right kind of equipment for your wireless network.

The three wireless Ethernet standards you'll commonly encounter today have the following key characteristics:

- ◆ **802.11b:** Operates in the 2.4 GHz radio band (2.4 GHz to 2.4835 GHz) in up to three nonoverlapping frequency bands or channels. Supports a maximum bit rate of 11 Mbps per channel. One disadvantage of

802.11b is that the 2.4 GHz frequency band is crowded — many devices (such as microwave ovens, cordless phones, medical and scientific equipment, as well as Bluetooth devices), all work within the 2.4 GHz frequency band. Nevertheless, 802.11b is popular in corporate and home networks.

- ◆ **802.11a:** Operates in the 5 GHz radio band (5.725 GHz to 5.850 GHz) in up to eight nonoverlapping channels. Supports a maximum bit rate of 54 Mbps per channel. The 5 GHz band isn't as crowded as the 2.4 GHz band, but the 5 GHz band isn't approved for use in Europe. Products conforming to 802.11a standard are on the market, and some wireless access points are designed to handle both 802.11a and 802.11b connections.
- ◆ **802.11g:** Supports up to 54 Mbps data rate in the 2.4 GHz band (the same band that 802.11b uses). 802.11g achieves the higher bit rate by using a technology called *OFDM* (orthogonal frequency-division multiplexing), which is also used by 802.11a. Equipment that complies with 802.11g is on the market. 802.11g has generated excitement by working in the same band as 802.11b but promising much higher data rates — and by being backward-compatible with 802.11b devices. Vendors currently offer access points that can support both the 802.11b and 802.11g connection standards.

In all cases, the maximum data throughput that a user sees is much less than the channel's total capacity because all users of that radio channel share this capacity. Also, the data-transfer rate decreases as the distance increases between the user's PC and the wireless access point.

To play it safe, though, go with 802.11n with its supported data rates five times the existing throughput and double the range of previous standards.



An 802.11g access point can also communicate with older (and slower) 802.11b devices. You can also consider a MIMO (multiple-input-multiple-output) access point, which supports multiple 802.11 standards and implements techniques for getting higher throughputs and better range.



To find out more about wireless Ethernet, visit www.wi-fi.org, the home page of the Wi-Fi Alliance, which is the nonprofit international association formed in 1999 to certify interoperability of wireless LAN products based on IEEE 802.11 standards.

Understanding infrastructure and ad hoc modes

The 802.11 standard defines two modes of operation for wireless Ethernet networks: ad hoc and infrastructure. *Ad hoc mode* is simply two or more wireless Ethernet cards communicating with each other without an access point.

Infrastructure mode refers to the approach in which all the wireless Ethernet cards communicate with each other and with the wired LAN through an access point. For the discussions in this chapter, I assume that you set your wireless Ethernet card to infrastructure mode. In the configuration files, this mode is referred to as *managed mode*.

Understanding Wired Equivalent Privacy (WEP)

The 802.11 standard includes Wired Equivalent Privacy (WEP) for protecting wireless communications from eavesdropping. WEP relies on a 40-bit or 104-bit secret key that's shared between a mobile station (such as a laptop with a wireless Ethernet card) and an access point (also called a *base station*). The secret key is used to encrypt data packets before they're transmitted, and an integrity check is performed to ensure that packets aren't modified in transit. The 802.11 standard doesn't explain how the shared key is established. In practice, most wireless LANs use a single key that's shared by all of its mobile stations and access points. Such an approach, however, doesn't scale up very well to an environment such as a college campus because the keys are shared with all users — and you know how it is if you share a *secret* with hundreds of people. That's why WEP typically isn't used on large wireless networks, such as the ones at universities. In such wireless networks, you have to use other security approaches, such as SSH (Secure Shell), to log in to remote systems. WEP, however, is good to use on a home wireless network.

WEP has its weaknesses, but it's better than nothing. You can use it in smaller wireless LANs where sharing the same key among all wireless stations isn't an onerous task.



Over a decade ago, the Wi-Fi Alliance published a specification called *Wi-Fi Protected Access* (WPA) that replaced the existing WEP standard and improved security by making some changes. For example, unlike WEP, which uses fixed keys, the WPA standard uses Temporal Key Integrity Protocol (TKIP), which generates new keys for every 10K of data transmitted over the network. This makes WPA more difficult to break. In 2004, the Wi-Fi Alliance introduced a follow-on to WPA called *Wi-Fi Protected Access 2* (WPA2 — the second generation of WPA security). WPA2 is based on the final IEEE 802.11i standard, which uses public key encryption with digital certificates and an authentication, authorization, and accounting RADIUS (Remote Authentication Dial-In User Service) server to provide better security for wireless Ethernet networks. WPA2 uses the Advanced Encryption Standard (AES) for data encryption.

Is the WEP stream cipher good enough?

WEP uses the RC4 encryption algorithm, which is known as a *stream cipher*. Such an algorithm works by taking a short secret key and generating an infinite stream of pseudorandom bits. Before sending the data, the sending station performs an exclusive-OR operation between the pseudorandom bits and the bits representing the data packet, which results in a *1* when two bits are different and *0* if they are the same. The receiver has a copy of the same secret key and generates an identical stream of pseudorandom bits — and performs an identical exclusive-OR operation between this pseudorandom stream and the received bits. Doing so regenerates the original, unencrypted data packet.

This stream-cipher method has a few problems. If a bit is flipped (from a *0* to *1* or vice versa) in the encrypted data stream, the corresponding bit is flipped in the decrypted output, which can help an attacker derive the encryption key. Also, an eavesdropper who intercepts two encoded messages that were encoded with the same stream can generate the exclusive-OR of the original messages. That knowledge is enough to mount attacks that can eventually break the encryption.

To counter these weaknesses, WEP uses some defenses:

- ✔ **Integrity check (IC) field:** To make sure that data packets aren't modified in transit, WEP uses an integrity-check field in each packet.
 - ✔ **Initialization vector (IV):** To avoid encrypting two messages with the same key stream, WEP uses a 24-bit IV that augments the shared secret key to produce a different RC4 key for each packet. The IV itself is also included in the packet.
- Experts say that both these defenses are poorly implemented, making WEP ineffective. IC and IV have two main problems:
- ✔ The integrity-check field is implemented by using a checksum algorithm called *32-bit cyclic redundancy check* (CRC-32); that checksum is then included as part of the data packet. Unfortunately, an attacker can flip arbitrary bits in an encrypted message and correctly adjust the checksum so that the resulting message appears valid.
 - ✔ The 24-bit IV is sent in the clear (unencrypted). There are only 2^{24} possible initialization vectors (no big challenge for a fast machine), and they have to be reused after running through them all. In other words, the IV is repeated after sending 2^{24} , or 16,777,216, packets. The number may sound like a lot, but consider the case of a busy access point that sends 1,500-byte packets at a rate of 11 Mbps. Each packet has 12,000 bits ($8 \times 1,500$). That means the access point sends 916 packets ($11,000,000/12,000$) each second. At that rate, the access point sends 16,777,216 packets in 5 hours ($16,777,216/916 = 18,315$ seconds = 5 hours). That means the IV is reused after 5 hours or less because many messages are smaller than 1,500 bytes. Thus an attacker has ample opportunities to collect two messages encrypted with the same key stream — and perform *statistical attacks* (which amount to trying the possible *combinations* really fast) to decrypt the message.

Setting Up Wireless Hardware

To set up the wireless connection, you need a wireless access point and a wireless network card in each PC. You can also set up an ad hoc wireless network among two or more PCs with wireless network cards, but that is a standalone wireless LAN among those PCs only. In this section, I focus on the scenario in which you want to set up a wireless connection to an established LAN that has a wired Internet connection through a cable modem or DSL.

In addition to the wireless access point, you also need a cable modem or DSL connection to the Internet, along with a NAT router and hub, as described in Chapters 1 and 2 of this minibook. Figure 3-1 shows a typical setup for wireless Internet access through an existing cable modem or DSL connection.

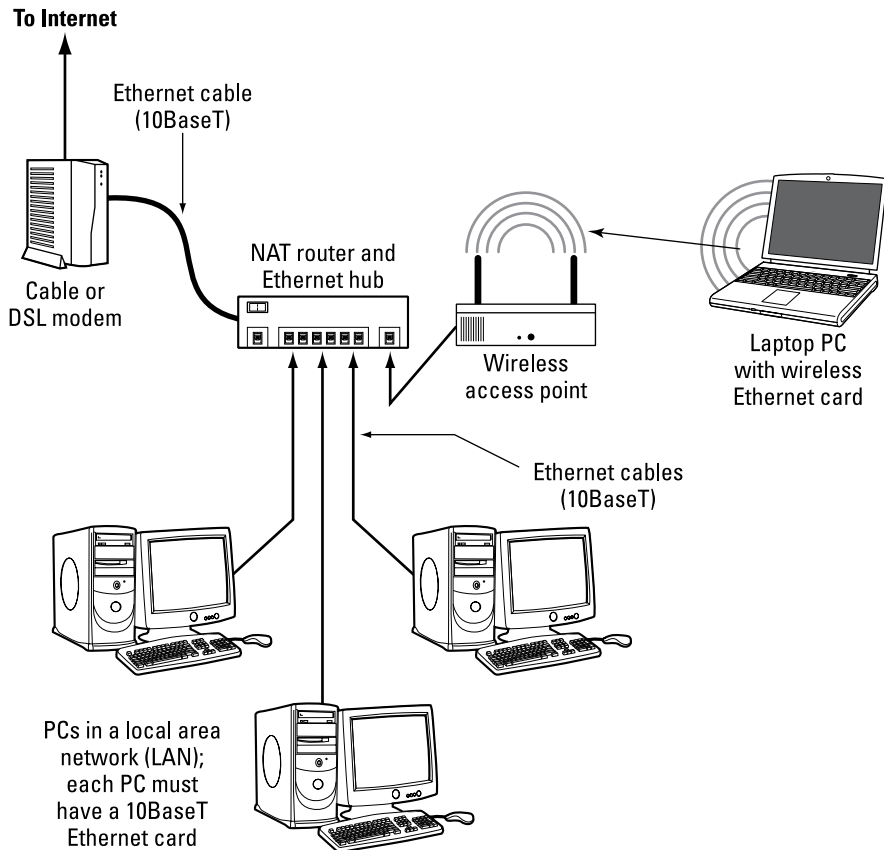

Figure 3-1: Typical connection of a mixed wired and wireless Ethernet LAN to the Internet.

As Figure 3-1 shows, the LAN has both wired and wireless PCs. In this example, either a cable or DSL modem connects the LAN to the Internet through a NAT router and hub. Laptops with wireless network cards connect to the LAN through a wireless access point attached to one of the RJ-45 ports on the hub. To connect desktop PCs to this wireless network, you can use a USB wireless network card (which connects to a USB port).



If you haven't yet purchased a NAT router and hub for your cable or DSL connection, consider buying a router and hub that has a built-in wireless access point.

Configuring the Wireless Access Point

Configuring the wireless access point (commonly referenced as either an AP or WAP) involves the following tasks:

- ◆ **Setting a name for the wireless network.** (The technical term for this name is the ESSID.)
- ◆ **Setting the frequency or channel on which the wireless access point communicates with the wireless network cards.** The access point and the cards must use the same channel.
- ◆ **Deciding whether to use encryption.**
- ◆ **If encryption is to be used, setting the number of bits in the encryption key and the value of the encryption key.** For the encryption key, 24 bits are internal to the access point; you specify only the remaining bits. Thus, for 64-bit encryption, you have to specify a 40-bit key, which comes to 10 hexadecimal digits. (A *hexadecimal digit* is an integer from 0–9 or a letter from A–F.) For a 128-bit encryption key, you specify 104 bits, or 26 hexadecimal digits.
- ◆ **Setting the access method that wireless network cards must use when connecting to the access point.** You can opt for either open access or shared key. The open-access method is typical (even when using encryption).
- ◆ **Setting the wireless access point to operate in infrastructure (managed) mode.** You use this mode to connect wireless network cards to an existing Ethernet LAN.



The exact method of configuring a wireless access point depends on the device's make and model; the vendor provides instructions to configure the wireless access point. Typically you work through a graphical client application on a Windows PC to do the configuration. If you enable encryption, make note of the encryption key; you have to specify that same key for each wireless network card on your laptops or desktops.

Configuring Wireless Networking

On your Linux laptop, the PCMCIA or PC Card manager recognizes the wireless network card and loads the appropriate driver for the card. Linux treats the wireless network card like another Ethernet device and assigns it a device name such as `eth0` or `eth1`. If you already have an Ethernet card in the laptop, that card gets the `eth0` device name and the wireless PC Card becomes the `eth1` device.

You do have to configure certain parameters to enable the wireless network card to communicate with the wireless access point. For example, you have to specify the wireless network name assigned to the access point, and the encryption settings must match those on the access point. You can usually configure everything using a graphical network-configuration tool that's available for your Linux distribution — just select the Wireless Network option and fill in the requested information, such as that shown in Figure 3-2.

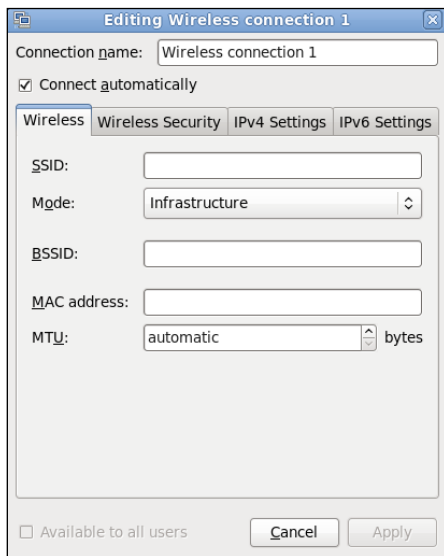

Figure 3-2:
Configuring
a new
wireless
connection.



The Network Configuration tool saves your wireless network settings in a text file. The name of the text file depends on the wireless network device name. If the wireless network device name is `eth0`, the configuration is stored in the text file `/etc/sysconfig/network-scripts/ifcfg-eth0`. If the wireless device name is `eth1`, the file is `/etc/sysconfig/network-scripts/ifcfg-eth1`. This configuration file contains various settings for the wireless network card. Table 3-1 explains the meaning of the settings. Here is a slightly edited version of the `/etc/sysconfig/network-scripts/ifcfg-eth1` file from my laptop PC:

```

IPV6INIT=no
USERCTL=no
PEERDNS=yes
TYPE=Wireless
DEVICE=eth1
HWADDR=00:02:2d:8c:f9:c4
BOOTPROTO=dhcp
ONBOOT=no
DHCP_HOSTNAME=
NAME=
ESSID='HOME'
CHANNEL=6
MODE=Managed
RATE=auto

```

Table 3-1 **Settings in Configuration File for a Wireless Ethernet Network Interface**

| <i>This Parameter</i> | <i>Means the Following</i> |
|-----------------------|---|
| BOOTPROTO | The name of the protocol to use to get the IP address for the interface. The protocol used is either <code>dhcp</code> or <code>bootp</code> for an Ethernet interface. |
| CHANNEL | Channel number (between 1 and 14 in United States and Canada). Must be the same as that set for the wireless access point. In managed mode, you don't need to specify the channel. |
| DEVICE | The device name for the wireless Ethernet network interface (<code>eth0</code> for the first interface, <code>eth1</code> for the second, and so on). |
| ESSID | Extended Service Set (ESS) Identifier (ID), also known as the wireless network name. It is case-sensitive and must be the same as the name specified for the wireless access point. Provide the name within single quotes (for example, 'HOME'). |
| HWADDR | The hardware address (also called the MAC address) of the wireless network card (six pairs of colon-separated hexadecimal numbers; for example, <code>00:02:2d:8c:f9:c4</code>). The wireless card's device driver automatically detects this address. |
| IPV6INIT | When set to <code>yes</code> , this parameter initializes IPv6 configuration for the wireless interface. Set it to <code>no</code> if you're not using IPv6. |
| MODE | The mode of operation of the wireless network card. Set to <code>Managed</code> for a typical network that connects through a wireless access point. |

| <i>This Parameter</i> | <i>Means the Following</i> |
|-----------------------|--|
| NAME | A nickname for your wireless network. If you don't specify it, the host name is used as the nickname. |
| ONBOOT | Set to <code>yes</code> to activate the wireless interface at boot time; otherwise set to <code>no</code> . |
| PEERDNS | Set to <code>yes</code> to enable the interface to modify your system's <code>/etc/resolv.conf</code> file to use the DNS servers obtained from the DHCP server (the same server that provides the IP address for the interface). If you set this parameter to <code>no</code> , the <code>/etc/resolv.conf</code> file is left unchanged. |
| RATE | Bit rate for the wireless connection (set to one of the following options: <code>1M</code> , <code>2M</code> , <code>5.5M</code> , <code>11M</code> , or <code>auto</code>). The <i>M</i> means Mbps, or a million bits per second. Set to <code>auto</code> to use the maximum possible transmission rate. |
| TYPE | Set to <code>Wireless</code> for wireless network interface. |
| USERCTL | When set to <code>yes</code> , a user who isn't logged in as <code>root</code> can control the device. Set it to <code>no</code> so that only <code>root</code> can control the device. |

In some Linux distributions, the encryption key is stored separately. For a wireless Ethernet card whose device name is `eth1`, the encryption key is stored in the `/etc/sysconfig/network-scripts/keys-eth1` file. Here is what this file contains for my example:

```
KEY=1fdf3fdefe
```



The key has 10 hexadecimal digits for a 40-bit key (for example, `1fdf-3fde-fe`) or 26 hexadecimal digits for a 104-bit key. The keys are 64-bit and 128-bit, respectively, but the encryption algorithm automatically generates 24 bits of the key, so you need to specify only the remaining bits. The longer the key, the more secure the encryption.



If you ever manually edit the parameters in the wireless Ethernet configuration file, type the following command to reactivate the wireless network interface after editing the configuration file:

```
/etc/init.d/network restart
```



In SUSE Linux, use YaST to configure the wireless network. SUSE stores the wireless configuration parameters in a file whose name begins with `ifcfg-wlan`, followed by a number such as `0` or `1`, depending on the sequence number of the wireless network interface.

The configuration file is stored in the `/etc/sysconfig/network` directory. Here's a typical list of wireless configuration parameters from a configuration file in SUSE Linux:

```
WIRELESS_MODE='Managed'  
WIRELESS_ESSID='HOME'  
WIRELESS_NICK=''  
WIRELESS_RATE='auto'  
WIRELESS_AUTH_MODE='open'  
WIRELESS_KEY_0='0123-4567-89'
```



To check the status of the wireless network interface, type the following command:

```
iwconfig
```

Here's a typical output from a laptop with a wireless Ethernet PC card. (The output should be similar in other Linux distributions.)

```
lo no wireless extensions.  
eth0 no wireless extensions.  
sit0 no wireless extensions.  
eth1 IEEE 802.11b ESSID:"HOME" Nickname:"localhost.localdomain"  
Mode:Managed Frequency:2.437 GHz Access Point: 00:30:AB:06:E2:5D  
Bit Rate=11 Mb/s Sensitivity:1/3  
Retry limit:4 RTS thr:off Fragment thr:off  
Encryption key:1FDF-3FDE-FE Security mode:open  
Power Management:off  
Link Quality=51/92 Signal level=-40 dBm Noise level=-91 dBm  
Rx invalid nwid:0 Rx invalid crypt:0 Rx invalid frag:27  
Tx excessive retries:0 Invalid misc:0 Missed beacon:0
```

Here the `eth1` interface refers to the wireless network card. I edited the encryption key and some other parameters to hide those details, but the sample output shows you what you'd typically see when the wireless link is working.

Chapter 4: Managing the Network

In This Chapter

- ✓ Finding out about the TCP/IP configuration files
- ✓ Checking TCP/IP networks
- ✓ Configuring networks at boot time

Like almost everything else in Linux, TCP/IP setup is a matter of preparing numerous configuration files (text files you can edit with any text editor). Most of these configuration files are in the `/etc` directory. The Linux installer tries to be helpful by hiding the details of the TCP/IP configuration files. Nevertheless, if you know the names of the files and their purposes, editing the files manually (if necessary) is easier.

Discovering the TCP/IP Configuration Files

You can configure TCP/IP networking when you install Linux. However, if you want to effectively manage the network, you need to become familiar with the TCP/IP configuration files so that you can edit the files, if necessary. (For example, if you want to check whether the name servers are specified correctly, you have to know about the `/etc/resolv.conf` file, which stores the IP addresses of name servers.)



Table 4-1 summarizes the basic TCP/IP configuration files. I describe these configuration files in the next few sections.



A pound sign (#) in a text file indicates a comment.

/etc/hosts

The `/etc/hosts` text file contains a list of IP addresses and host names for your local network. In the absence of a name server, any network program on your system consults this file to determine the IP address that corresponds to a host name. Think of `/etc/hosts` as the local phone directory where you can look up the IP address (instead of a phone number) for a local host.

Table 4-1 Basic TCP/IP Network Configuration Files

| <i>This File</i> | <i>Contains the Following</i> |
|---------------------------------|--|
| <code>/etc/hosts</code> | IP addresses and host names for your local network as well as any other systems that you access often. |
| <code>/etc/networks</code> | Names and IP addresses of networks. |
| <code>/etc/host.conf</code> | Instructions on how to translate host names into IP addresses. |
| <code>/etc/resolv.conf</code> | IP addresses of name servers. |
| <code>/etc/hosts.allow</code> | Instructions on which systems can access Internet services on your system. |
| <code>/etc/hosts.deny</code> | Instructions on which systems must be denied access to Internet services on your system. |
| <code>/etc/nsswitch.conf</code> | Instructions on how to translate host names into IP addresses. |

Here is the `/etc/hosts` file from a system, showing the IP addresses and names of other hosts on a typical LAN:

```
127.0.0.1 localhost localhost.localdomain
# Other hosts on the LAN
192.168.0.100 lnbp933
192.168.0.50 lnbp600
192.168.0.200 lnbp200
192.168.0.233 lnbp233
192.168.0.40 lnbp400
```

As the example shows, each line in the file starts with an IP address followed by the host name for that IP address. (You can have more than one host name for any given IP address.) In some distributions, such as openSUSE, the `/etc/hosts` file has the following: IP-Address, Fully-Qualified-Hostname, Short-Hostname. In all cases, anything after the host name (such as the Short-Hostname) is taken as an alias.

/etc/networks

`/etc/networks` is another text file that contains the names and IP addresses of networks. These network names are commonly used in the routing command (`/sbin/route`) to specify a network by name instead of by its IP address.

Don't be alarmed if your Linux PC doesn't have the `/etc/networks` file. Your TCP/IP network works fine without this file. In fact, the Linux installer doesn't create a `/etc/networks` file.

/etc/host.conf

Linux uses a special *library* (that is, a collection of computer code) called the *resolver* to obtain the IP address that corresponds to a host name. The `/etc/host.conf` file specifies how names are *resolved* (that is, how the name gets converted to a numeric IP address). A typical `/etc/host.conf` file might contain the following lines:

```
order hosts, bind
multi on
```

The entries in the `/etc/host.conf` file tell the resolver what services to use (and in which order) to resolve names.

The `order` option indicates the order of services (in recent distributions, the `nsswitch.conf` file, discussed in a later section, performs this function). The sample entry tells the resolver to first consult the `/etc/hosts` file and then check the name server to resolve a name.



Use the `multi` option to indicate whether a host in the `/etc/hosts` file can have multiple IP addresses. Hosts that have more than one IP address are called *multihomed* because the presence of multiple IP addresses implies that the host has several network interfaces. (In effect, the host *lives* in several networks simultaneously.)

/etc/resolv.conf

The `/etc/resolv.conf` file is another text file used by the resolver — the library that determines the IP address for a host name. Here is a sample `/etc/resolv.conf` file:

```
nameserver 192.168.0.1 # dhcp: eth0
search nrockv01.md.comcast.net
```

The `nameserver` line provides the IP addresses of name servers for your domain. If you have multiple name servers, list them on separate lines. They're queried in the order in which they appear in the file.

The `search` line tells the resolver how to search for a host name. For example, when trying to locate a host name `myhost`, the `search` directive in the example causes the resolver to try `myhost.nrockv01.md.comcast.net` first, then `myhost.md.comcast.net`, and finally `myhost.comcast.net`.



If you don't have a name server for your network, you can safely ignore this file. TCP/IP still works, even though you may not be able to refer to hosts by name (other than those listed in the `/etc/hosts` file).

/etc/hosts.allow

The `/etc/hosts.allow` file specifies which hosts are allowed to use the Internet services (such as TELNET and FTP) running on your system. This file is consulted before certain Internet services start. The services start only if the entries in the `hosts.allow` file imply that the requesting host is allowed to use the services.

The entries in `/etc/hosts.allow` are in the form of a *server:IP address* format, where *server* refers to the name of the program providing a specific Internet service and *IP address* identifies the host allowed to use that service. For example, if you want all hosts in your local network (which has the network address 192.168.0.0) to access the TELNET service (provided by the `in.telnetd` program), add the following line in the `/etc/hosts.allow` file (the last octet is left off to signify all possibilities within that range):

```
in.telnetd:192.168.0.
```

If you want to let all local hosts have access to all Internet services, you can use the `ALL` keyword and rewrite the line as follows:

```
ALL:192.168.0.
```

Finally, to open all Internet services to all hosts, you can replace the IP address with `ALL`, as follows:

```
ALL:ALL
```

You can also use host names in place of IP addresses.



To find out the detailed syntax of the entries in the `/etc/hosts.allow` file, type **man hosts.allow** at the shell prompt in a terminal window.

/etc/hosts.deny

The `/etc/hosts.deny` file is just the opposite of `/etc/hosts.allow`. Whereas `hosts.allow` specifies which hosts may access Internet services (such as TELNET and TFTP) on your system, the `hosts.deny` file identifies the hosts that must be denied services. The `/etc/hosts.deny` file is consulted if no rules are in the `/etc/hosts.allow` file that apply to the requesting host. Service is denied if the `hosts.deny` file has a rule that applies to the host.

The entries in `/etc/hosts.deny` file have the same format as those in the `/etc/hosts.allow` file; they're in the form of a *server:IP address* format, where *server* refers to the name of the program providing a specific Internet service and *IP address* identifies the host that must not be allowed to use that service.

If you already set up entries in the `/etc/hosts.allow` file to allow access to specific hosts, you can place the following line in `/etc/hosts.deny` to deny all other hosts access to any service on your system:

ALL:ALL



To find out the detailed syntax of the entries in the `/etc/hosts.deny` file, type **man hosts.deny** at the shell prompt in a terminal window.

/etc/nsswitch.conf

The `/etc/nsswitch.conf` file, known as the *name service switch* (NSS) file, specifies how services such as the resolver library, NIS, NIS+, and local configuration files (such as `/etc/hosts` and `/etc/shadow`) interact.

NIS and NIS+ are *network information systems* — another type of name-lookup service. Newer versions of the Linux kernel use the `/etc/nsswitch.conf` file to determine what takes precedence: a local configuration file, a service such as DNS (Domain Name System), or NIS.

As an example, the following `hosts` entry in the `/etc/nsswitch.conf` file says that the resolver library first tries the `/etc/hosts` file, then tries NIS+, and finally tries DNS:

```
hosts: files nisplus dns
```



You can find out more about the `/etc/nsswitch.conf` file by typing **man nsswitch.conf** in a terminal window.

Checking Out TCP/IP Networks

After you configure Ethernet and TCP/IP (whether during Linux installation or by running a network configuration tool or command later), you can use various networking applications without much problem. On the off chance that you do run into trouble, Linux includes several tools to help you monitor and diagnose problems.

Checking the network interfaces

Use the `/sbin/ifconfig` command to view the currently configured network interfaces. The `ifconfig` command is used to configure a network interface (that is, to associate an IP address with a network device). If you run `ifconfig` without any command-line arguments, the command displays information about current network interfaces. The following is a typical output when you type `/sbin/ifconfig`:

```
eth0 Link encap:Ethernet HWaddr 00:08:74:E5:C1:60
inet addr:192.168.0.7 Bcast:192.168.0.255 Mask:255.255.255.0
inet6 addr: fe80::208:74ff:fee5:c160/64 Scope:Link
UP BROADCAST RUNNING MULTICAST MTU:1500 Metric:1
```

```
RX packets:612851 errors:0 dropped:0 overruns:0 frame:0
TX packets:574187 errors:0 dropped:0 overruns:0 carrier:0
collisions:0 txqueuelen:1000
RX bytes:99834031 (95.2 MiB) TX bytes:76034821 (72.5 MiB)
Interrupt:10 Base address:0x3000
eth1 Link encap:Ethernet HWaddr 00:02:2D:8C:F8:C5
inet addr:192.168.0.9 Bcast:192.168.0.255 Mask:255.255.255.0
inet6 addr: fe80::202:2dff:fe8c:f8c5/64 Scope:Link
UP BROADCAST RUNNING MULTICAST MTU:1500 Metric:1
RX packets:3833 errors:0 dropped:0 overruns:0 frame:0
TX packets:1242 errors:0 dropped:0 overruns:0 carrier:0
collisions:0 txqueuelen:1000
RX bytes:560194 (547.0 KiB) TX bytes:250287 (244.4 KiB)
Interrupt:3 Base address:0x100
lo Link encap:Local Loopback
inet addr:127.0.0.1 Mask:255.0.0.0
inet6 addr: ::1/128 Scope:Host
UP LOOPBACK RUNNING MTU:16436 Metric:1
RX packets:2456 errors:0 dropped:0 overruns:0 frame:0
TX packets:2456 errors:0 dropped:0 overruns:0 carrier:0
collisions:0 txqueuelen:0
RX bytes:2891581 (2.7 MiB) TX bytes:2891581 (2.7 MiB)
```

This output shows that three network interfaces — the loopback interface (`lo`) and two Ethernet cards (`eth0` and `eth1`) — are currently active on this system. For each interface, you can see the IP address, as well as statistics on packets delivered and sent. If the Linux system has a dial-up PPP link up and running, you also see an item for the `ppp0` interface in the output.

Checking the IP routing table

The other network configuration command, `/sbin/route`, also provides status information when you run it without a command-line argument. If you're having trouble checking a connection to another host (that you specify with an IP address), check the IP routing table to see whether a default gateway is specified. Then check the gateway's routing table to ensure that paths to an outside network appear in that routing table.

A typical output from the `/sbin/route` command looks like the following:

```
Kernel IP routing table
Destination Gateway Genmask Flags Metric Ref Use Iface
192.168.0.0 * 255.255.255.0 U 0 0 0 eth0
192.168.0.0 * 255.255.255.0 U 0 0 0 eth1
169.254.0.0 * 255.255.0.0 U 0 0 0 eth1
default 192.168.0.1 0.0.0.0 UG 0 0 0 eth0
```

As this routing table shows, the local network uses the `eth0` and `eth1` Ethernet interfaces, and the default gateway is the `eth0` Ethernet interface. The default gateway is a routing device that handles packets addressed to any network other than the one in which the Linux system resides. In this example, packets addressed to any network address other than those beginning with `192.168.0` are sent to the gateway — `192.168.0.1`. The gateway forwards those packets to other networks (assuming, of course, that the gateway is connected to another network, preferably the Internet).

Checking connectivity to a host

To check for a network connection to a specific host, use the `ping` command. `ping` is a widely used TCP/IP tool that uses a series of Internet Control Message Protocol (ICMP, pronounced *EYE-comp*) messages. ICMP provides for an echo message to which every host responds. Using the ICMP messages and replies, `ping` can determine whether the other system is alive and can compute the round-trip delay in communicating with that system.

The following example shows how I run `ping` to see whether a system on my network is alive:

```
ping 192.168.0.1
```

Here is what this command displays on my home network:

```
PING 192.168.0.1 (192.168.0.1) 56(84) bytes of data.
64 bytes from 192.168.0.1: icmp_seq=1 ttl=63 time=0.256 ms
64 bytes from 192.168.0.1: icmp_seq=2 ttl=63 time=0.267 ms
64 bytes from 192.168.0.1: icmp_seq=3 ttl=63 time=0.272 ms
64 bytes from 192.168.0.1: icmp_seq=4 ttl=63 time=0.267 ms
64 bytes from 192.168.0.1: icmp_seq=5 ttl=63 time=0.275 ms
--- 192.168.0.1 ping statistics ---
5 packets transmitted, 5 received, 0% packet loss, time 3999ms
rtt min/avg/max/mdev = 0.256/0.267/0.275/0.016 ms
```

In Linux, `ping` continues to run until you press `Ctrl+C` to stop it; then it displays summary statistics showing the typical time it takes to send a packet between the two systems. On some systems, `ping` simply reports that a remote host is alive. However, you can still get the timing information by using appropriate command-line arguments.



The `ping` command relies on ICMP messages that many firewalls are configured to block. Therefore `ping` may not always work and is no longer a reliable way to test network connectivity. If `ping` fails for a specific host, don't assume that the host is down or not connected to the network. You can typically use `ping` to successfully check connectivity within your local area network.

Checking network status

To check the status of the network, use the `netstat` command. This command displays the status of network connections of various types (such as TCP and UDP connections). You can view the status of the interfaces quickly by typing `netstat -i`, which results in an output similar to the following:

```
Kernel Interface table
Iface MTU Met RX-OK RX-ERR RX-DRP RX-OVR TX-OK TX-ERR TX-DRP TX-OVR Flg
eth0 1500 0 613175 0 0 1 574695 0 0 0 BMRU
eth1 1500 0 4298 0 0 0 1375 1 0 0 BMRU
lo 16436 0 3255 0 0 0 3255 0 0 0 LRU
```

In this case, the output shows the current status of the loopback and Ethernet interfaces.



Table 4-2 describes the meanings of the columns.

| Column | Meaning |
|-------------------|--|
| Iface | Name of the interface |
| MTU | Maximum Transmission Unit — the maximum number of bytes that a packet can contain |
| Met | Metric value for the interface — a number indicating distance (in terms of number of hops) that routing software uses when deciding which interface to send packets through |
| RX-OK, TX-OK | Number of error-free packets received (RX) or transmitted (TX) |
| RX-ERR, TX-ERR | Number of packets with errors |
| RX-DRP, TX-DRP | Number of dropped packets |
| RX-OVR, TX-OVR | Number of packets lost due to overflow |
| Flg | A = receive multicast; B = broadcast allowed; D = debugging turned on; L = loopback interface (notice the flag on l0), M = all packets received, N = trailers avoided; O = no ARP on this interface; P = point-to-point interface; R = interface is running; and U = interface is up |

Another useful form of `netstat` option is `-t`, which shows all active TCP connections. Following is a typical result of typing `netstat -t` on one Linux PC:

```
Active Internet connections (w/o servers)
Proto Recv-Q Send-Q Local Address Foreign Address State
tcp 0 0 localhost:2654 localhost:1024 ESTABLISHED
tcp 0 0 localhost:1024 localhost:2654 ESTABLISHED
tcp 0 0 LNBNECXAN.nrockv01.:ssh 192.168.0.6:1577 ESTABLISHED
```

In this case, the output columns show the protocol (Proto), the number of bytes in the receive and transmit queues (Recv-Q, Send-Q), the local TCP port in `hostname:service format` (Local Address), the remote port (Foreign Address), and the state of the connection.

Type `netstat -ta` to see all TCP connections — both active and the ones your Linux system is listening to (with no connection established yet). For example, here's a typical output from the `netstat -ta` command:

```
Active Internet connections (servers and established)
Proto Recv-Q Send-Q Local Address Foreign Address State
tcp 0 0 *:32769 *: * LISTEN
```

```

tcp 0 0 *:mysql *:* LISTEN
tcp 0 0 *:sunrpc *:* LISTEN
tcp 0 0 *:ftp *:* LISTEN
tcp 0 0 localhost.localdomain:ipp *:* LISTEN
tcp 0 0 *:telnet *:* LISTEN
tcp 0 0 localhost.localdomain:5335 *:* LISTEN
tcp 0 0 localhost.localdomain:smtp *:* LISTEN
tcp 0 0 192.168.0.9:45876 www.redhat.com:http ESTABLISHED
tcp 0 0 192.168.0.9:45877 www.redhat.com:http ESTABLISHED
tcp 0 0 192.168.0.9:45875 www.redhat.com:http ESTABLISHED
tcp 0 0 *:ssh *:* LISTEN
tcp 0 0 ::ffff:192.168.0.7:ssh ::ffff:192.168.0.3:4932 ESTABLISHED
    
```

Sniffing network packets

Sniffing network packets — sounds like something illegal, doesn't it? Nothing like that. *Sniffing* simply refers to viewing the TCP/IP network data packets. The concept is to capture all the network packets so that you can examine them later.



If you feel like sniffing TCP/IP packets, you can use `tcpdump`, a command-line utility that comes with Linux. As its name implies, it *dumps* (prints) the headers of TCP/IP network packets.

To use `tcpdump`, log in as `root` and type the `tcpdump` command in a terminal window. Typically, you want to save the output in a file and examine that file later. Otherwise `tcpdump` starts spewing results that just flash by on the window. For example, to capture 1,000 packets in a file named `tdout` and attempt to convert the IP addresses to names, type the following command:

```
tcpdump -a -c 1000 > tdout
```

After capturing 1,000 packets, `tcpdump` quits. Then you can examine the output file, `tdout`. It's a text file, so you can simply open it in a text editor or type **more `tdout`** to view the captured packets.

Just to whet your curiosity, here are some lines from a typical output from `tcpdump`:

```

20:05:57.723621 arp who-has 192.168.0.1 tell
    LNBNECXAN.nrockv01.md.comcast.net
20:05:57.723843 arp reply 192.168.0.1 is-at 0:9:5b:44:78:fc
20:06:01.733633 LNBNECXAN.nrockv01.md.comcast.net.1038 > 192.168.0.6.auth:
    S 536321100:536321100(0) win 5840 <mss 1460,sackOK,timestamp 7030060
    0,nop,wscale 0> (DF)
20:06:02.737022 LNBNECXAN.nrockv01.md.comcast.net.ftp > 192.168.0.6.1596:
    P 1:72 (71) ack 1 win 5840 (DF)
20:06:02.935335 192.168.0.6.1596 > LNBNECXAN.nrockv01.md.comcast.net.ftp:
    . ack 72 win 65464 (DF)
20:06:05.462481 192.168.0.6.1596 > LNBNECXAN.nrockv01.md.comcast.net.ftp:
    P 1:12 (11) ack 72 win 65464 (DF)
20:06:05.462595 LNBNECXAN.nrockv01.md.comcast.net.ftp > 192.168.0.6.1596:
    . ack 12 win 5840 (DF)
20:06:05.465344 LNBNECXAN.nrockv01.md.comcast.net.ftp > 192.168.0.6.1596:
    P 72:105(33) ack 12 win 5840 (DF)
. . . lines deleted . . .
    
```

The output offers some clues to what's going on, with each line showing information about one network packet. Every line starts with a timestamp followed by details of the packet (information such as where it originates and where it is going). I don't try to explain the details here, but you can type **man tcpdump** to find out more about some of the details (and more importantly, see what other ways you can use `tcpdump`).



If `tcpdump` isn't installed in Debian, type **apt-get install tcpdump** to install it.

You can use another packet sniffer called Wireshark in Linux. To find out more about Wireshark, visit www.wireshark.org/.

Using GUI tools

You can check the status of your network through the graphical interfaces a number of ways. One of those is to use the System Monitor, as shown in Figure 4-1. In addition to seeing the network load, you can click the Processes tab to see the status of various processes.

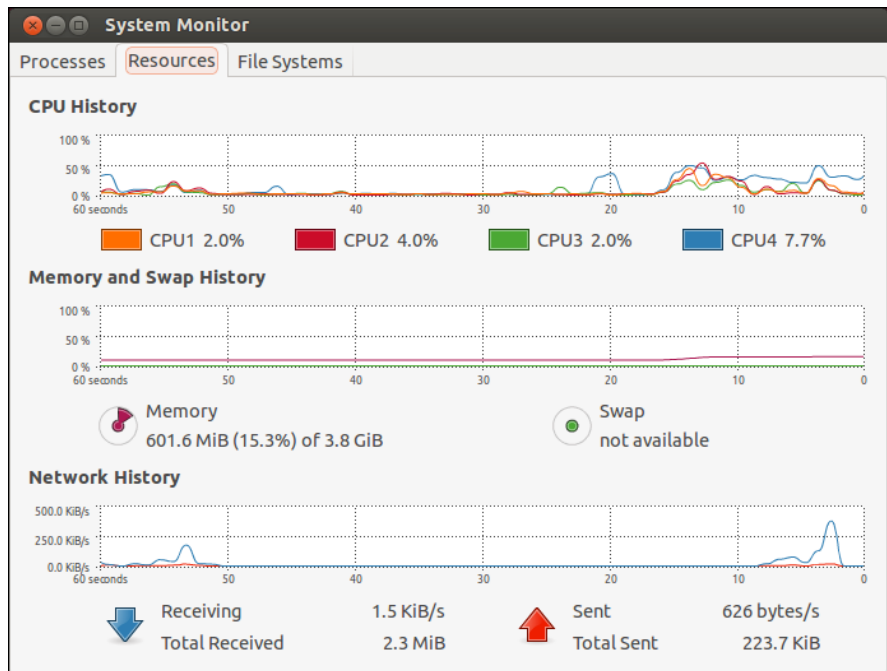

Figure 4-1:
The System Monitor.

Configuring Networks at Boot Time

It makes sense to start your network automatically every time you boot the system. For that to happen, various startup scripts must contain appropriate commands. You don't have to do anything special other than configure your network (either during installation or by using the network configuration tool at a later time). If the network balks at startup, however, you can troubleshoot by checking the files I mention in this section.



In Debian, Ubuntu, and Xandros, the `/etc/network/interfaces` file describes the network interfaces available in your system, and the `/sbin/ifup` command activates the interfaces when you boot the system. Here is the content of a typical `/etc/network/interfaces` file from a Debian system:

```
# This file describes the network interfaces available on your system
# and how to activate them. For more information, see interfaces(5).
# The loopback network interface
auto lo
iface lo inet loopback
# The primary network interface
auto eth0
iface eth0 inet dhcp
```

The `auto eth0` line indicates that you can bring up the Ethernet interface at initialization by using the command `ifup -a` invoked by a system startup script. The line `iface eth0 inet dhcp` identifies Ethernet as a TCP/IP network interface that is configured by Dynamic Host Configuration Protocol (DHCP).



In Fedora, the network-activation script uses a set of text files in the `/etc/sysconfig` directory to activate the network interfaces. For example, the script checks the variables defined in the `/etc/sysconfig/network` file to decide whether to activate the network. In `/etc/sysconfig/network`, you see a line with the `NETWORKING` variable as follows:

```
NETWORKING=yes
```

The network activates only if the `NETWORKING` variable is set to `yes`. A number of scripts in the `/etc/sysconfig/network-scripts` directory activate specific network interfaces. For example, the configuration file for activating the Ethernet interface `eth0` is the file `/etc/sysconfig/network-scripts/ifcfg-eth0`. Here's what a typical `/etc/sysconfig/network-scripts/ifcfg-eth0` file contains:

```
DEVICE=eth0
BOOTPROTO=dhcp
HWADDR=00:08:74:E5:C1:06
ONBOOT=yes
TYPE=Ethernet
```

The `DEVICE` line provides the network device name. The `BOOTPROTO` variable is set to `dhcp`, indicating that the IP address is obtained dynamically by using DHCP. The `ONBOOT` variable states whether this network interface activates when Linux boots. If your PC has an Ethernet card and you want to activate the `eth0` interface at boot time, `ONBOOT` must be set to `yes`. The configuration file `ifcfg-eth0` in the `/etc/sysconfig/network-scripts` directory works only if your PC has an Ethernet card and the Linux kernel has detected and loaded the specific driver for that card.



In SUSE, the network information is kept in the `/etc/sysconfig/network` directory in files with names beginning with `ifcfg`. For Ethernet interfaces, the configuration filename begins with `ifcfg-eth-id-` followed by the unique hardware address of the Ethernet card. Here are the key lines in a typical Ethernet configuration file:

```
BOOTPROTO='dhcp'  
STARTMODE='auto'
```

The `BOOTPROTO='dhcp'` line indicates that the interface is set up using DHCP, and `STARTMODE='auto'` means that the interface is initialized when the system boots.

Within KDE, you can start the Control Center by typing **Session Management** in the Search box and configuring the default operations for the system, as shown in Figure 4-2.

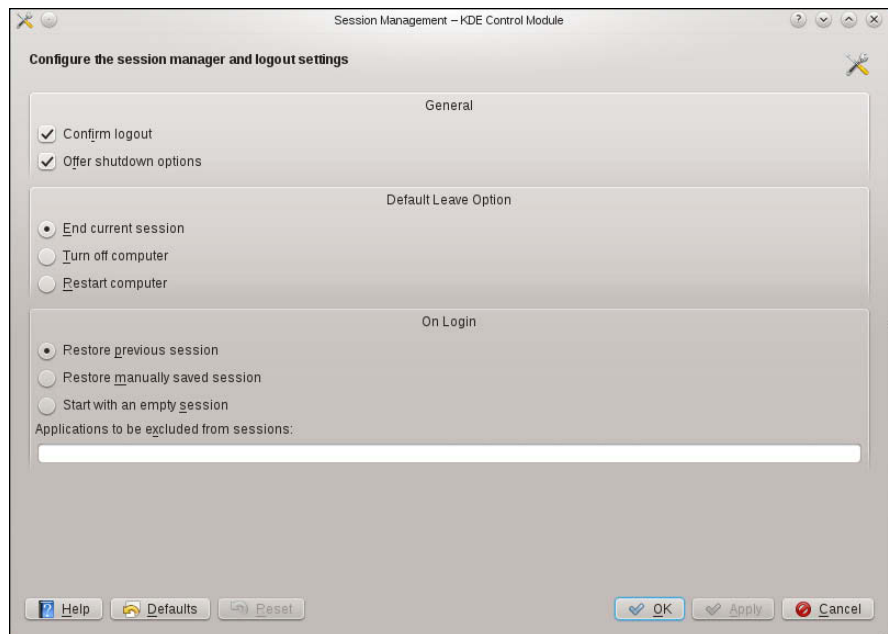
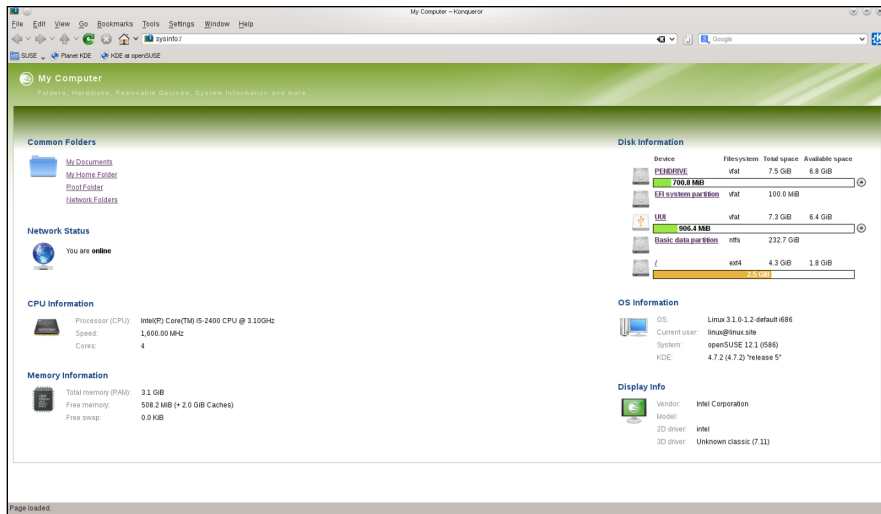

Figure 4-2:
The Session Management interface.

Another useful interface that can give you a quick look at whether the network is up and running is System Information, shown in Figure 4-3. Although this interface offers no way to change configuration settings, it's nice to have a tool that can quickly show you the status of the system, including network status.

Figure 4-3:
System
Information
can show
the network
status.



Book IV

The Internet

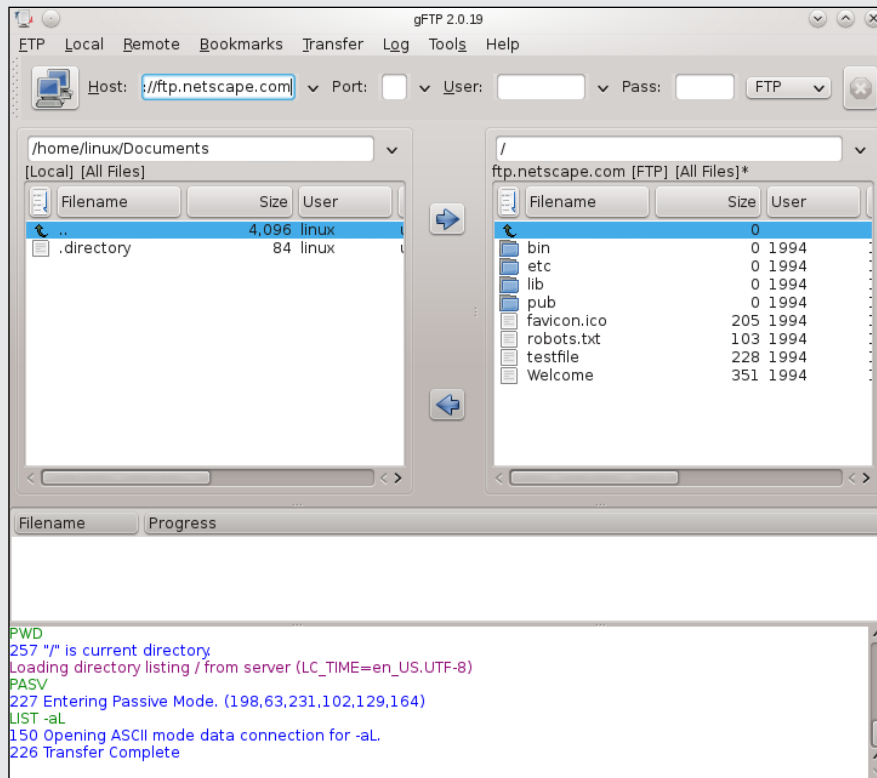

Visit www.dummies.com/extras/linuxaio for great Dummies content online.

Contents at a Glance

| | |
|--|------------|
| Chapter 1: Browsing the Web | 205 |
| Discovering the Web..... | 205 |
| Web Browsing in Linux..... | 209 |
| Chapter 2: Reading Newsgroups and RSS Feeds | 217 |
| Understanding Newsgroups..... | 218 |
| Reading Newsgroups from Your ISP..... | 222 |
| Reading and Searching Newsgroups at Websites..... | 227 |
| Reading RSS Feeds..... | 228 |
| Chapter 3: Using FTP | 231 |
| Using Graphical FTP Clients..... | 231 |
| Using the Command-Line FTP Client..... | 236 |
| Chapter 4: Hosting Internet Services | 241 |
| Understanding Internet Services..... | 241 |
| Using the Internet Super Server..... | 247 |
| Running Standalone Servers..... | 250 |
| Chapter 5: Managing Mail and News Servers | 257 |
| Installing the Mail Server..... | 257 |
| Installing the INN Server..... | 268 |
| Configuring and Starting the INN Server..... | 269 |
| Setting Up Local Newsgroups..... | 275 |
| Chapter 6: Managing DNS | 279 |
| Understanding Domain Name System (DNS)..... | 279 |
| Configuring DNS..... | 285 |

Chapter 1: Browsing the Web

In This Chapter

- ✓ **Discovering the web**
- ✓ **Understanding a URL**
- ✓ **Checking out web servers and web browsers**
- ✓ **Taking stock of web browsers for Linux**
- ✓ **Web browsing with Mozilla Firefox**

I suspect you already know about the web or have been living under a rock for a number of years. However, did you know that the web (or more formally, the World Wide Web) made the Internet what it is today? The Internet's been around for quite a while, but it didn't reach the masses until the web came along in 1993.

Before the web was created, you had to use arcane Unix commands to download and use files, which was simply too complicated for most of us. With the web, however, anyone can enjoy the benefits of the Internet by using a *web browser* — a graphical application that downloads and displays web documents. A click of the mouse is all you need to go from reading a document from your company website to downloading a video clip from across the country.

In this chapter, I briefly describe the web and introduce Mozilla Firefox — the primary web browser (and, for that matter, mail and newsreader, too) in most Linux distributions.



There are many other web browsers available and some are included with various distributions, but after you've used one web browser, you can easily use any other web browser.

Discovering the Web

If you've used a file server at work, you know the convenience of sharing files. You can use the word processor on your desktop to get to any document on the shared server.

Now imagine a word processor that enables you to open and view a document that resides on any computer on the Internet. You can view the document in its full glory, with formatted text and graphics. If the document makes a

reference to another document (possibly residing on yet another computer), you can open that linked document simply by clicking the reference. That kind of easy access to distributed documents is essentially what the web provides.

Of course, the documents have to be in a standard format so that any computer (with the appropriate web browser software) can access and interpret the document. And a standard protocol is necessary for transferring web documents from one system to another.



The standard web document format is *HyperText Markup Language* (HTML), and the standard protocol for exchanging web documents is *HyperText Transfer Protocol* (HTTP). HTML documents are text files and don't depend on any specific operating system, so they work on any system from Windows and Mac to any type of Unix and Linux.



A *web server* is software that provides HTML documents to any client that makes the appropriate HTTP requests. A *web browser* is the client software that actually downloads an HTML document from a web server and displays the contents graphically.

Like a giant spider's web

The web is the combination of the web servers and the documents (HTML) that the servers offer. When you look at the web in this way, the web is like a giant book whose pages are scattered throughout the Internet. You use a web browser running on your computer to view the pages — the pages are connected like a giant spider's web, with the documents everywhere.

Imagine that the web pages — HTML documents — are linked by network connections that resemble a giant spider's web, so you can see why the web is called *the web*. The *World Wide* part comes from the fact that the web pages are scattered around the world.

Links and URLs

Like the pages of printed books, web pages contain text and graphics. Unlike printed books, however, web pages can include multimedia, such as video clips, sound, and links to other web pages.

The *links* in a web page are references to other web pages that you can follow to go from one page to another. The web browser typically displays these links as underlined text (in a different color) or as images. Each link is like an instruction to you — something like “For more information, please consult Chapter 4,” as you might find in a book. In a web page, all you have to do is click the link; the web browser brings up the referenced page, even though that document may actually reside on a faraway computer somewhere on the Internet.



The links in a web page are referred to as *hypertext links* because when you click a link, the web browser jumps to the web page referenced by that link.

This arrangement brings up a question. In a printed book, you might ask the reader to go to a specific chapter or page in the book. How does a hypertext link indicate the location of the referenced web page? In the web, each web page has a special name, called a *Uniform Resource Locator (URL)*. A URL uniquely specifies the location of a file on a computer. Figure 1-1 shows the parts of a URL.

Figure 1-1:
The parts of
a Uniform
Resource
Locator
(URL).

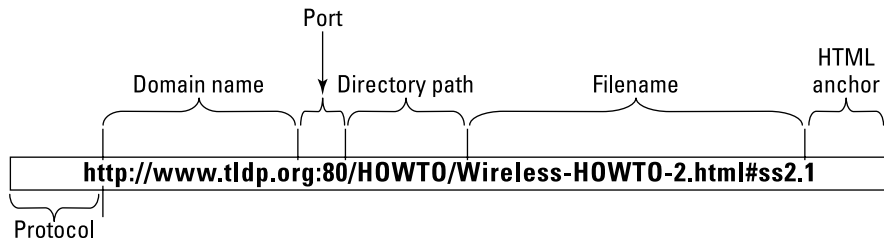

As Figure 1-1 shows, a URL has the following parts:

- ◆ **Protocol:** Name of the protocol that the web browser uses to access the data from the file the URL specifies. In Figure 1-1, the protocol is `http://`, which means that the URL specifies the location of a web page. Here are some of the common protocol types and their meanings:

`file://` means the URL points to a local file. You can use this URL to view HTML files without having to connect to the Internet. For example, `file:///var/www/html/index.html` opens the file `/var/www/html/index.html` from your Linux system.

`ftp://` means that you can download a file using the File Transfer Protocol (FTP). For example, `ftp://ftp.purdue.edu/pub/uns/NASA/nasa.jpg` refers to the image file `nasa.jpg` from the `/pub/uns/NASA` directory of the FTP server `ftp.purdue.edu`. If you want to access a specific user account via FTP, use a URL in the following form:

```
ftp://username:password@ftp.somesite.com/
```

with `username` and `password` embedded in the URL.

The password is in plain text and not secure.

`http://` means that you download the file using the HyperText Transfer Protocol (HTTP). This protocol is the well-known format of URLs for all websites, such as `http://fedoraproject.org` for the Fedora Project's home page. If the URL doesn't have a filename, the web server sends a default HTML file named `index.html`. (That's the default filename for the popular Unix-based Apache web servers; Microsoft Windows web servers use a different default filename.)



`https://` specifies that you access the file through a *Secure Sockets Layer* (SSL) connection — a protocol designed by Netscape Communications for encrypted data transfers across the Internet. Typically, this form of URL is used when the web browser sends sensitive information (such as credit card number, username, and password) to a web server. For example, a URL such as

```
https://some.site.com/secure/takeorder.html
```

may display an HTML form that requests credit card information and other personal information (such as name, address, and phone number).

`mailto:` specifies an e-mail address that you can use to send an e-mail message. This URL opens your e-mail program, from which you can send the message. For example, `mailto:webmaster@someplace.com` refers to the webmaster at the host `someplace.com`.

`news://` specifies a newsgroup that you can read by means of the Network News Transfer Protocol (NNTP). For example:

```
news://news.md.comcast.giganews.com/comp.os.linux.setup
```

accesses the `comp.os.linux.setup` newsgroup at the news server `news.md.comcast.giganews.com`. If you have a default news server configured for the web browser, you can omit the news server's name and use the URL `news:comp.os.linux.setup` to access the newsgroup.

- ◆ **Domain name:** Contains the fully qualified domain name of the computer that has the file this URL specifies. You can also provide an IP address in this field. The domain name is not case-sensitive.
- ◆ **Port:** Port number that is used by the protocol listed in the first part of the URL. This part of the URL is optional; all protocols have default ports. The default port for HTTP, for example, is 80. If a site configures the web server to listen to a different port, the URL has to include the port number.
- ◆ **Directory path:** Directory path of the file referred to in the URL. For web pages, this field is the directory path of the HTML file. The directory path is case-sensitive.
- ◆ **Filename:** Name of the file. For web pages, the filename typically ends with `.htm` or `.html`. If you omit the filename, the web server returns a default file (often named `index.html`). The filename is case-sensitive.
- ◆ **HTML anchor:** Optional part of the URL that makes the web browser jump to a specific location in the file. If this part starts with a question mark (?) instead of a pound sign (#), the browser takes the text following the question mark to be a query. The web server returns information based on such queries.

Web servers and web browsers

The web server serves up the web pages, and the web browser downloads them and displays them to the user. That's pretty much the story with these two cooperating software packages that make the web work.

In a typical scenario, the user sits in front of a computer that's connected to the Internet and runs a web browser. When the user clicks a link or types a URL into the web browser, the browser connects to the web server and requests a document from the server. The web server sends the document (usually in HTML format) and ends the connection. The web browser interprets and displays the HTML document with text, graphics, and multimedia (if applicable).

The web browser's connection to the web server ends after the server sends the document. When the user browses through the downloaded document and clicks another hypertext link, the web browser again connects to the web server named in the hypertext link, downloads the document, ends the connection, and displays the new document. That's how the user can move from one document to another with ease.



A web browser can do more than simply “talk” HTTP with the web server; web browsers can also download documents and files using FTP, and many have integrated mail and newsreaders as well.

Web Browsing in Linux

As web pages become more interactive and complex, web browsing turns into a stimulating, engaging experience. Also, there's always the element of surprise: You can click a link and end up at unexpected web pages. Links are the most curious (and useful) aspect of the web. You can start at a page that shows today's weather, and a click later, you can be reading this week's issue of an online magazine.

Checking out web browsers for Linux

Many Linux distributions come with the Mozilla Firefox web browser. Firefox is Mozilla's improvement on their original browser, an open source version of the venerable Netscape Communicator. Chrome, from Google, is popular as well — and commonly used today. Several others that you might run across, or consider using, are

- ◆ **Epiphany:** A GNOME web browser that uses parts of the Mozilla code to draw the web pages but has a simpler user interface than Mozilla.
- ◆ **Konqueror:** A KDE web browser that can also double as a file manager and a universal viewer.



In addition to dedicated browser applications such as these, many other applications are capable of downloading and displaying web pages.

If your distribution doesn't install Firefox by default, you can easily install it by typing **su** - to become **root** and then typing **apt-get install mozilla-firefox**.

Introducing Firefox's user interface

You can typically start Firefox by clicking an icon on the panel or by choosing Firefox from the GUI desktop's menu.

When Firefox starts, it displays a browser window with a default home page. (The main web page on a web server is the *home page*.) You can configure Firefox to use a different web page as the default home page.

Figure 1-2 shows a web page from a U.S. government website (www.irs.gov), as well as the main elements of the Firefox browser window.

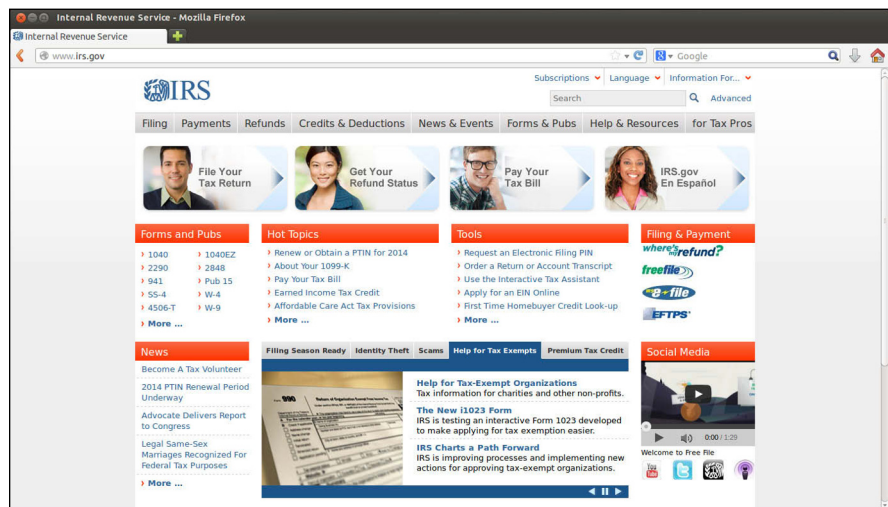

Figure 1-2:
The Firefox web browser in action.



Firefox supports *tabbed browsing*, which means that you can open a new tab (by pressing **Ctrl+T** or clicking the plus sign to the right of the last open tab) and view a web page in that tab. That way you can view multiple web pages in a single window.

The Firefox web browser includes lots of features in its user interface, but you can master it easily. You can start with just the basics to get going with Firefox and then gradually expand to areas that you haven't yet explored.

Firefox toolbars

By default, the standard toolbar is hidden. When the cursor is moved to the upper right, however, the toolbar — and the options associated with the standard menus (File, Edit, and so forth) — appear. You can configure what appears here, but the following is standard.

To start with, here's what you can do with the buttons and text boxes on the Navigation toolbar, from left to right:

- ◆ **Back:** Move to the previous web page.
- ◆ **Forward:** Move to the page from which you have gone backward.
- ◆ **Recent Pages:** Open a drop-down list of recently visited web pages.
- ◆ **Reload:** Reload the current web page.
- ◆ **Stop:** Stop loading the current page.
- ◆ **Home:** Go to the home page.
- ◆ **Location:** Show the URL of the current web page. (Type a URL in this box and press Enter to view that web page.)
- ◆ **Bookmark:** Bookmark the page you are currently viewing. (Click the star icon at the end of the location bar.)
- ◆ **Search:** Search various websites such as Google, Yahoo!, Amazon.com, Dictionary.com, and eBay. (Type text and press Enter to search the currently selected website; the default is Google.)

Status bar

You can think of the bar along the bottom edge of the Firefox window as the status bar because the middle part of that area displays status information while Firefox loads a web page.



In the right corner of Firefox's status bar, a security padlock icon appears when you access a secure website. Firefox supports a secure version of HTTP that uses SSL to transfer encrypted data between the browser and the web server. When Firefox connects to a web server that supports secure HTTP, a locked security padlock icon appears on the right edge of the status bar. Otherwise there's no security padlock icon, an absence that signifies an insecure connection. The URL for secure HTTP transfers begins with `https://` instead of the usual `http://` (note the extra `s` in `https`). You can click the padlock icon for more security information about the page.



Firefox displays status messages in the left part of the status bar. You can watch the messages in this area to see what's going on. If you mouse over a link on the web page, the status bar displays the URL for that link.

Firefox menus

I haven't mentioned the Firefox menus much. That's because you can usually get by without having to go to them. Nevertheless, taking a quick look through the Firefox menus is worthwhile so you know what each one offers. Table 1-1 gives you an overview of the Firefox menus.

| Table 1-1 | Firefox Menus |
|------------------|---|
| <i>Menu</i> | <i>Enables You to Do the Following</i> |
| File | Open a file or web location, open or close a tab, send a web page or link by e-mail, edit a web page, print the current page, import settings and data, and quit Firefox. |
| Edit | Copy and paste selections, find text in the current page, and edit your preferences. |
| View | Show or hide various toolbars, reload the current page, make the text larger or smaller, and view the HTML code for the page. |
| History | Go backward and forward in the list of pages you've visited, or jump to other recently visited web pages. |
| Bookmarks | Bookmark a page, organize the bookmarks, and add links to the Bookmarks toolbar folder. (These links appear in the Bookmarks toolbar.) |
| Tools | Search the web and manage various aspects of the web page, such as themes; view information about the current page; and clear browsing history. |
| Help | Get online help on Firefox. |

Changing your home page

Your home page is the page that Firefox loads when you start it. The default home page depends on the distribution. Often the home page is a file from your system's hard drive. Changing the home page is easy.

First, locate the page on the web that you want to be the home page. You can get to that page any way you want. You can search with a search engine to find the page you want, you can type in the URL in the Location text box,

or you may even accidentally end up on a page that you want to make your home page. It doesn't matter.

When you're viewing the web page that you want to make your home page in Firefox, choose **Edit**→**Preferences** from the Firefox menu. The Preferences dialog box appears, as shown in Figure 1-3.

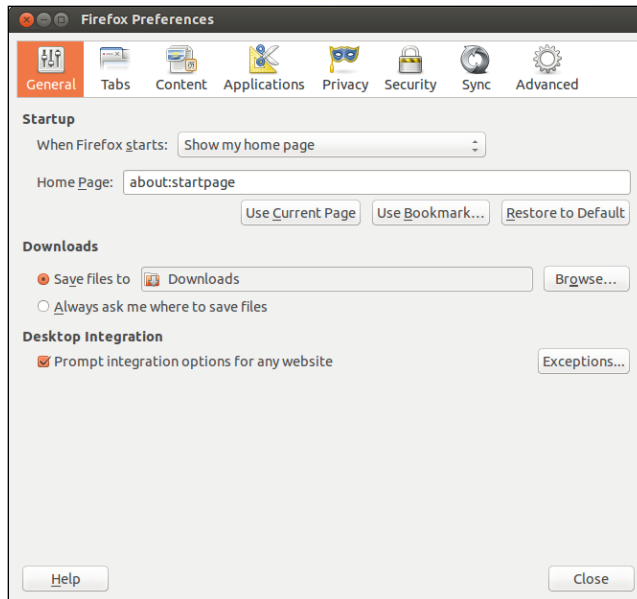

Figure 1-3: Configure the Firefox browser to suit your preferences.

In Figure 1-3, notice the Home Page text box. Below the text box is a Use Current Page button. Click that button to make the current page your home page. If you select this option while multiple tabs are open, the browser will open each tab with every new session.



You can set a lot of other options using the Preferences dialog box. Three sets of options worth noting are those that appear under Content (shown in Figure 1-4), Privacy (shown in Figure 1-5), and Security (shown in Figure 1-6).

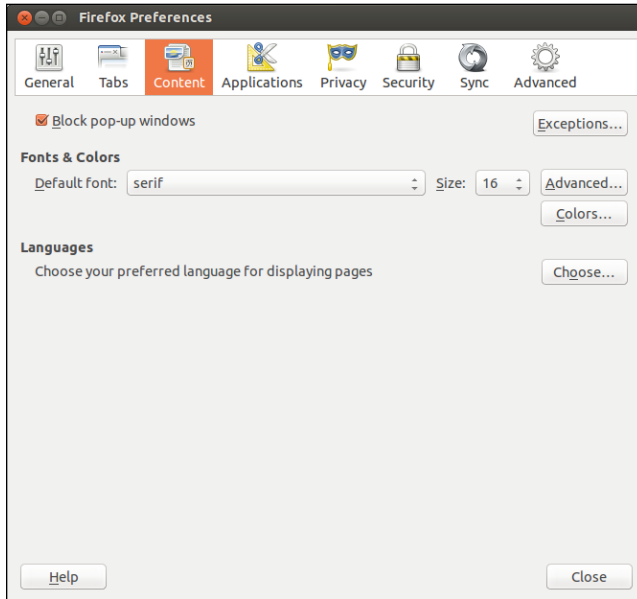

Figure 1-4: You can block pop-ups beneath the Content configuration settings.

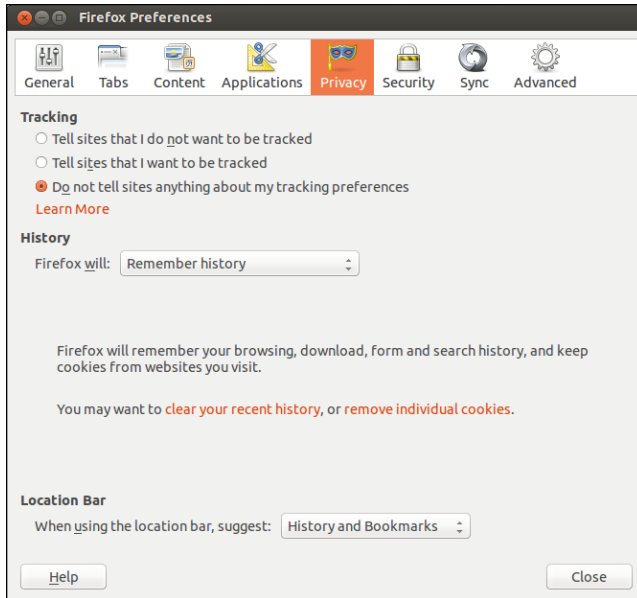
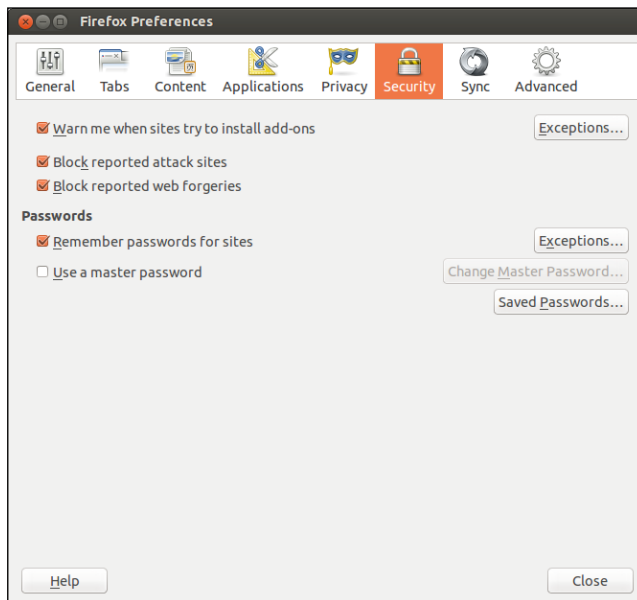

Figure 1-5: You can choose not to be tracked beneath the Privacy configuration settings.

Figure 1-6: Under the Security configuration settings, you can opt for notification each time a site tries to install an add-on.



Although I don't explain all the options here, you can click around to explore everything that you can do from this window. For example, you can click the Use Bookmark button to select a saved URL bookmark as the home page. (You have to select the bookmark from a dialog box.)

Surfing the Internet with Firefox

Where you go from the home page depends on you. All you have to do is click and see where you end up. Move your mouse around. You know when you're on a link because the mouse pointer changes to a hand with an extended index finger. Click the link, and Firefox downloads the web page referenced by that link.

How you use the web depends on what you want to do. When you first get started, you may explore a lot — browsing through websites and following links without any specific goal in mind (what you may call web window-shopping).

The other, more purposeful, use of the web is to find specific information from the Internet. For example, you might want to locate all the websites that contain documents with a specified keyword. For such searches, you can use one of many web search tools available on the Net. Firefox's Search textbox takes you to the Google Web Search page (www.google.com).

A third type of use is a visit to a specific site with a known URL. For example, when reading about a particular topic in this book, you may come across a specific URL. In that case, you want to go directly to that web page.



If you want to surf the Internet with Firefox, all you need is a starting web page — then you can click whatever catches your fancy. For example, select the text in the Location text box in Firefox's Navigation toolbar, type **www.wiley.com**, and then press Enter. You get to the Wiley home page that shows the various imprints (including the Dummies series) that Wiley publishes. There's your starting point. All you have to do is click and you're on your way.

Chapter 2: Reading Newsgroups and RSS Feeds

In This Chapter

- ✓ Finding out about newsgroups
- ✓ Reading a newsgroup
- ✓ Searching newsgroups
- ✓ Reading an RSS feed

Newsgroups were created to provide a distributed conferencing system that spanned the globe. The idea behind them was that you could (and still can) post articles — essentially e-mail messages to an entire group of people — and respond to articles others have posted.

Think of an Internet newsgroup as a gathering place — a virtual meeting place where you can ask questions and discuss various issues. (And best of all, everything you discuss is archived for posterity.) Internet newsgroups are similar to the bulletin board systems (BBSs) of the pre-web age or the forums that you may remember being offered on online systems such as AOL and MSN.

Participation in newsgroups required access to a news server and a news-reader (Linux almost always comes with software that you can use to read newsgroups). While the concepts remain the same, one big change in recent years is that blogs and microblogs have tended to rise in popularity at the expense of newsgroups. Google, through Google Groups, has done a great job of keeping the newsgroups popular.

In this chapter, I introduce you to newsgroups and show you how to read newsgroups with a few of the newsreaders. I also briefly explain how you can read and search newsgroups for free from a few websites.

Nowadays another popular way to read summaries of websites and blogs is to use a program that can accept RSS feeds. At the end of this chapter, I briefly describe what an RSS feed is and how you can use a program such as KDE Akregator to subscribe to RSS feeds and read them on your Linux system.

Understanding Newsgroups

Newsgroups originated in *Usenet* — a store-and-forward messaging network that was widely used for exchanging e-mail and news items. Usenet works like a telegraph by relaying news and mail from one system to another. In Usenet, the systems aren't on any network; the systems simply dial up one another and use the Unix-to-Unix Copy Protocol (UUCP) to transfer text messages.

Although it's a loosely connected collection of computers, Usenet works well — and continues to be used because little expense is involved in connecting to it. All you need is a modem and a site willing to store and forward your mail and news. You have to set up UUCP on your system, but you don't need a sustained network connection; just a few phone calls are all you need to keep the e-mail and news flowing. The downside of Usenet is that you can't use TCP/IP services such as the web, TELNET, or FTP with UUCP.

From their Usenet origins, newsgroups have now migrated to the Internet (even though the newsgroups are still called *Usenet newsgroups*). Instead of UUCP, the Network News Transfer Protocol (NNTP) now transports the news.

Although (for most of the online world) the news transport protocol has changed from UUCP to NNTP, the store-and-forward concept of news transfer remains. Thus, if you want to get news on your Linux system, you have to find a news server from which your system can download news. Typically, you can use your ISP's news server.

Newsgroup hierarchy

The Internet newsgroups are organized in a hierarchy for ease of maintenance as well as ease of use. The newsgroup names help keep things straight by displaying this hierarchy.

Admittedly, these newsgroup names are written in Internet-speak, which can seem obscure at first. But the language is easy to pick up after a little bit of explanation. For example, a typical newsgroup name looks like this:

```
comp.os.linux.announce
```

This is a newsgroup for announcements (*announce*) about the Linux operating system (*os.linux*), and these subjects fall under the broad category of computers (*comp*). As you can see, the format of a newsgroup name is a sequence of words separated by periods. These words denote the hierarchy of the newsgroup. Figure 2-1 illustrates the concept of the hierarchical organization of newsgroups.

Figure 2-1: Newsgroups are organized in a hierarchy with many top-level categories.

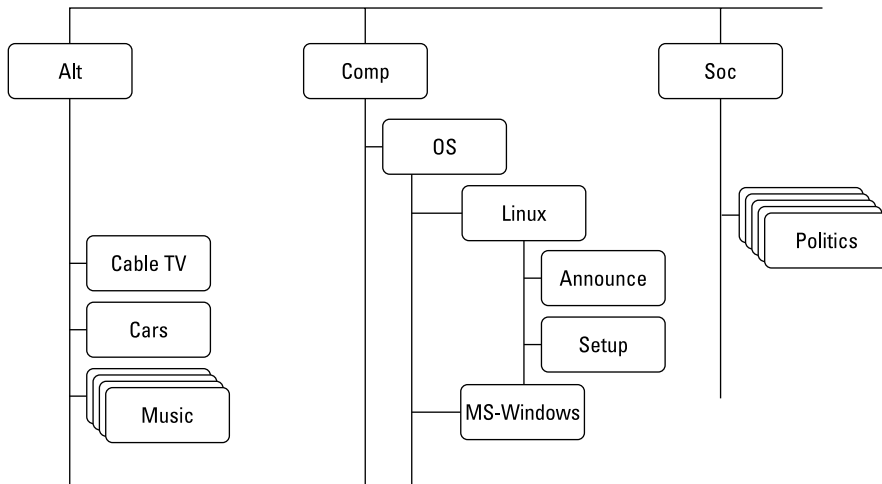

To understand the newsgroup hierarchy, compare the newsgroup name with the pathname of a file (for example, `/usr/lib/X11/xinit/Xclients`) in Linux. Just as a file’s pathname shows the directory hierarchy of the file, the newsgroup name shows the newsgroup hierarchy. In filenames, a slash (/) separates the names of directories; in a newsgroup’s name, a period (.) separates the different levels in the newsgroup hierarchy.

In a newsgroup name, the first word represents the newsgroup *category*. The `comp.os.linux.announce` newsgroup, as mentioned, is in the `comp` category, whereas `alt.books.technical` is in the `alt` category.

Top-level newsgroup categories

Table 2-1 lists some of the major newsgroup categories. You find a wide variety of newsgroups covering subjects ranging from politics to computers. The Linux-related newsgroups are in the `comp.os.linux` hierarchy.

| <i>Category</i> | <i>Subject</i> |
|---------------------|---|
| <code>alt</code> | <i>Alternative</i> newsgroups (not subject to any rules), ranging from the mundane to the bizarre |
| <code>bionet</code> | Biology newsgroups |
| <code>bit</code> | Bitnet newsgroups |

(continued)

Table 2-1 (continued)

| <i>Category</i> | <i>Subject</i> |
|-----------------|--|
| biz | Business newsgroups |
| clari | Clarinet news service (daily news) |
| comp | Computer hardware and software newsgroups (includes operating systems such as Linux and Microsoft Windows) |
| ieee | Newsgroups for the Institute of Electrical and Electronics Engineers (IEEE) |
| k12 | Newsgroups devoted to elementary and secondary education |
| linux | Newsgroups devoted to Linux (includes a <code>linux.redhat</code> hierarchy) |
| misc | Miscellaneous newsgroups |
| news | Newsgroups about Internet news administration |
| rec | Recreational and art newsgroups |
| sci | Science and engineering newsgroups |
| soc | Newsgroups for discussing social issues and various cultures |
| talk | Discussions of current issues (think talk radio) |

This short list of categories is deceptive because it doesn't tell you about the wide-ranging variety of newsgroups available in each category. The top-level categories alone number more than a thousand, but many top-level categories are distributed only in specific regions of the world. Because each newsgroup category contains several levels of subcategories, the overall count of newsgroups is close to 100,000! The `comp` category alone has close to 1,200 newsgroups.

Unfortunately, many newsgroups are flooded with spam — like your e-mail Inbox, only worse because anyone can post anything on a newsgroup. Moderated newsgroups offer some relief. Anyone who wants to post on a *moderated newsgroup* must first submit the article to a moderator — a human being — who then decides whether to post or reject the article. You can reduce the spam overload by browsing moderated newsgroups whenever possible.



To browse newsgroup categories and get a feel for the breadth of topics covered by the newsgroups, visit the Google Groups website at <http://groups.google.com> and click the Browse All of Usenet link. (You will need to click the Browse Group Categories link on the first page.)

Linux-related newsgroups

Typically, you have to narrow your choice of newsgroups according to your interests. If you want to know more about Linux, for example, you can choose one or more of these newsgroups:

- ◆ `comp.os.linux.admin`: Linux system administration (inactive).
- ◆ `comp.os.linux.advocacy`: Linux promotion.
- ◆ `comp.os.linux.announce`: Important announcements about Linux. This newsgroup is moderated, which means you must mail the article to a moderator, who then posts it to the newsgroup if the article is appropriate for the newsgroup.
- ◆ `comp.os.linux.answers`: Questions and answers about Linux. All the Linux HOWTOs are posted in this moderated newsgroup.
- ◆ `comp.os.linux.development`: Current Linux development work.
- ◆ `comp.os.linux.development.apps`: Linux application development.
- ◆ `comp.os.linux.development.system`: Linux operating system development.
- ◆ `comp.os.linux.embedded`: Running the Linux operating system on embedded hardware.
- ◆ `comp.os.linux.hardware`: Linux and various types of hardware.
- ◆ `comp.os.linux.help`: Help with various aspects of Linux (inactive).
- ◆ `comp.os.linux.misc`: Miscellaneous Linux-related topics.
- ◆ `comp.os.linux.networking`: Networking under Linux.
- ◆ `comp.os.linux.portable`: Running the Linux operating system on laptop computers and portable PCs.
- ◆ `comp.os.linux.powerpc`: Running the Linux operating system on PowerPC microprocessors.
- ◆ `comp.os.linux.redhat`: Red Hat Linux-related topics (inactive).
- ◆ `comp.os.linux.setup`: Linux setup and installation.
- ◆ `comp.os.linux.x`: Setting up and running the X Window System under Linux.
- ◆ `comp.os.linux.xbox`: Running Linux on the Xbox video game console.
- ◆ `linux.debian`: Moderated newsgroup about Debian GNU/Linux (inactive).
- ◆ `linux.debian.news`: Moderated newsgroup for news items about Debian GNU/Linux.
- ◆ `linux.redhat`: Red Hat Linux discussions.



You have to be selective about what newsgroups you read because keeping up with all the news is impossible, even in a specific area such as Linux. When you first install and set up Linux, you might read newsgroups such as `comp.os.linux.answers`, `comp.os.linux.setup`, `comp.os.linux.hardware`, and `comp.os.linux.x` (especially if you have problems with X). After you have Linux up and running, you may want to find out about only new things happening in Linux. For such information, read the `comp.os.linux.announce` newsgroup.

Although a number of newsgroups are currently inactive and not being added to, these groups can still be referenced and searched for help with specific questions.

Reading Newsgroups from Your ISP

If you sign up with an ISP for Internet access, it can provide you with access to a news server. Such Internet news servers communicate by using the Network News Transfer Protocol (NNTP). You can use an NNTP-capable newsreader, such as KNode, to access the news server and read selected newsgroups. You can also read news by using Thunderbird. Using a newsreader is the easiest way to access news from your ISP's news server.



My discussion of reading newsgroups assumes that you obtained access to a news server from your ISP. The ISP provides you with the name of the news server and any username and password needed to set up your news account on the newsreader you use.

To read news, you need a *newsreader* — a program that enables you to select a newsgroup and view the items in that newsgroup. You also have to understand the newsgroup hierarchy and naming conventions (which I describe in the “Newsgroup hierarchy” section, earlier in this chapter). In this section, I show you how to read news from a news server.



If you don't have access to newsgroups through your ISP, you can try using one of the many public news servers that are out there. For a list of public news servers, visit Newzbot at www.newzbot.com. At this website, you can search for news servers that carry specific newsgroups.

Taking stock of newsreaders

You can use one of several software packages to download and read newsgroups in Linux. Here are a few major newsreaders:

- ◆ **Thunderbird:** Thunderbird includes the ability to download news from an NNTP server. You can read newsgroups and post items to newsgroups. Xandros uses Thunderbird for mail and news.

- ◆ **KNode:** This is a newsreader for KDE that you can download from knode.sourceforge.net. Debian and SUSE provide KNode as the newsreader.
- ◆ **Pan:** Pan is a GUI newsreader that, according to the developer's website (<http://pan.rebelbase.com>), "attempts to be pleasing to both new and experienced users." You can download Pan for various Linux distributions from <http://pan.rebelbase.com/download>.



If you don't find a newsreader in your Linux system, you can download and install any of these newsreaders easily in any of the Linux distributions. Often, you can locate the download site by a simple search at a search engine — just search for the word *download* followed by the name of the newsreader.

Reading newsgroups with Thunderbird

You can browse newsgroups and post articles from Thunderbird, a mail and newsreader from the Mozilla project.



In many Linux distributions, the mail and news component of Thunderbird may not be installed. In that case, you have to download and install the Thunderbird mail and news component or use another newsreader. To download Thunderbird, visit www.mozillamessaging.com/thunderbird/.

When you're starting to read newsgroups with Thunderbird for the first time, follow these steps to set up the news account:

1. **Choose Newsgroups from the Thunderbird menu.**
A dialog box appears.
2. **In the new screen that appears, fill in your identity information — name and e-mail address (as shown in Figure 2-2). Then click Next to move to the next screen.**
3. **Enter your news server name and click Next.**
4. **Enter a descriptive name of the newsgroup account and click Next.**
5. **Click Finish to complete the newsgroup account setup.**

The new newsgroup account now appears in the list of accounts on the left side of the Thunderbird window, as shown in Figure 2-3. Click the newsgroup account name, and the right side of the window displays the options for the newsgroup account.

Figure 2-2: Thunderbird's Account Wizard guides you through the newsgroup account setup.



Figure 2-3: Thunderbird now displays the newsgroup.

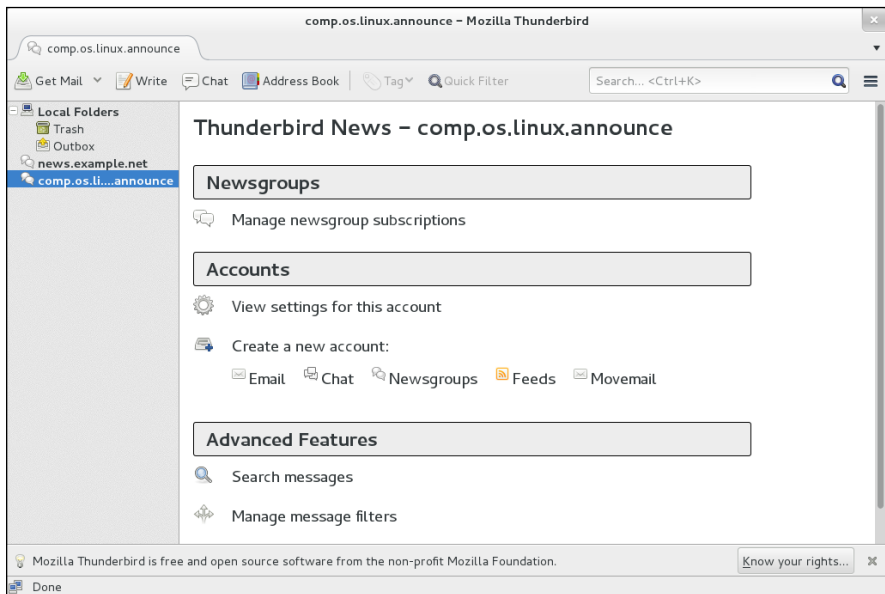



If your ISP's news server requires a username and password, you're prompted for that information. After that, Thunderbird downloads the list of newsgroups and displays them in the Subscribe dialog box. (You can enter a search string in a text box to narrow the list.) When you find the newsgroups you want, click the check box to the right of their names; then click the Subscribe button to subscribe to these newsgroups and click OK to close the dialog box.

After you subscribe to newsgroups, these newsgroups appear under the newsgroup account name on the left side of the Thunderbird window. You can then read a newsgroup using these steps:

1. **Click a newsgroup name (for example, `comp.os.linux.announce`).**
2. **If prompted, enter your username and password.**

Some news servers require a username and password.

3. **Specify the number of headers (for example, 500) you want to download and click Download to proceed.**

Thunderbird downloads the headers from the newsgroup and displays a list in the upper-right area of the window.

4. **From the list of headers, click an item to read that article.**

To select other subscribed newsgroups, simply click the newsgroup's name in the left side of the window.

Newsgroup subscriptions

Unlike magazines or newspapers, newsgroups don't require that you subscribe to them; you can read any available newsgroup on the news server. The news server's administrator may decide to exclude certain newsgroups, however; if they aren't included, you can't read them.

The only thing that can be called *subscribing* is indicating the newsgroups you routinely want to read. The news server doesn't receive any of this subscription information — the information is used only by the newsreader to determine what to download from the news server.

Posting news

You can use any newsreader to post a news article (a new item or a reply to an old posting) to one or more newsgroups. The command for posting a news item depends on the newsreader. For example, in the Thunderbird newsreader, you follow these steps to post an article:

1. **Click the Reply button on the toolbar to post a follow-up to a news item you're reading. To post a new news article, click the Write button.**

A window appears where you can compose the message.

2. **Type the names of the newsgroups, just as you'd type the addresses of recipients when sending e-mail. Enter the subject and your message.**

For this test posting, type **ignore** as the subject line and enter **misc.test** as the name of the newsgroup. Otherwise, any site that receives your article replies by mail to tell you the article has reached the site; that's in keeping with the purpose of the `misc.test` newsgroup.

3. **After you finish composing the message, click Send on the toolbar.**

Thunderbird sends the message to the news server, which in turn sends it to other news servers, and soon it's all over the world!

4. **To verify that the test message reaches the newsgroup, choose File⇨ Subscribe. Then subscribe to `misc.test` newsgroup (that's where you recently posted the new article).**

To subscribe, click the check box to the right of the group name and then click the Subscribe button.

5. **Look at the latest article or one of the most recent ones in `misc.test` to find the article you recently posted.**

If you post an article and read the newsgroup immediately, you see the new article, but that doesn't mean the article has reached other sites on the Internet. After all, your posting shows up on your news server immediately because that's where you posted the article. Because of the store-and-forward model of news distribution, the news article gradually propagates from your news server to others around the world.



The `misc.test` newsgroup provides a way to see whether your news posting is getting around. If you post to that newsgroup and don't include the word *ignore* in the subject, news servers acknowledge receipt of the article by sending an e-mail message to the address listed in the Reply To field of the article's header.

Using KNode

Debian and SUSE provide KNode as the default newsreader. Typically, you can start KNode by selecting Newsreader from the menu (look in the Internet applications); or choose Applications⇨Internet⇨KNode. If you don't see a choice for Newsreader or KNode in the menus, type **knode** in a terminal window to start KNode.

When KNode runs for the first time, it displays the Configure KNode dialog box through which you can configure everything you need to read newsgroups and post items to newsgroups.

The left side of the dialog box displays all the items that you can configure, and the right side is where you enter the information for the item that you've selected on the left.

When the Configure KNode dialog box first opens, it prompts for your personal information. Enter your identification information, such as name, e-mail address, and organization — this information is used when you post a new item to a newsgroup.

Next, click Accounts on the left side and then click the Newsgroup Servers tab on the right side to set up information about the news server from which you'll be reading news. Click Add in the Newsgroup Servers tab to display the dialog box where you can enter the information about the news server. Your ISP should have provided you with the information needed to access the news server. If the news server requires a login name and a password, you must enter that information as well.

After you set up the news account, the KNode window shows the name of the news server on the left. Right-click the server's name and choose Subscribe to Newsgroups from the pop-up menu. A dialog box appears where you can subscribe to selected newsgroups (such as `comp.os.linux.announce`). The first time you access this menu, the list of newsgroups must be fetched. The KNode user interface is similar to many other mail and newsreaders, including Thunderbird.

Reading and Searching Newsgroups at Websites

If you don't have access to newsgroups through your ISP, you can still read newsgroups and post articles to newsgroups at a number of websites. Some of them archive old news articles and provide good search capabilities, so you can search these sites for articles related to some question you may have.

The best parts about reading newsgroups through a website is that you don't even need access to a news server and you can read news from your web browser.

Table 2-2 lists websites that offer free access to Usenet newsgroups. To get a list of all websites that offer newsgroup access (including the ones that charge a fee), use Google (www.google.com) and type the search words **usenet newsgroup access**.

| <i>Website</i> | <i>URL</i> |
|-----------------|---|
| Google Groups | http://groups.google.com |
| InterBulletin | http://news.interbulletin.com |
| Usenet Replayer | www.usenet-replayer.com |

One of the best places to read newsgroups, post articles, and search old newsgroup archives is Google Groups (Google's Usenet discussion forums) on the web at <http://groups.google.com>. At that website, you can select a newsgroup to browse and post replies to articles posted on various newsgroups.

The best part of Google Groups is the search capability. You already know how good Google's web search is; you get that same comprehensive search capability to locate newsgroup postings that relate to your search words. To search newsgroups, fill in the search form at <http://groups.google.com> and press Enter.

To browse newsgroups in Google Groups, ignore the search box and look at the list of high-level newsgroup categories such as `alt`, `comp`, and `soc`. Click the category, and you can gradually drill down to specific newsgroups. When viewing an article in Google Groups, you can click a link that enables you to post a follow-up to that article.

Reading RSS Feeds

RSS stands for Really Simple Syndication. RSS is a format for *syndicating* — gathering and making available — the content of websites, primarily news-oriented sites and blogs. The term *blog* is short for weblog — a frequently updated journal with thoughts, comments, and opinions of the blog's creator. RSS can be used to provide any kind of information that can be broken down into discrete items and put into RSS format. Such RSS-formatted content is an *RSS feed*, and an RSS-aware program can check the feed periodically for changes, download new items, and make them available to the user.

The RSS format is a dialect of XML (eXtensible Markup Language). All RSS files conform to XML 1.0 specification.



Many versions of RSS are available, but three versions — 0.91, 1.0, and 2.0 — are in widespread use. Netscape designed RSS version 0.90 for gathering and displaying headlines from news sites. A simpler version, 0.91, was proposed, and UserLand Software picked up that version for use in its blogging product. At the same time, another noncommercial group had evolved RSS 0.90 into RSS 1.0, which is based on resource description format, or RDF (see www.w3.org/rdf). UserLand didn't accept RSS 1.0 but instead continued evolving RSS 0.91 through versions 0.92, 0.93, and 0.94 and finally settled on RSS 2.0 (skipping 1.0 because that version number was already taken). Currently, many blogs and websites use RSS 0.91 for basic syndication (title, URL, and description), RSS 1.0 for readers that use RDF, and RSS 2.0 for advanced syndication with more metadata. (Think of metadata as *data about data*, which is what the RSS format provides: It provides data about other information, such as blogs and news.) RSS 1.0 files have an `.rdf` extension, whereas RSS 0.91 and 2.0 files have an `.xml` extension. However, all RSS files are text files that use XML tags.

Examining an RSS Feed

An RSS feed is a text file with XML tags that describe a website's content. You typically use an automated program to periodically generate the RSS feed file, but you can prepare the RSS feed file using a text editor. It's good to know what an RSS feed looks like, just so you can debug problems with the feed.

The specific details of an RSS feed depend on the version of RSS. The simplest feed is RSS 0.91, and here's a typical RSS 0.91 feed:

```
<?xml version="1.0" ?>
<!-- A comment line --->
<rss version="0.91">

<channel> <!-- This tag specifies general information about
the feed--->
<title>Title of this feed</title>
<link>URL of this feed, for example, http://edulaney.typepad.
com/</link>
<description>Brief description of feed</description>
<language>en-us</language>
<item>
<title>Title of this item</title>
<link>URL for this item</link>
<description>Description of this item</description>
</item>
. . . more items . . .
</channel>
</rss>
```

As you can see from that listing, an RSS feed includes a channel with a title, link, description, and language followed by a series of items, each of which has a title, link, and description.

The format is more verbose for RSS 1.0, which uses the RDF format. RSS 1.0 essentially provides the basic information that's in RSS 0.91 and adds more details such as item-level authors, subject, and publishing dates, which RSS 0.91 doesn't support.



Reading RSS Feeds

Many GUI programs are available for subscribing to RSS feeds and reading items from a feed. These programs are RSS *aggregators* because they can gather information from many RSS feeds and make everything available in a single place.

The two types of RSS aggregators are web browser plug-ins and standalone programs. Browser plug-ins, such as NewsMonster (www.newsmonster.org), run in a web browser so that the feeds appear in the web browser. Standalone programs such as GNOME Straw (<http://projects.gnome.org/straw>) and KDE Akregator (<http://akregator.kde.org>) are complete GUI applications and usually look similar to other mail and newsreader programs.



Fedora and SUSE come equipped with the Akregator program, a standalone RSS feed aggregator. To run it, look for a link in the GUI desktop's applications menu (choose Application→Internet→Akregator). If you don't see Akregator listed, type **akregator** in a terminal window. In Debian, you can install Akregator by typing **apt-get install akregator** (after typing **su** - to become `root`).

When Akregator first runs, it displays its main window without any RSS feeds. To subscribe to a feed, choose Feed→Add Feed from the menu or right-click All Feeds in the left pane of the window and select Add Feed from the pop-up menu. Then type the URL for the feed in the Add Feed dialog box and click OK. For example, to read Slashdot's RSS feed, type `http://slashdot.org/index.rss`. The feed's title appears in the left pane of the window. Click the feed title to view the items in this feed. Then you can click an item in the upper-right pane, and that item appears in the lower-right pane. You can add many different RSS feeds, organize them into folders, and browse them in Akregator.

Chapter 3: Using FTP

In This Chapter

- ✓ Using an FTP client
- ✓ Using any web browser as an FTP client
- ✓ Getting to know the FTP commands

Just as the name implies, *File Transfer Protocol* (FTP) is used to transfer files between computers. For example, if your Internet service provider (ISP) gives you space for a personal website, you may have already used FTP to upload the files making up the website. Using an FTP client on your computer, you log in to your ISP account, provide your password, and then copy the files from your home system to the ISP's server.

You can also use FTP to download other files anonymously, such as open source software from other computers on the Internet — in which case, you don't need an account on the remote system to download files. You can simply log in using `anonymous` as the username and provide your e-mail address as the password. (In fact, your web browser can do this on your behalf, so you may not even know this process is happening.) This type of *anonymous FTP* is great for distributing files to anyone who wants them. For example, a hardware vendor might use anonymous FTP to provide updated device drivers to anyone who needs them.

Linux comes with several FTP clients, both command-line ones and GUI (graphical user interface) ones. This chapter introduces you to a few GUI FTP clients and a command-line FTP client. It also describes the commands you use to work with remote directories.



Depending on your Linux distribution and version, you may need to install the FTP clients discussed in this chapter.

Using Graphical FTP Clients



You can use one of the following GUI FTP clients in Linux:

- ◆ **gFTP:** A graphical FTP client for GNOME at <http://gftp.seul.org>.
- ◆ **FileZilla:** A graphical FTP client for Linux and Windows platforms at <https://filezilla-project.org>.
- ◆ **Web browser:** A browser such as Firefox, for anonymous FTP downloads

For uploading files, you may want to use gFTP or FileZilla because typically you have to provide a username and password for such transfers. Web browsers work fine for anonymous downloads, which is how you typically download software from the Internet.

All three GUI FTP clients are discussed in the next three sections.

Using gFTP

Some versions of GNOME come with gFTP, a graphical FTP client. gFTP isn't installed by default, but you can download it from <http://gftp.seul.org> and install it easily. In some distributions, gFTP may be included in a package already, and you just have to install that package.



gFTP has not been updated for several years, but is still widely used and that speaks to its robustness and suitability for the job.

Start gFTP, once it is installed, in the main menu, application window, or search and the gFTP window appears, similar to that shown in Figure 3-1.

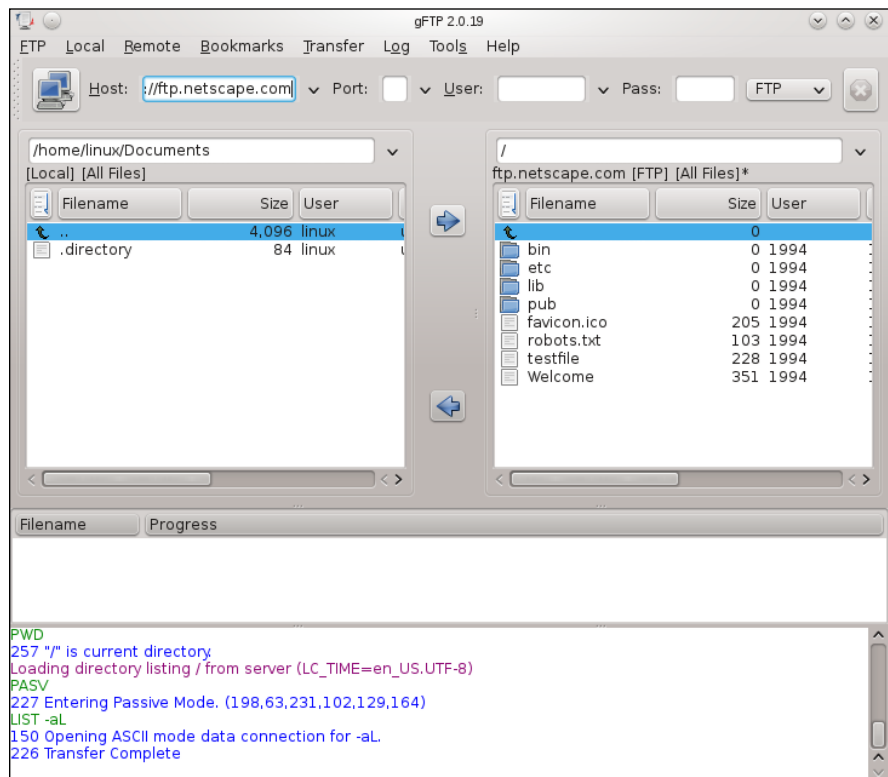

Figure 3-1: The gFTP window just after opening a connection to an FTP server.

The gFTP window has a menu bar with menus for performing various tasks. Just below the menu bar is a toolbar with a number of buttons and text fields. Here you can type the name or IP address of the remote host, and the username and password needed to log in to the remote host. Figure 3-1 shows the gFTP window after you fill in this information and establish a connection with the remote host by clicking the button with the icon showing two computers (the leftmost one on the toolbar).

To upload or download files with gFTP, follow these steps:

1. Fill in the hostname or the IP address of the remote system in the Host field.

If you've used that host before, you can select it from the drop-down list that appears when you click the downward-pointing arrow next to the Host field.

2. Provide the username in the User field and the password in the Pass field, and then click the button with the icon showing two computers (to the left of the Host field).

This operation causes gFTP to connect to your chosen host and to log in with the username and password you provided. The lower part of the gFTP window shows the FTP protocol messages exchanged between the two systems.

3. Observe the lower part of the screen for any indication of error messages.

The directory listing of the remote system appears in the right half of the gFTP window. The left half shows the current local directory.

4. To upload one or more files from the current system to the remote system, select the files in the list on the left and then click the right-pointing arrow button.

5. To download files from the remote system, select the filenames in the list on the right and click the left-pointing arrow button.

6. When you've finished transferring files, choose FTP⇄Quit.

As these steps show, transferring files with a GUI FTP client, such as gFTP, is simple.

Believe it or not, gFTP isn't for FTP transfers alone. It can also transfer files using the HTTP (HyperText Transfer Protocol) and do secure file transfers using the Secure Shell (SSH) protocol.



Introducing FileZilla

FileZilla is another GUI FTP client for both Windows and Linux. It's very similar to gFTP, but its development continues (whereas development has stopped on gFTP). The two programs are similar in look and operations. You find FileZilla at <https://filezilla-project.org> (as shown in Figure 3-2). It works on all distributions, and in both GNOME and KDE.

Figure 3-2:
Download
FileZilla
from the
site.

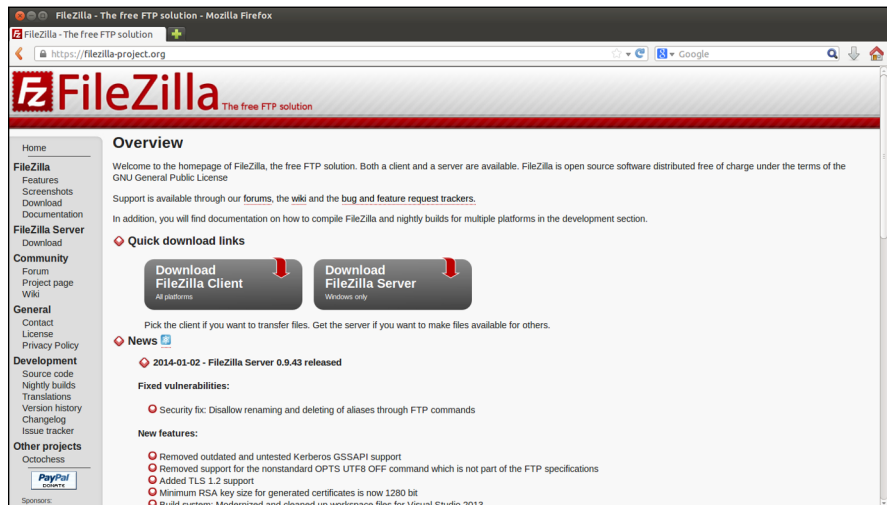

When the main FileZilla window appears, it displays your home folder in a view similar to that in Windows Explorer. To connect to an FTP server, type the name or IP address of the remote host, and the username and password needed to log in to the remote host. Figure 3-3 shows the FileZilla window after you fill in this information and establish a connection with the remote host.

You can now upload or download files with FileZilla just as you would gFTP,

FTP transfers become just normal drag-and-drop file copying: Transfer files by simply dragging them from one system's folder and dropping them on the other system's folder.

When you finish, choose File⇒Quit.

Using a web browser as an FTP client

Any web browser can act as an FTP client, but such programs are best for anonymous FTP downloads, where the web browser can log in using the anonymous username and any password.

Figure 3-3:
FileZilla
window
displays the
local
directory
and the
remote FTP
server's
directory.

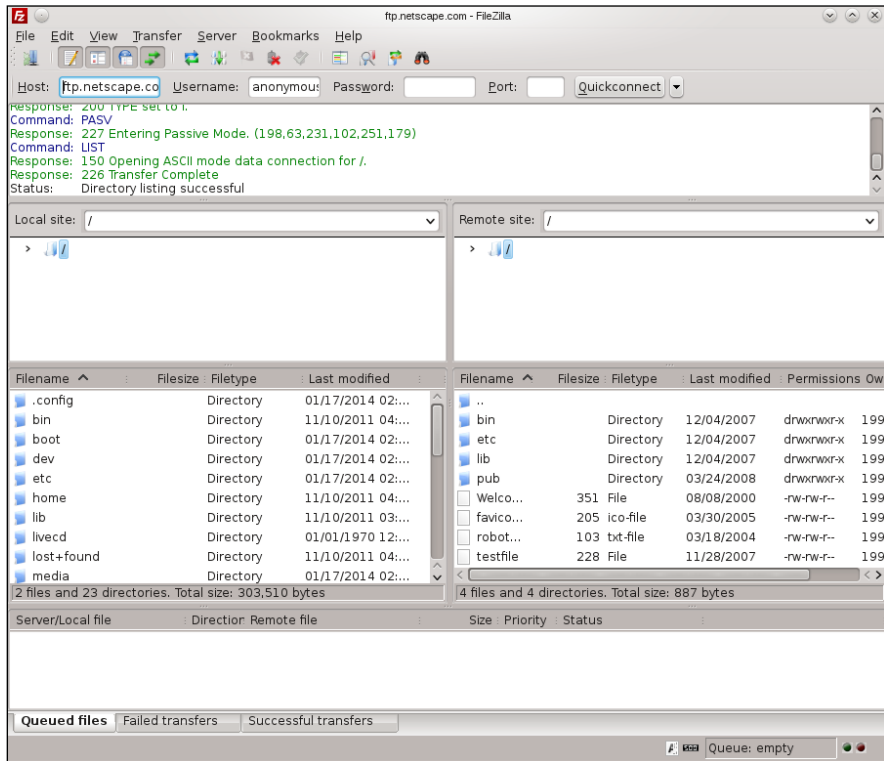

For example, you can use the Firefox web browser as an FTP client. All you have to know is how to write the URL so that the web browser can tell that you want to download a file using FTP. The syntax of the FTP URL is

```
ftp://hostname/pathname
```

The first part (`ftp://`) indicates that you want an FTP transfer. The *hostname* part is the name of the FTP server (the name often starts with `ftp` — for example, `ftp.wiley.com`). The *pathname* is the full directory path and filename of the file that you want to download.

If you simply provide the hostname for the FTP server, the web browser displays the contents of the anonymous FTP directory. If you want to access anonymous FTP on your Linux system, start Firefox (click the web browser icon on the GNOME panel), type the FTP URL in the Location text box, and press Enter.

Figure 3-4 shows a typical appearance of an FTP directory in Firefox. You can click folders to see their contents and download any files. You can access your local system by using Firefox's FTP capabilities; for example, type

`ftp://localhost/pub/` to access the `pub` directory. (You won't get a response from your system if you're not running an FTP server or if you've set up your firewall so that no FTP connections are allowed.)

Figure 3-4:
You can use a web browser to download files from FTP servers.

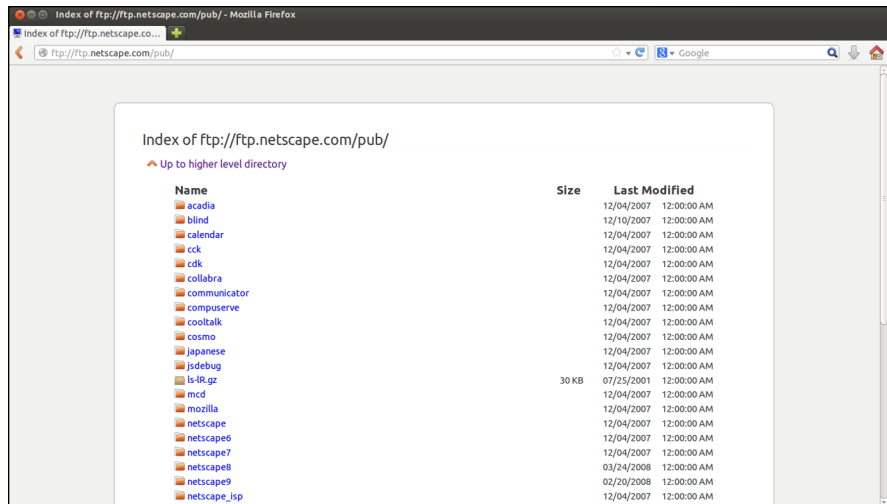

In Debian and Fedora, log in as `root` and type `/etc/init.d/vsftpd start` (in a terminal window) to start the FTP server. In SUSE, the `xinetd` super server controls the FTP server `vsftpd`. The `/etc/xinetd.d/vsftpd` configuration file specifies how `vsftpd` is started. (See Book VII, Chapter 1 for more information about `xinetd` configuration files.)

The same approach of accessing anonymous FTP sites works if you type the hostname of some other anonymous FTP server. For example, try typing the following URL:

```
ftp://ftp.netscape.com/
```

You get the directory of the `ftp.netscape.com` server.

Using the Command-Line FTP Client



Knowing how to use FTP from the command line is a good idea. For example, if your GUI desktop isn't working, you may need to download some files to fix the problem; you can do so if you know how to use the command-line FTP client. The command-line FTP client is available in all Linux distributions and using it isn't difficult.

The best way to figure out the command-line FTP client is to try it out. The command is `ftp`, and you can try out the `ftp` commands from your Linux system. You don't even need an Internet connection because you can use the `ftp` command to connect to your own system.



Note that the output from the `ftp` command might be different because some distributions, such as Debian, use a text mode version of `gFTP` as the command-line FTP client.

In the following sample FTP session, the command-line FTP client was used to log in and browse the directories on a Linux system. Here's the listing illustrating interaction with a typical command-line FTP client:

```
ftp localhost
Connected to localhost.localdomain.
220 (vsFTPD 2.0.3)
Name (localhost:jdoo): (press Enter.)
331 Please specify the password.
Password: (enter the password for the user.)
230 Login successful.
Remote system type is Unix.
Using binary mode to transfer files.
ftp> help
Commands may be abbreviated. Commands are:
! debug mdir qc send
$ dir mget sendport site
account disconnect mkdir put size
append exit mls pwd status
ascii form mode quit struct
bell get modtime quote system
binary glob mput recv sunique
bye hash newer reget tenex
case help nmap rstatus tick
cd idle nlist rhelp trace
cdup image ntrans rename type
chmod lcd open reset user
close ls prompt restart umask
cr macdef passive rmdir verbose
delete mdelete proxy runique ?
ftp> help mget (to get help on a specific command.)
mget get multiple files
ftp> cd /var (This changes directory to /var.)
250 Directory successfully changed.
ftp> ls (This command lists the contents of the directory.)
227 Entering Passive Mode (127,0,0,1,38,142)
150 Here comes the directory listing.
. . . lines deleted . . .
226 Directory send OK.
ftp> bye (This command ends the session.)
```

As the listing shows, you can start the command-line FTP client by typing the command **ftp *hostname***, where *hostname* is the name of the system you want to access. When the FTP client establishes a connection with the FTP server at the remote system, the FTP server prompts you for a username and password. After you supply the information, the FTP client displays the `ftp>` prompt, and you can begin typing commands to perform specific tasks. If you can't remember a specific FTP command, type **help** to view a list of them. You can get additional help for a specific command by typing **help *command***, where *command* is the command for which you want help.

Many FTP commands are similar to the Linux commands for navigating the file system. For example, `cd` changes directory, `pwd` prints the name of the current working directory, and `ls` lists the contents of the current directory. Two other common commands are `get` and `put`: `get` is what downloads a file from the remote system to your system, and `put` uploads (sends) a file from your system to the remote host.



Table 3-1 describes some commonly used FTP commands. You don't have to type the entire FTP command. For a long command, you have to type only the first few characters — enough to identify the command uniquely. For example, to delete a file, you can type **dele**, and to change the file transfer mode to binary, you can type **bin**.

Table 3-1 Common FTP Commands

| <i>Command</i> | <i>Description</i> |
|---------------------|--|
| ! | Executes a shell command on the local system. For example, <code>!ls</code> lists the contents of the current directory on the local system. |
| ? | Displays a list of commands (same as <code>help</code>). |
| <code>append</code> | Appends a local file to a remote file. |
| <code>ascii</code> | Sets the file transfer type to ASCII (or plain text). This command is the default file transfer type. |
| <code>binary</code> | Sets the file transfer type to binary. |
| <code>bye</code> | Ends the FTP session with the remote FTP server and quits the FTP client. |
| <code>cd</code> | Changes the directory on the remote system. For example, <code>cd /pub/Linux</code> changes the remote directory to <code>/pub/Linux</code> . |
| <code>chmod</code> | Changes the permission settings of a remote file. For example, <code>chmod 644 index.html</code> changes the permission settings of the <code>index.html</code> file on the remote system. |
| <code>close</code> | Ends the FTP session with the FTP server and returns to the FTP client's prompt. |

| Command | Description |
|-------------------------|---|
| <code>delete</code> | Deletes a remote file. For example, <code>delete bigimage.jpg</code> deletes that file on the remote system. |
| <code>dir</code> | Lists the contents of the current directory on the remote system. |
| <code>disconnect</code> | Ends the FTP session and returns to the FTP client's prompt. (This command is the same as <code>close</code> .) |
| <code>get</code> | Downloads a remote file. For example, <code>get junk.tar.gz junk.tgz</code> downloads the file <code>junk.tar.gz</code> from the remote system and saves it as the file <code>junk.tgz</code> on the local system. |
| <code>hash</code> | Turns on or off the hash mark (#) printing that shows the progress of the file transfer. When this feature is turned on, a hash mark prints onscreen for every 1,024 bytes transferred from the remote system. (It's the command-line version of a progress bar.) |
| <code>help</code> | Displays a list of commands. |
| <code>image</code> | Same as <code>binary</code> . |
| <code>lcd</code> | Changes the current directory on the local system. For example, <code>lcd/var/ftp/pub</code> changes the current local directory to <code>/var/ftp/pub</code> . |
| <code>ls</code> | Lists the contents of the current remote directory. |
| <code>mdelete</code> | Deletes multiple files on a remote system. For example, <code>mdelete *.jpg</code> deletes all remote files with names ending in <code>.jpg</code> in the current directory. |
| <code>mdir</code> | Lists multiple remote files and saves the listing in a specified local file. For example, <code>mdir /usr/share/doc/w* wlist</code> saves the listing in the local file named <code>wlist</code> . |
| <code>mget</code> | Downloads multiple files. For example, <code>mget *.jpg</code> downloads all files with names ending in <code>.jpg</code> . If the prompt is turned on, the FTP client asks for confirmation before downloading each file. |
| <code>mkdir</code> | Creates a directory on the remote system. <code>mkdir images</code> creates a directory named <code>images</code> in the current directory on the remote system. |
| <code>mls</code> | Same as <code>mdir</code> . |
| <code>mput</code> | Uploads multiple files. For example, <code>mput *.jpg</code> sends all files with names ending in <code>.jpg</code> to the remote system. If the prompt is turned on, the FTP client asks for confirmation before sending each file. |

(continued)

Table 3-1 (continued)

| <i>Command</i> | <i>Description</i> |
|---------------------|--|
| <code>open</code> | Opens a connection to the FTP server on the specified host. For example, <code>open ftp.netscape.com</code> connects to the FTP server on the host <code>ftp.netscape.com</code> . |
| <code>prompt</code> | Turns the prompt on or off. When the prompt is on, the FTP client prompts you for confirmation before downloading or uploading each file during a multiple-file transfer. |
| <code>put</code> | Sends a file to the remote system. For example, <code>put index.html</code> sends the <code>index.html</code> file from the local system to the remote system. |
| <code>pwd</code> | Displays the full pathname of the current directory on the remote system. When you log in as a user, the initial current working directory is your home directory. |
| <code>quit</code> | Same as <code>bye</code> . |
| <code>recv</code> | Same as <code>get</code> . |
| <code>rename</code> | Renames a file on the remote system. For example, <code>rename old.html new.html</code> renames the file <code>old.html</code> to <code>new.html</code> on the remote system. |
| <code>rmdir</code> | Deletes a directory on the remote system. For example, <code>rmdir images</code> deletes the <code>images</code> directory in the current directory of the remote system. |
| <code>send</code> | Same as <code>put</code> . |
| <code>size</code> | Shows the size of a remote file. For example, <code>size bigfile.tar.gz</code> shows the size of that remote file. |
| <code>status</code> | Shows the current status of the FTP client. |
| <code>user</code> | Sends new user information to the FTP server. For example, <code>user jdoe</code> sends the username <code>jdoe</code> ; the FTP server then prompts for the password for that username. |



When downloading files from the Internet, you almost always want to transfer the files in binary mode because the software is usually archived and compressed in a binary form. (Its files aren't plain text files.) So always use the `binary` command to set the mode to binary. Then use the `get` command to download the files.



When transferring multiple files with similar names (such as `image1.jpg`, `image2.jpg`, and so on), type **`prompt`** to turn off prompting. (Otherwise the FTP client will ask you after each file transfer whether you want to transfer the next file.) Then type **`mget`** followed by the filename with a wildcard character. For example, to download all files with names starting with `image` and ending with the `.jpg` extension, type **`mget image*.jpg`**.

Chapter 4: Hosting Internet Services

In This Chapter

- ✓ Finding out about Internet services
- ✓ Controlling servers through `inetd` or `xinetd`
- ✓ Using `chkconfig` or `update-rc.d` to manage servers
- ✓ Using GUI utilities to configure services to start at boot time

The Internet is a world of clients and servers. Clients make requests to servers, and servers respond to the requests. For example, your web browser is a client that downloads information from web servers and displays it to you. Of course, the clients and servers are computer programs that run on a wide variety of computers. A Linux system is an ideal system to run different types of servers — from a web server to a Windows file and print server. This chapter provides an overview of a typical Internet service and its client/server architecture, and discusses how to manage the servers in Linux. You can use the information in this chapter to manage any server running on your Linux system.

Understanding Internet Services

Internet services are network applications designed to deliver information from one system to another. By design, each Internet service is implemented in two parts — a *server* that provides information and one or more *clients* that request information.

Such a *client/server* architecture is the most common way to build distributed information systems. The clients and servers are computer programs that run on these computers and communicate through the network. The neat part is that you can run a client at your desktop computer and access information from a server running on a computer anywhere in the world (as long as it's on the Internet).

The web itself, e-mail, and FTP (File Transfer Protocol) are examples of Internet services that use the client/server model. For example, when you use the web, you use the web browser client to download and view web pages from the web server.



Client/server architecture requires clients to communicate with the servers. That's where the *Transmission Control Protocol/Internet Protocol* — TCP/IP — comes in. TCP/IP provides a standard way for clients and servers to exchange packets of data. The next few sections explain how TCP/IP-based services communicate.

TCP/IP and sockets

Client/server applications such as the web and FTP use TCP/IP for data transfers between client and server. These Internet applications typically use TCP/IP communications utilizing the *Berkeley sockets interface* (so named because the socket interface was introduced in Berkeley Unix around 1982). The sockets interface is nothing physical — it's simply some computer code that a computer programmer can use to create applications that can communicate with other applications on the Internet.



Even if you don't write network applications using sockets, you may have to use or set up many network applications. Knowledge of sockets can help you understand how network-based applications work, which in turn helps you find and correct any problems with these applications.

Socket definition

Network applications use sockets to communicate over a TCP/IP network. A *socket* represents one end-point of a connection. Because a socket is bidirectional, data can be sent as well as received through it. A socket has three attributes:

- ◆ The *network address* (the IP address) of the system
- ◆ The *port number*, identifying the process (a *process* is a computer program running on a computer) that exchanges data through the socket
- ◆ The *type of socket*, identifying the protocol for data exchange

Essentially, the IP address identifies a computer (host) on the network; the port number identifies a process (server) on the node; and the socket type determines the manner in which data is exchanged — through a connection-oriented (stream) or connectionless (datagram) protocol.

Connection-oriented protocols

The socket type indicates the protocol being used to communicate through the socket. A connection-oriented protocol works like a normal phone conversation. When you want to talk to your friend, you have to dial your friend's phone number and establish a connection before you can have a conversation. In the same way, connection-oriented data exchange requires both the sending and receiving processes to establish a connection before data exchange can begin.

In the TCP/IP protocol suite, TCP — *Transmission Control Protocol* — supports a connection-oriented data transfer between two processes running on two computers on the Internet. TCP provides reliable two-way data exchange between processes.

As the name TCP/IP suggests, TCP relies on IP — *Internet Protocol* — for delivery of packets. IP does not guarantee delivery of packets; nor does it deliver packets in any particular sequence. IP does, however, efficiently move packets from one network to another. TCP is responsible for arranging the packets in the proper sequence, detecting whether errors have occurred, and requesting retransmission of packets in case of an error.

TCP is useful for applications intended to exchange large amounts of data at a time. In addition, applications that need reliable data exchange use TCP. (For example, FTP uses TCP to transfer files.)

In the sockets model, a socket that uses TCP is referred to as a *stream socket*.

Connectionless protocols

A *connectionless* data-exchange protocol does not require the sender and receiver to explicitly establish a connection. It's like shouting to your friend in a crowded room — you can't be sure that your friend hears you.

In the TCP/IP protocol suite, the *User Datagram Protocol* (UDP) provides connectionless service for sending and receiving packets known as *datagrams*. Unlike TCP, UDP does not guarantee that datagrams ever reach their intended destinations. Nor does UDP ensure that datagrams are delivered in the order they're sent.

UDP is used by applications that exchange small amounts of data at a time or by applications that don't need the reliability and sequencing of data delivery. For example, SNMP (Simple Network Management Protocol) uses UDP to transfer data.

In the sockets model, a socket that uses UDP is referred to as a *datagram socket*.

Sockets and the client/server model

Two sockets are needed to complete a communication path. When two processes communicate, they use the client/server model to establish the connection. (Figure 4-1 illustrates the concept.) The server application listens on a specific port on the system — the server is completely identified by the IP address of the system where it runs and the port number where it listens for connections. The client initiates a connection from any available port and tries to connect to the server (identified by the IP address and port number). When the connection is established, the client and the server can exchange data according to their own protocol.

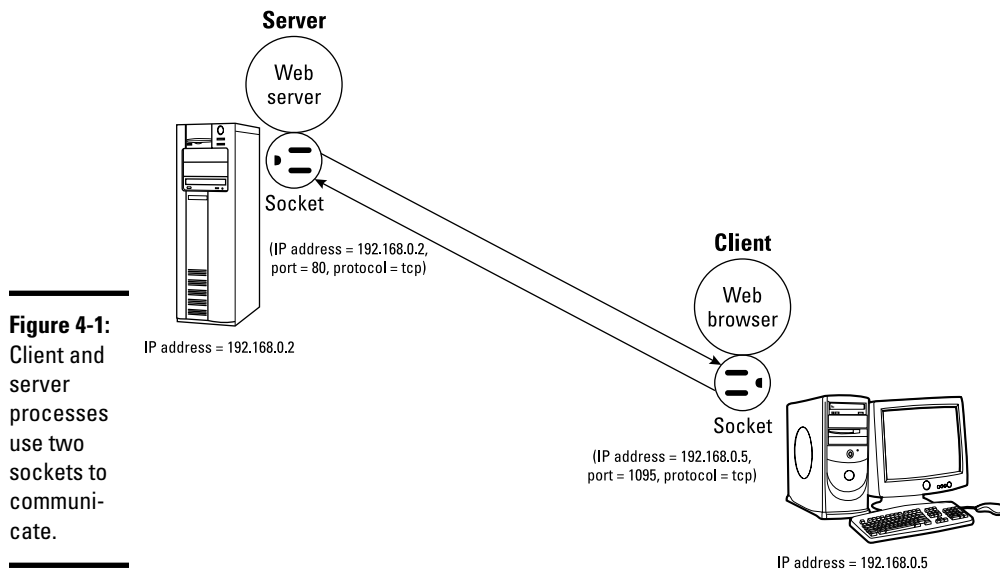

Figure 4-1: Client and server processes use two sockets to communicate.

The sequence of events in socket-based data exchanges depends on whether the transfer is connection-oriented (TCP) or connectionless (UDP).

For a connection-oriented data transfer using sockets, the server listens on a specific port, waiting for clients to request connection. Data transfer begins only after a connection is established.

For connectionless data transfers, the server waits for a datagram to arrive at a specified port. The client does not wait to establish a connection; it simply sends a datagram to the server.

Regardless of whether it's a server or a client, each application first creates a socket. Then it *associates* (binds) the socket with the local computer's IP address and a port number. The IP address identifies the machine (where the application is running), and the port number identifies the application using the socket.



Servers typically listen to a well-known port number so that clients can connect to that port to access the server. For a client application, the process of binding a socket to the IP address and port is the same as that for a server, but the client can use 0 as the port number — the sockets library automatically uses an unused port number for the client.

For a connection-oriented stream socket, the communicating client and server applications have to establish a connection. The exact steps for establishing a connection depend on whether the application is a server or a client.



In the client/server model, the server has to be up and running before the client can run. After creating a socket and binding the socket to a port, the server application sets up a queue of connections, which determines how many clients can connect to the server. Typically, a server listens to anywhere from one to five connections. However, the size of this *listen queue* is one of the parameters you can adjust (especially for a web server) to ensure that the server responds to as many clients as possible. After setting up the listen queue, the server waits for a connection from a client.

Establishing the connection from the client side is somewhat simpler. After creating a socket and binding the socket to an IP address, the client establishes a connection with the server. To make the connection, the client must know the hostname or IP address of the server, as well as the port on which the server accepts connection. All Internet services have well-known standard port numbers.



After a client establishes a connection to a server via a connection-oriented stream socket, the client and server can exchange data by calling the appropriate sockets' API functions. Like a conversation between two persons, the server and client alternately send and receive data — the meaning of the data depends on the message protocol that the server and clients use. Usually, a server is designed for a specific task; inherent in that design is a message protocol that the server and clients use to exchange necessary data. For example, the web server and the web browser (client) communicate using HTTP (HyperText Transfer Protocol).

Internet services and port numbers

The TCP/IP protocol suite is the lingua franca of the Internet because the Internet services *speak* TCP/IP. These services make the Internet tick by making possible the transfer of mail, news, and web pages. Each Internet service has its own protocol that relies on TCP/IP for the actual transfer of the information. Each service also has one or more assigned port numbers that it uses to do whatever it's designed to do. Here are some well-known Internet services and their associated protocols:

- ◆ **DHCP (Dynamic Host Configuration Protocol):** Dynamically configures TCP/IP network parameters on a computer. DHCP is used, primarily, to assign dynamic IP addresses and other networking information such as name server, default gateway, and domain names that are needed to configure TCP/IP networks. The DHCP server listens on port 67.
- ◆ **FTP (File Transfer Protocol):** Transfers files between computers on the Internet. FTP uses two ports: Data is transferred on port 20, and control information is exchanged on port 21.
- ◆ **HTTP (HyperText Transfer Protocol):** Sends documents from one system to another. HTTP is the underlying protocol of the web. By default, the web server and client communicate on port 80.

- ◆ **SMTP (Simple Mail Transfer Protocol):** Exchanges e-mail messages between systems. SMTP uses port 25 for information exchange.
- ◆ **NNTP (Network News Transfer Protocol):** Distributes news articles in a store-and-forward fashion across the Internet. NNTP uses port 119.
- ◆ **SSH (Secure Shell):** Enables secure remote login and other secure network services over an insecure network. SSH uses port 22.
- ◆ **TELNET:** Enables a user on one system to log in to another system on the Internet. (The user must provide a valid user ID and password to log in to the remote system.) TELNET uses port 23 by default, but the TELNET client can connect to any specified port.
- ◆ **NFS (Network File System):** Shares files among computers. NFS uses Sun's Remote Procedure Call (RPC) facility, which exchanges information through port 111.
- ◆ **NTP (Network Time Protocol):** Synchronizes the system time on a client computer with that on a server that has a more accurate clock. NTP uses port 123.
- ◆ **SNMP (Simple Network Management Protocol):** Manages all types of network devices on the Internet. Like FTP, SNMP uses two ports: 161 and 162.
- ◆ **TFTP (Trivial File Transfer Protocol):** Transfers files from one system to another. (It's typically used by X terminals and diskless workstations to download boot files from another host on the network.) TFTP data transfer takes place on port 69.

Each service is provided by a *server process* — a computer program that runs on a system awaiting client requests that arrive at the well-known port associated with its service. Thus the web server expects client requests at port 80, the standard port for HTTP service.

The `/etc/services` text file on your Linux system stores the association between a service name and a port number (as well as a protocol). Here is a small subset of entries in the `/etc/services` file from a Linux system:

```
ftp-data 20/tcp
ftp 21/tcp
fsp 21/udp fspd
ssh 22/tcp # SSH Remote Login Protocol
ssh 22/udp
telnet 23/tcp
smtp 25/tcp mail
time 37/tcp timserver
time 37/udp timserver
rtp 39/udp resource # resource location
nameserver 42/tcp name # IEN 116
whois 43/tcp nickname
tacacs 49/tcp # Login Host Protocol (TACACS)
```

A quick look through the entries in the `/etc/services` file shows the breadth of networking services available under TCP/IP.



Port number 80 is designated for web services. In other words, if you set up a web server on your system, that server listens to port 80. By the way, IANA — the Internet Assigned Numbers Authority (www.iana.org) — is the organization responsible for coordinating the assignment of port numbers below 1,024.

Using the Internet Super Server

The client/server architecture of Internet services requires that the server be up and running before a client makes a request for service. It's probably a bad idea to run all the servers all the time — doing so is impractical because each server process uses up system resources in the form of memory and processor time. Besides, you don't really need *all* the services up and ready at all times. Instead, run a single server that listens to all the ports and then starts the appropriate server when a client request comes in. Such a server is known as the *Internet super server* because it starts various services on demand.



The two Internet super servers are `inetd` and `xinetd`. The `inetd` server is the older one and is still used in some Linux distributions such as Debian, Knoppix, Ubuntu, and Xandros. The `xinetd` server is a replacement for `inetd`, offering improved access control and logging. The name `xinetd` stands for *extended* `inetd`. Distributions such as Fedora and SUSE use `xinetd`.

Using `inetd`

In Linux distributions that use `inetd`, the system starts `inetd` when the system boots. The `inetd` server reads a configuration file named `/etc/inetd.conf` at startup. This file tells `inetd` which ports to listen to and what server to start for each port. For example, the entry in the `/etc/inetd.conf` file that starts the IMAP (Internet Message Access Protocol) on one server looks like this:

```
imapd stream tcp nowait root /usr/sbin/tcpd /usr/sbin/imapd
```

The first item on this line, `imapd`, tells `inetd` the name of the service. `inetd` uses this name to look up the port number from the `/etc/services` file. If you type **grep `imapd` /etc/services**, you find that the port number of the IMAP service is 993. This tells `inetd` to listen to port 993 for FTP service requests.

The rest of the fields on the IMAP entry have the following meanings:

- ◆ The second and third fields of the entry, `stream` and `tcp`, tell `inetd` that the FTP service uses a connection-oriented TCP socket to communicate with the client. For services that use the connectionless UDP sockets, these two fields are `dgram` and `udp`.

- ◆ The fourth field, `nowait`, tells `inetd` to start a new server for each request. If this field is `wait`, `inetd` waits until the server exits before starting the server again.
- ◆ The fifth field provides the user ID that `inetd` uses to run the server. In this case, the server runs the FTP server as `root`.
- ◆ The sixth field specifies the program to run for this service and the last field is the argument that `inetd` passes to the server program. In this case, the `/usr/sbin/tcpd` program is provided `/usr/sbin/imapd` as an argument.



The `/usr/sbin/tcpd` program is an access-control facility, or a *TCP wrapper*, for Internet services. Because unnecessary Internet services are often the sources of security vulnerabilities, you may want to turn off any unneeded services or at least control access to the services. The `tcpd` program can start other services, such as FTP and TELNET, but before starting the service, `tcpd` consults the `/etc/hosts.allow` file to see if the host requesting service is allowed that service. If nothing is in `/etc/hosts.allow` about that host, `tcpd` checks the `/etc/hosts.deny` file to see if the service should be denied. If both files are empty, `tcpd` allows the host access to the requested service. You can place the line `ALL:ALL` in the `/etc/hosts.deny` file to deny all hosts access to any Internet services.



Browse through the `/etc/inetd.conf` file on your system to find out the kinds of services that `inetd` is set up to start. Nowadays, most `inetd` services are turned off, and many others, such as FTP, are started by standalone servers. In any case, if you should see any services that you want to turn off, simply place a hash mark (`#`) at the beginning of the lines that start these services. When you make such a change to the `/etc/inetd.conf` file, type `/etc/init.d/inetd restart` to restart the `inetd` server.

Using *xinetd*

Linux distributions that use `xinetd` start `xinetd` when the system boots. The `xinetd` server reads a configuration file named `/etc/xinetd.conf` at startup. This file tells `xinetd` which ports to listen to and what server to start for each port. The file can contain instructions that include other configuration files. In Linux, the `/etc/xinetd.conf` file looks like the following:

```
# Simple configuration file for xinetd
#
# Set some defaults and include /etc/xinetd.d/
defaults
{
instances = 30
log_type = FILE /var/log/xinetd.log
log_on_success = HOST EXIT DURATION
log_on_failure = HOST ATTEMPT
cps = 50 10
}
includedir /etc/xinetd.d
```

Comment lines begin with the hash mark (#). The defaults block of attributes, enclosed in curly braces ({ . . . }), specifies default values for some attributes. These default values apply to all other services in the configuration file. The `instances` attribute is set to 30, which means that no more than 30 servers can be simultaneously active for any service.



The last line in the `/etc/xinetd.conf` file uses the `includedir` directive to include all files inside the `/etc/xinetd.d` directory, excluding files that begin with a period (.). The idea is that the `/etc/xinetd.d` directory contains all service-configuration files — one file for each type of service the `xinetd` server is expected to manage. Type `ls /etc/xinetd.d` to see the `xinetd` configuration files for your system. Each file in `/etc/xinetd.d` specifies attributes for one service that `xinetd` can start.



For example, SUSE Linux uses `xinetd` to start some services, including the `vsftpd` (Very Secure FTP daemon) server. (A *daemon* is a process that runs continuously and never dies.) Type `cat /etc/xinetd.d/vsftpd` to see the `xinetd` configuration for the `vsftpd` service. Here's a typical listing of that file on a SUSE system:

```
# default: off
# description:
# The vsftpd FTP server serves FTP connections. It uses
# normal, unencrypted usernames and passwords for authentication.
# vsftpd is designed to be secure.
service ftp
{
socket_type = stream
protocol = tcp
wait = no
user = root
server = /usr/sbin/vsftpd
}
```

The filename (in this case, `vsftpd`) can be anything; what matters is the service name that appears next to the service keyword in the file. In this case, the line `service ftp` tells `xinetd` the name of the service. `xinetd` uses this name to look up the port number from the `/etc/services` file.

The attributes in `/etc/xinetd.d/vsftpd`, enclosed in curly braces ({ . . . }), have the following meanings:

- ◆ The `socket_type` attribute is set to `stream`, which tells `xinetd` that the FTP service uses a connection-oriented TCP socket to communicate with the client. For services that use the connectionless UDP sockets, this attribute is set to `dgram`.
- ◆ The `wait` attribute is set to `no`, which tells `xinetd` to start a new server for each request. If this attribute is set to `yes`, `xinetd` waits until the server exits before starting the server again.
- ◆ The `user` attribute provides the user ID that `xinetd` uses to run the server. In this case, the server runs the TELNET server as `root`.

- ◆ The `server` attribute specifies the program to run for this service. In this case, `xinetd` runs the `/usr/sbin/vsftpd` program to provide the FTP service.

Browse through the files in the `/etc/xinetd.d` directory on your Linux system to find out the kinds of services `xinetd` is set up to start. If you want to turn off any service (many are already disabled), you can do so by editing the configuration file for that service and adding the following line inside the curly braces that enclose all attributes:

```
disable = yes
```

When you make such a change to the `xinetd` configuration files, you must restart the `xinetd` server by typing the following command:

```
/etc/init.d/xinetd restart
```



You can typically configure services to run under `xinetd` or as a standalone service. For example, SUSE starts the Very Secure FTP daemon (`vsftpd`) under the control of `xinetd`. Debian and Fedora, however, run `vsftpd` as a standalone server.

Running Standalone Servers

Starting servers through `inetd` or `xinetd` is a smart approach but not always efficient. A web server controlled by `inetd` or `xinetd` would be started often because every time a user clicks a link on a web page, a request arrives for the web service. For such high-demand services, starting the server in a standalone manner is best. In standalone mode, the server can run as a daemon. That means the server listens on the assigned port, and whenever a request arrives, the server handles it by making a copy of itself. In this way, the server keeps running as long as the machine is running — in theory, forever. A more efficient strategy, used for web servers, is to run multiple copies of the server and let each copy handle some of the incoming requests.

You can easily configure your Linux system to start various standalone servers automatically, as shown in this section.

Starting and stopping servers manually

To start a service that's not running, use the `server` command. For example, if the web server (called `httpd` in Fedora) isn't running, you can start it by issuing a special shell script with the following command:

```
/etc/init.d/httpd start
```

That command runs the `/etc/init.d/httpd` script with `start` as the argument. If the `httpd` server is already running and you want to stop it, run the same command with `stop` as the argument, like this:

```
/etc/init.d/httpd stop
```

To stop and start a server again, just use `restart` as the argument:

```
/etc/init.d/httpd restart
```

You can also check the status of any service by using `status` as the argument:

```
/etc/init.d/httpd status
```



In Debian, Ubuntu, and SUSE, where the web server program is called `apache2`, type `/etc/init.d/apache2 start` to start the web server. In Knoppix and Xandros, type `/etc/init.d/apache start`. Use that same command with arguments `stop` or `restart` to stop the web server or restart it.

What are all the services that you can start and stop? Well, the answer is in the files in the `/etc/init.d` directory. To get a look at it, type the following command:

```
ls /etc/init.d
```

All the files you see listed in response to this command are the services installed on your Linux system — and you can start and stop them as needed. You typically find 65 to 70 services listed in the `/etc/init.d` directory.

Starting servers automatically at boot time

You can start, stop, and restart servers manually by using the scripts in the `/etc/init.d` directory, but you want some of the services to start as soon as you boot the Linux system. You can configure servers to start automatically at boot time by using a graphical server-configuration utility or a command.



The command for configuring services to start automatically depends on the distribution. In Debian, Knoppix, Ubuntu, and Xandros, use the `update-rc.d` command. In Fedora and SUSE, use the `chkconfig` command. Both commands are explained in the following sections.

Using the `chkconfig` command in Fedora and SUSE

The `chkconfig` program is a command-line utility in Fedora and SUSE for checking and updating the current setting of servers in Linux. Various combinations of servers are set up to start automatically at different run levels. Each *run level* represents a system configuration in which a selected set of processes runs. You're usually concerned about run levels 3 and 5 because run level 3 is for text mode login and run level 5 is for logging in through a graphical interface.

The `chkconfig` command is simple to use. For example, suppose that you want to automatically start the named server at run levels 3 and 5. All you have to do is log in as `root` and type the following command at the shell prompt:

```
chkconfig --level 35 named on
```

To see the status of the named server, type the following command:

```
chkconfig --list named
```

You see a line of output similar to the following:

```
named 0:off 1:off 2:off 3:on 4:off 5:on 6:off
```

The output shows you the status of the named server at run levels 0 through 6. As you can see, named is set to run at run levels 3 and 5.

If you want to turn off named, you can do so with this command:

```
chkconfig --level 35 named off
```

You can use `chkconfig` to see the status of all services, including the ones started through `xinetd`. For example, you can view the status of all services by typing the following command:

```
chkconfig --list | more
```

The output shows the status of each service for each of the run levels from 0 through 6. For each run level, the service is either on or off. At the very end of the listing, `chkconfig` displays a list of the services that `xinetd` controls. Each `xinetd`-based service is also marked on or off, depending on whether `xinetd` is configured to start the service.

Using the update-rc.d command in Debian, Knoppix, Ubuntu, and Xandros

In Debian, Knoppix, Ubuntu, and Xandros, you can use the `update-rc.d` command to set up services that should start when the system boots at specific boot levels. The easiest way to set up is to use the `defaults` option in a command of this form:

```
update-rc.d service defaults
```

where `service` is the name of the script file in the `/etc/init.d` directory that starts and stops the service, among other things.

When you use the `defaults` option, `update-rc.d` sets up *symbolic links* — shortcuts, in other words — to start the service in run levels 2, 3, 4, and 5 and stop the service in run levels 0, 1, and 6. A sequence number controls the order

in which each service is started. (Services with smaller sequence numbers start before those with larger sequence numbers, and the numbers typically range from 00 through 99.) If you do not specify a sequence number explicitly, `update-rc.d` uses a sequence number of 20 when you use the `defaults` option.

You can also start and stop a service at specific run levels as well as in a specific sequence. For example, to start a service at run levels 2 and 5 at a sequence number of 85 and stop it at run levels 0, 1, and 6 at a sequence of 90, use the following command:

```
update-rc.d service start 85 2 5 . stop 90 0 1 6 .
```

Remember that `service` must be the name of a script file in the `/etc/init.d` directory.



If you need to stop a service from starting at system startup, type **update-rc.d -f service remove** in a terminal window, where `service` is the name of the script file in `/etc/init.d` that starts or stops that service.

Using a GUI service-configuration utility

If you don't like typing commands, you may be able to use a GUI tool to configure the services. Fedora and SUSE include tools such as YaST and the service-configuration utility to manage the services.

The service-configuration utility shows the names of services in a scrolling list. Each line in the list shows the name of a service with a check box in front of the name. A check mark in the box indicates that the service is selected to start at boot time for the current run level. When the dialog box first appears, many services are already selected.

You can scroll up and down the list and click the check box to select or deselect a service. If you click the check box, the check mark alternately turns on and off. Additionally, the utility also shows you whether the selected service is currently running.

After you select all the servers you want to start when the system boots, click the Apply button on the toolbar to save the changes.



By default, the service-configuration utility configures the selected services for the current run level. That means if you're selecting services from the graphical desktop, the system is in run level 5 and the services you configure are set to start at run level 5. If you want to set up the services for a different level, choose that run level from the Edit Runlevel menu.

Table 4-1 shows a list of the services, along with a brief description of each one. The first column shows the name of the service, which is the same as the name of the program that has to run to provide the service. You may

not see all these services listed when you run the GUI service-configuration utility on your system because the exact list of services depends on what is installed on your Linux system.

Table 4-1 **Some Common Services in Linux**

| <i>Service Name</i> | <i>Description</i> |
|---------------------------|--|
| acpid | Listens to Advanced Configuration and Power Interface (ACPI) events from the kernel and notifies other programs when such events occur. ACPI events can occur when the kernel puts the computer into a low-power state (for example, standby mode) to save energy. |
| apache, apache2, or httpd | Runs the Apache World Wide Web (WWW) server. |
| apmd | Monitors the Advanced Power Management (APM) BIOS and logs the status of electric power (AC or battery backup). |
| atd | Runs commands scheduled by the <code>at</code> and <code>cron</code> commands. |
| autofs | Automatically mounts file systems (for example, when you insert a CD-ROM in the CD-ROM drive). |
| cron or crond | Runs user-specified programs according to a periodic schedule set by the <code>crontab</code> command. |
| gpm | Enables the use of the mouse in text mode screens. |
| innd | The InterNetNews daemon — the Internet news server you can use to support local newsgroups on your system. |
| isdn | Starts and stops ISDN (Integrated Services Digital Network) services — a digital communication service over regular phone lines (enable only if you have ISDN service). |
| named | Translates hostnames into IP addresses. <code>named</code> is a server for the Domain Name System (DNS). You can run a copy on your system if you want. |
| network or networking | Enables you to activate or deactivate all network interfaces configured to start at system-boot time. |
| nfs or nfsserver | Enables sharing of file systems specified in the <code>/etc/exports</code> file using the Network File System (NFS) protocol. |

| <i>Service Name</i> | <i>Description</i> |
|----------------------|--|
| nfslock | Provides file-locking capability for file systems exported using the Network File System (NFS) protocol, so other systems (running NFS) can share files from your system. |
| pcmcia | Provides support for PCMCIA devices. |
| portmap | Works with any software that relies on Remote Procedure Calls (RPC). For example, NFS requires the portmap service. |
| samba, smb, or smbfs | Starts and stops the Samba <code>smbd</code> and <code>nmbd</code> services, which support LAN Manager services on a Linux system. |
| sendmail | Moves mail messages from one machine to another. Start this service if you want to send mail from your Linux system. If you don't plan to use your Linux system as a mail server, don't start the <code>sendmail</code> server because it can slow down the booting process and consume resources unnecessarily. |
| snmpd | Manages networks. <code>snmpd</code> stands for Simple Network Management Protocol daemon. |
| spamassassin | Runs <code>spamd</code> — the SpamAssassin mail filter program. |
| ssh or sshd | Runs the OpenSSH (Secure Shell) secure remote login facility. |
| syslog or syslogd | Logs various error and status messages in a log file (usually, the <code>/var/log/messages</code> file). This service is used by many other programs (including other services). Always run this service. |
| vsftpd | Transfers files using the File Transfer Protocol (FTP). <code>vsftpd</code> stands for Very Secure FTP daemon. |
| winbind | Starts and stops the Samba <code>winbindd</code> server, which provides a name-switch capability similar to that provided by the <code>/etc/nsswitch.conf</code> file. |
| xf86 | Starts and stops the X font server. |
| xinetd | Starts other Internet services, such as TELNET and FTP, whenever they are needed. This server is the Internet super server, a replacement for the older <code>inetd</code> . |
| ypbind | Runs on Network Information System (NIS) clients and binds the clients to an NIS domain. You don't have to start <code>ypbind</code> unless you're using NIS. |

Chapter 5: Managing Mail and News Servers

In This Chapter

- ✓ Installing and using `sendmail`
- ✓ Testing mail delivery manually
- ✓ Configuring `sendmail`
- ✓ Installing the InterNetNews (INN) server
- ✓ Configuring and starting INN
- ✓ Setting up local newsgroups

Electronic mail (e-mail) is one of the popular services available on Internet hosts. E-mail software comes in two parts: a *mail transport agent (MTA)*, which physically sends and receives mail messages, and a *mail user agent (MUA)*, which reads messages and prepares new messages. This chapter describes the e-mail service and shows you how to configure the `sendmail` server on a Linux PC.

Internet newsgroups provide another convenient way, besides e-mail, to discuss various topics and share your knowledge with others. Linux comes with the software you need to read newsgroups and set up your own system as a news server. This chapter also describes how to configure and run the popular InterNetNews server and shows how to set up local newsgroups for your corporate intranet (or even your home network).

Installing the Mail Server

Depending on the choices you made during Linux installation, you may have already installed the mail server software on your system. You can choose from several mail servers, such as `exim`, `postfix`, and `sendmail` — `sendmail` is briefly covered in this chapter. If `sendmail` is not installed, you can easily install it.

Using sendmail

To set up your system as a mail server, you must configure the `sendmail` mail transport agent properly. `sendmail` has the reputation of being a complex but complete mail-delivery system. Just one look at `sendmail`'s configuration file — `/etc/mail/sendmail.cf` in Fedora or `/etc/sendmail.cf`

in SUSE — can convince you that `sendmail` is indeed complex. Luckily, you don't have to be an expert on the `sendmail` configuration file. All you need is one of the predefined configuration files — such as the one installed on your system — to use `sendmail`.

Your system already has a working `sendmail` configuration file — `/etc/mail/sendmail.cf`. The default file assumes you have an Internet connection and a name server. Provided that you have an Internet connection and that your system has an official domain name, you can send and receive e-mail from your Linux PC.



To ensure that mail delivery works correctly, your system's name must match the system name that your ISP has assigned to you. Although you can give your system any hostname you want, other systems can successfully deliver mail to your system only if your system's name is in the ISP's name server.

A mail-delivery test

To try the `sendmail` mail transfer agent, you can use the `mail` command to compose and send a mail message to any user account on your Linux system. As a test, compose a message and send it to yourself. For example, here's how to send a message using the `mail` command. (Input appears in boldface.)

```
mail edulaney
Subject: Testing e-mail
This is from my Linux system.
.
```

The `mail` command is a simple mail user agent. In the preceding example, the addressee (`edulaney`) is specified in the command line. The `mail` program prompts for a subject line. Following the subject, enter the message and end it with a line that contains only a period. You will be prompted for a `Cc:`, but leave that blank. After ending the message, the mail user agent passes the message to `sendmail` (the mail transport agent) for delivery to the specified address. `sendmail` delivers the mail message immediately. To verify the delivery of mail, type **mail** to run the `mail` command again and read the message.

If any of your mail server software is not properly installed, you should be prompted during this test to install any needed components and resolve the problem.

Thus the initial `sendmail` configuration file is adequate for sending and receiving e-mail, at least within your Linux system. External mail delivery also works, provided that your Linux system has an Internet connection and a registered domain name.



If you have an ISP account that provides your Linux system with a dynamic IP address, you have to use a mail client such as Evolution or Mozilla Mail, which contacts your ISP's mail server to deliver outbound e-mail.

The mail-delivery mechanism

On an Internet host, the `sendmail` mail transport agent delivers mail using the Simple Mail Transfer Protocol (SMTP). SMTP-based mail transport agents listen to TCP port 25 and use a small set of text commands to exchange information with other mail transport agents. SMTP commands are simple enough that you can use them manually from a terminal to send a mail message. The `telnet` command opens a TELNET session to port 25 (the port on which `sendmail` expects SMTP commands). The `sendmail` process on the Linux system immediately replies with an announcement.

You can type **HELP** to view a list of SMTP commands. To get help on a specific command, type **HELP *commandname***. Type **HELO localhost** to initiate a session with the host. The `sendmail` process replies with a greeting. To send the mail message, start with the `MAIL FROM:` command, which specifies the sender of the message. Next, use the `RCPT TO:` command to specify the recipient of the message. If you want to send the message to several recipients, provide each recipient's address with the `RCPT TO:` command.

To enter the mail message, use the `DATA` command. In response to the `DATA` command, `sendmail` displays an instruction that you have to end the message with a period on a line by itself. After you do so and end the message, the `sendmail` process displays a message indicating that the message is accepted for delivery. You can then quit the `sendmail` session with the `QUIT` command.

The sendmail configuration file

You don't have to understand everything in the `sendmail` configuration file, `sendmail.cf`, but you need to know how that file is created. That way, you can make minor changes if necessary and regenerate the `sendmail.cf` file.



In SUSE, you can configure `sendmail` through the YaST Control Center — choose System → Control Center (YaST) from the main menu. Click Network Services in the left side of the window, and then click Mail Transfer Agent in the right side of the window. YaST displays a window that you can use to configure `sendmail`. First you specify the general settings, then the settings for outgoing mail, and finally the settings for incoming mail. After you exit the mail configuration utility, YaST stores the mail settings in the files `/etc/sysconfig/sendmail` and `/etc/sysconfig/mail` and then runs `SuSEconfig` to update the `sendmail` configuration file (`/etc/sendmail.cf`).

You can also generate the `sendmail.cf` file from a number of *m4 macro files* (text files in which each line eventually expands to multiple lines that mean something to some program). These macro files are organized into a number of subdirectories in the `/usr/share/sendmail-cf` directory in Fedora or the `/usr/share/sendmail` directory in SUSE. You can read the `README` file in that directory to find out more about the creation of `sendmail` configuration files.

The m4 macro processor

The m4 macro processor generates the `sendmail.cf` configuration file, which comes with the `sendmail` package in Linux. The main macro file, named `sendmail.mc`, `generic_linux.mc`, or `linux.mc`, is included with the `sendmail` package.



So what's a macro? A *macro* is basically a symbolic name for code that handles some action, usually in a shorthand form that substitutes for a long string of characters. A *macro processor* such as m4 usually reads its input file and copies it to the output, processing the macros along the way. The processing of a macro generally involves performing some action and generating some output. Because a macro generates a lot more text in the output than merely the macro's name, the processing of macros is referred to as *macro expansion*.

The m4 macro processor is *stream-based*. That means it copies the input characters to the output while it's busy expanding any macros. The m4 macro processor does not have any concept of lines, so it copies newline characters (that mark the end of a line) to the output. That's why in most m4 macro files you see `dn1`, an m4 macro that stands for *delete through newline*. The `dn1` macro deletes all characters starting at the `dn1` up to and including the next newline character. The newline characters in the output don't cause any harm; they merely create unnecessary blank lines. The `sendmail` macro package uses `dn1` to avoid such blank lines in the output configuration file. Because `dn1` basically means delete everything up to the end of the line, m4 macro files also use `dn1` as the prefix for comment lines.

To see a simple use of m4, consider the following m4 macro file, which defines two macros — `hello` and `bye` — and uses them in a form letter:

```
dn1 #####
dn1 # File: ex.m4
dn1 # A simple example of m4 macros
dn1 #####
define('hello', 'Dear Sir/Madam')dn1
define('bye',
'Sincerely,
Customer Service')dn1
dn1 Now type the letter and use the macros
hello,
This is to inform you that we received your recent inquiry.
We will respond to your question soon.
bye
```

Type this text (using your favorite text editor) and save it in a file named `ex.m4`. You can name a macro file anything you like, but using the `.m4` extension for m4 macro files is customary.

Before you process the macro file by using m4, note the following key points about the example:

- ◆ Use the `dn1` macro to start all the comment lines, as in the first four lines in the example.

- ◆ End each macro definition with the `dn1` macro. Otherwise, when `m4` processes the macro file, it produces a blank line for each macro definition.
- ◆ Use the built-in `m4` command `define` to define a new macro. The macro name and the value are both enclosed between a pair of left and right single quotes (' . . . '). Note that you cannot use the plain single quote to enclose the macro name and definition.

Now process the macro file `ex.m4` by typing the following command:

```
m4 ex.m4
```

`m4` processes the macros and displays the following output:

```
Dear Sir/Madam,
This is to inform you that we received your recent inquiry.
We will respond to your question soon.
Sincerely,
Customer Service
```

Sounds just like a typical customer service form letter, doesn't it?

If you compare the output with the `ex.m4` file, you see that `m4` prints the form letter on standard output, expanding the macros `hello` and `bye` into their defined values. If you want to save the form letter in a file called `letter`, use the shell's output redirection feature, like this:

```
m4 ex.m4 > letter
```

What if you want to use the word *hello* or *bye* in the letter without expanding them? You can do so by enclosing these words in a pair of single quotes (' . . . '). You have to do so for other predefined `m4` macros, such as `define`. To use *define* as a plain word, not as a macro to expand, type **'define'**.

The sendmail macro file

The simple example in the preceding section gives you an idea of how `m4` macros are defined and used to create configuration files such as the `sendmail.cf` file. You find many complex macros stored in files in the `/usr/share/sendmail-cf` directory in Fedora or the `/usr/share/sendmail` directory in SUSE. A top-level macro file (called `sendmail.mc` in Fedora and `linux.mc` in SUSE), described later in this section, brings in these macro files with the `include` macro (used to copy a file into the input stream).

To avoid repeatedly mentioning different file and directory names for different distributions such as Fedora and SUSE, I use the file and directory names for Fedora in the following discussions. The general discussions apply to `sendmail` in all Linux distributions, but you have to replace the file and directory names with those for your specific distribution.

By defining its own set of high-level macros in files located in the `/usr/share/sendmail-cf` directory, `sendmail` essentially creates its own macro language. The `sendmail` macro files use the `.mc` extension. The



primary sendmail macro file you configure is `sendmail.mc`, located in the `/etc/mail` directory.

Compared to the `/etc/mail/sendmail.cf` file, the `/etc/mail/sendmail.mc` file is shorter and easier to work with. Here are some lines from the `/etc/mail/sendmail.mc` file that comes with Fedora:

```
divert(-1)dnl
dnl #
dnl # This is the sendmail macro config file for m4. If you make changes
    to
dnl # /etc/mail/sendmail.mc, you will need to regenerate the
dnl # /etc/mail/sendmail.cf file by confirming that the sendmail-cf
    package is
dnl # installed and then performing a
dnl #
dnl # /etc/mail/make
dnl #
include('/usr/share/sendmail-cf/m4/cf.m4')dnl
VERSIONID('setup for linux')dnl
OSTYPE('linux')dnl
dnl #
dnl # Do not advertise sendmail version.
dnl #
dnl define('confSMTP_LOGIN_MSG', '$j Sendmail; $b')dnl
dnl #
dnl # default logging level is 9, you might want to set it higher to
dnl # debug the configuration
dnl #
dnl define('confLOG_LEVEL', '9')dnl
dnl #
dnl # Uncomment and edit the following line if your outgoing mail needs to
dnl # be sent out through an external mail server:
dnl #
dnl define('SMART_HOST', 'smtp.your.provider')dn
. . . lines deleted . . .
dnl #
dnl MASQUERADE_AS('mydomain.com')dnl
dnl #
dnl # masquerade not just the headers, but the envelope as well
dnl #
dnl FEATURE(masquerade_envelope)dnl
dnl #
dnl # masquerade not just @mydomainalias.com, but @*.mydomainalias.com as well
dnl #
dnl FEATURE(masquerade_entire_domain)dnl
dnl #
dnl MASQUERADE_DOMAIN(localhost)dnl
dnl MASQUERADE_DOMAIN(localhost.localdomain)dnl
dnl MASQUERADE_DOMAIN(mydomainalias.com)dnl
dnl MASQUERADE_DOMAIN(mydomain.lan)dnl
MAILER(smtp)dnl
MAILER(procmail)dnl
dnl MAILER(cyrusv2)dnl
```



If you make changes to the `/etc/mail/sendmail.mc` file, you must generate the `/etc/mail/sendmail.cf` file by running the `sendmail.mc` file through the `m4` macro processor with the following command. (You have to log in as `root`.)

```
m4 /etc/mail/sendmail.mc > /etc/mail/sendmail.cf
```

The comments also tell you that you need the `sendmail-cf` package to process this file.

From the previous section's description of `m4` macros, you can see that the `sendmail.mc` file uses `define` to create new macros. You can also see the liberal use of `dn1` to avoid inserting too many blank lines into the output.

The other uppercase words (such as `OSTYPE`, `FEATURE`, and `MAILER`) are `sendmail` macros. These are defined in the `.m4` files located in the subdirectories of the `/usr/share/sendmail-cf` directory and are incorporated into the `sendmail.mc` file with the following `include` macro:

```
include('usr/share/sendmail-cf/m4/cf.m4') dn1
```

The `/usr/share/sendmail-cf/m4/cf.m4` file, in turn, includes the `cfhead.m4` file, which includes other `m4` files, and so on. The net effect is as follows: As the `m4` macro processor processes the `sendmail.mc` file, the macro processor incorporates many `m4` files from various subdirectories of `/usr/share/sendmail-cf`.

Here are some key points to note about the `/etc/mail/sendmail.mc` file:

- ◆ `VERSIONID('setup for linux')` macro inserts the version information enclosed in quotes into the output.
- ◆ `OSTYPE('linux')` specifies Linux as the operating system. You have to specify this macro early to ensure proper configuration.



Placing this macro right after the `VERSIONID` macro is customary.

- ◆ `MAILER(smtp)` describes the mailer. According to instructions in the `/usr/share/sendmail-cf/README` file, `MAILER` declarations are always placed at the end of the `sendmail.mc` file and `MAILER(smtp)` always precedes `MAILER(procmail)`. The mailer `smtp` refers to the SMTP mailer.
- ◆ `FEATURE` macros request various special features. For example, `FEATURE('blacklist_recipients')` turns on the capability to block incoming mail for certain usernames, hosts, or addresses. The specification for what mail to allow or refuse is placed in the access database (stored in `/etc/mail/access.db` file). You also need the `FEATURE('access_db')` macro to turn on the access database.
- ◆ `MASQUERADE_AS('mydomain.com')` causes `sendmail` to label outgoing mail as having come from the host `mydomain.com` (replace `mydomain` with your domain name). The idea is for a large organization to set up a single `sendmail` server that handles the mail for many subdomains and makes everything appear to come from a single domain. (For example, mail from many departments in a university appears to come from the university's main domain name.)

- ◆ `MASQUERADE_DOMAIN(subdomain.mydomain.com)` instructs `sendmail` to send mail from an address such as `user@subdomain.mydomain.com` as having originated from the same username at the domain specified by the `MASQUERADE_AS` macro.

The `sendmail` macros such as `FEATURE` and `MAILER` are described in the `/usr/share/sendmail-cf/README` file. Consult that file to find out more about the `sendmail` macros before you make changes to the `sendmail.mc` file.

Syntax of the `sendmail.cf` file

The `sendmail.cf` file's syntax is designed to be easy for the `sendmail` program to parse because `sendmail` reads this file whenever it starts. Human readability was not a primary consideration when the file's syntax was designed. Still, with a little explanation, you can understand the meaning of the control lines in `sendmail.cf`.

Each `sendmail` control line begins with a single-letter operator that defines the meaning of the rest of the line. A line that begins with a space or a tab is considered a continuation of the previous line. Blank lines and lines beginning with a pound sign (`#`) are comments.

Often, no space appears between the single-letter operator and the arguments that follow the operator, which makes the lines even harder to understand. For example, `sendmail.cf` uses the concept of a *class* — essentially a collection of phrases. You can define a class named `P` and add the phrase `REDIRECT` to that class with the following control line:

```
CPREDIRECT
```

Because everything runs together, the command is hard to decipher. On the other hand, to define a class named `Accept` and set it to the values `OK` and `RELAY`, write the following:

```
C{Accept}OK RELAY
```

This command may be slightly easier to understand because the delimiters (such as the class name, `Accept`) are enclosed in curly braces.

Other, more recent control lines are even easier to understand. For example, the line

```
O HelpFile=/etc/mail/helpfile
```

defines the option `HelpFile` as the filename `/etc/mail/helpfile`. That file contains help information that `sendmail` uses when it receives a `HELP` command.

Table 5-1 summarizes the one-letter control operators used in `sendmail.cf`. Each entry also shows an example of that operator. This table helps you understand some of the lines in `sendmail.cf`.

| Table 5-1 Control Operators Used in <code>sendmail.cf</code> | |
|---|---|
| Operator | Description |
| C | Defines a class, a variable (think of it as a set) that can contain several values. For example, <code>Cwlocalhost</code> adds the name <code>localhost</code> to the class <code>w</code> . |
| D | Defines a macro, a name associated with a single value. For example, <code>DnMAILER-DAEMON</code> defines the macro <code>n</code> as <code>MAILER-DAEMON</code> . |
| F | Defines a class that's been read from a file. For example, <code>Fw/etc/mail/local-host-names</code> reads the names of hosts from the file <code>/etc/mail/local-host-names</code> and adds them to the class <code>w</code> . |
| H | Defines the format of header lines that <code>sendmail</code> inserts into a message. For example, <code>H?P?Return-Path: <\$g></code> defines the <code>Return-Path:</code> field of the header. |
| K | Defines a map (a key-value pair database). For example, <code>Karith arith</code> defines the map named <code>arith</code> as the compiled-in map of the same name. |
| M | Specifies a mailer. The following lines define the <code>procmail</code> mailer: <code>Mprocmail, P=/usr/bin/procmail, F=DFMSPH nu9, S=EnvFromSMTP/HdrFromSMTP, R=EnvToSMTP/HdrFromSMTP, T=DNS/RFC822/X-Unix, A=procmail -Y -m \$h \$f \$u</code> . |
| O | Assigns a value to an option. For example, <code>O AliasFile=/etc/aliases</code> defines the <code>AliasFile</code> option to <code>/etc/aliases</code> , which is the name of the <code>sendmail</code> alias file. |
| P | Defines values for the precedence field. For example, <code>Pjunk=-100</code> sets to <code>-100</code> the precedence of messages marked with the header field <code>Precedence: junk</code> . |
| R | Defines a rule. (A rule has a left side and a right side; if input matches the left side, the right side replaces it. This rule is called <i>rewriting</i> .) For example, the rewriting rule <code>R\$* ; \$1</code> strips trailing semicolons. |
| S | Labels a ruleset you can start defining with subsequent <code>R</code> control lines. For example, <code>Sanonify=3</code> labels the next ruleset as <code>canonify</code> and ruleset <code>3</code> . |
| T | Adds a username to the trusted class (class <code>t</code>). For example, <code>Troot</code> adds <code>root</code> to the class of trusted users. |
| V | Defines the major version number of the configuration file. |

Other sendmail files

The `/etc/mail` directory contains other files that `sendmail` uses. These files are referenced in the `sendmail` configuration file, `/etc/mail/sendmail.cf` in Fedora and `/etc/sendmail.cf` in SUSE. For example, here's how you can search for the `/etc/mail` string in the `/etc/mail/sendmail.cf` file in Fedora:

```
grep "\/etc\/mail" /etc/mail/sendmail.cf
```

Here's what the `grep` command displays as a result of the search on a typical Fedora system:

```
Fw/etc/mail/local-host-names
FR-o /etc/mail/relay-domains
Kmailertable hash -o /etc/mail/mailertable.db
Kvirtuser hash -o /etc/mail/virtusertable.db
Kaccess hash -T<TMPF> -o /etc/mail/access.db
#O ErrorHandler=/etc/mail/error-header
O HelpFile=/etc/mail/helpfile
O UserDatabaseSpec=/etc/mail/userdb.db
#O ServiceSwitchFile=/etc/mail/service.switch
#O DefaultAuthInfo=/etc/mail/default-auth-info
Ft/etc/mail/trusted-users
```

You can ignore the lines that begin with a hash mark, or number sign (`#`) because `sendmail` treats those lines as comments. The other lines are `sendmail` control lines that refer to other files in the `/etc/mail` directory.

Here's what some of these `sendmail` files are supposed to contain. (Note that not all of these files have to be present in your `/etc/mail` directory, and even when present, some files may be empty.)

- ◆ `/etc/mail/access`: Names or IP addresses or both of hosts allowed to send mail (useful in stopping *spam* — unwanted e-mail).
- ◆ `/etc/mail/access.db`: Access database generated from the `/etc/mail/access` file.
- ◆ `/etc/mail/helpfile`: Help information for SMTP commands.
- ◆ `/etc/mail/local-host-names`: Names by which this host is known.
- ◆ `/etc/mail/mailertable`: Mailer table used to override how mail is routed. (For example, the entry `comcast.net smtp:smtp.comcast.net` tells `sendmail` that mail addressed to `comcast.net` has to be sent to `smtp.comcast.net`.)
- ◆ `/etc/mail/relay-domains`: Hosts that permit relaying.
- ◆ `/etc/mail/trusted-users`: List of users allowed to send mail using other users' names without a warning.

- ◆ `/etc/mail/userdb.db`: User database file containing information about each user's login name and real name.
- ◆ `/etc/mail/virtusertable`: Database of users with virtual-domain addresses hosted on this system.



The `/etc/mail` directory sometimes contains other files — `/etc/mail/certs` and the files with the `.pem` extension — that are meant for supporting Privacy Enhanced Mail (PEM) in `sendmail` by using the STARTTLS extension to SMTP. The STARTTLS extension uses TLS (more commonly known as SSL — Secure Sockets Layer) to authenticate the sender and encrypt mail. RFC 2487 describes STARTTLS. (This RFC is available online at <http://ietf.org/rfc/rfc2487.txt>.)



If you edit the `/etc/mail/mailertable` file, you have to type the following command before the changes take effect:

```
makemap hash /etc/mail/mailertable < /etc/mail/mailertable
```

Here is an easier way to make sure that you rebuild everything necessary after making any changes — just type the following commands while logged in as `root`:

```
cd /etc/mail
make
```

The first command changes the current directory to `/etc/mail`, and the second command runs the `make` command, which reads a file named `Makefile` in `/etc/mail` to perform the steps necessary to rebuild everything. (To find out more about `make` and `Makefile`, see Book VII, Chapter 3.)

The `.forward` file

Users can redirect their own mail by placing a `.forward` file in their home directory. The `.forward` file is a plain-text file with a comma-separated list of mail addresses. Any mail sent to the user is instead forwarded to these addresses. If the `.forward` file contains a single address, all e-mail for that user is redirected to that single e-mail address. For example, suppose a `.forward` file containing the following line is placed in the home directory of a user named `emily`:

```
ashley
```

This line causes `sendmail` to automatically send all e-mail addressed to `emily` to the username `ashley` on the same system. User `emily` does not receive mail at all.

You can also forward mail to a username on another system by listing a complete e-mail address. For example, you can add a `.forward` file with the following line to send messages addressed to username `wilbur` to the mail address `wilbur@somewhereelse.net`:

```
wilbur@somewhereelse.net
```

To keep a copy of the message on the original system, in addition to forwarding to the preceding specified address, add the following line to the `.forward` file:

```
wilbur@somewhereelse.net, wilbur\
```

Simply append the username and end the line with a backslash (`\`). The backslash at the end of the line stops `sendmail` from repeatedly forwarding the message.

The sendmail alias file

In addition to the `sendmail.cf` file, `sendmail` also consults an alias file named `/etc/aliases` to convert a name into an address. The location of the alias file appears in the `sendmail` configuration file.

Each *alias* is typically a shorter name for an e-mail address. The system administrator uses the `sendmail` alias file to forward mail, to create a mailing list (a single alias that identifies several users), or to refer to a user by several different names. For example, here are some typical aliases:

```
brown: glbrown
all: jessica, isaac, alex, caleb, glbrown
```



After defining any new aliases in the `/etc/aliases` file, you must log in as `root` and make the new alias active by typing the following command:

```
sendmail -bi
```

Installing the INN Server

This section describes how to configure InterNetNews (INN), a TCP/IP-based news server. First you have to install INN.



In Debian, Ubuntu, and Xandros, type **`dpkg -l inn*`** to see whether `inn` is installed. In Fedora and SUSE, type **`rpm -q inn`** and see whether the `inn` package is installed.



In Debian and Ubuntu, type **`apt-get install inn`** to install the INN server. In Fedora, log in as `root`, mount the DVD, and type **`cd /media/cdrom/Fedora/RPMS`** followed by **`rpm -ivh inn*`**. In SUSE, click Software Management in the YaST Control Center's Software category. Then use YaST's search feature to look for `inn`, select the relevant packages from the search results, and install

them. In Xandros, first run Xandros Networks, choose Edit⇒Set Application Sources, and click the `Debian Unsupported Site` link as a source. Then type **apt-get install inn** to install the INN server.

Configuring and Starting the INN Server

Much of the INN (InterNetNews) software is ready to go as soon as you install it. All you need to do is to brush up a bit on the various components of INN, edit the configuration files, and start `innd` — the INN server. The INN server is sometimes referred to as the *news server*.

If you want to run a news server that supports a selection of Internet newsgroups, you also have to arrange for a *news feed* — the source from which your news server gets the newsgroup articles. Typically, you can get a news feed from an ISP, but the ISP charges an additional monthly fee to cover the cost of resources required to provide the feed. (Your normal ISP charges cover reading news from the ISP's server; you have to pay additional charges only if you want to run your own server and get a news feed.) You need the name of the upstream server that provides the news feed, and you have to provide that server with your server's name and the newsgroups you want to receive.

By the way, you don't need an external news feed if you're running a news server to support local newsgroups that are available only within your organization's network. How to set up local newsgroups is described in the "Setting Up Local Newsgroups" section of this chapter.

Depending on the newsgroups you want to receive and the number of days you want to retain articles, you have to set aside appropriate disk space to hold the articles. The newsgroups are stored in a directory hierarchy (based on the newsgroup names) in the `/var/spool/news` directory of your system. If you're setting up a news server, you may want to devote a large disk partition to the `/var/spool/news` directory.

In your news server's configuration files, enter the name of the server providing the news feed. At the same time, add to the configuration files the names of any downstream news servers (if any) that receive news feeds from your server. Then you can start the news server and wait for news to arrive. Monitor the log files to ensure that the news articles sort and store properly in the `/var/spool/news` directory on your system.

The following sections introduce you to INN setup, but you can find out more about INN from the Internet Systems Consortium (ISC), a nonprofit corporation dedicated to developing and maintaining open source Internet software, such as BIND (an implementation of Domain Name System), DHCP (Dynamic Host Configuration Protocol), and INN. Rich Salz originally wrote INN; ISC took over the development of INN in 1996. You can find out more about INN and can access other resources at ISC's INN web page at `.www.isc.org/downloads` (click on the `Other Software` link).

InterNetNews components

INN includes several programs that deliver and manage newsgroups. It also includes a number of files that control how the INN programs work. The most important INN programs are the following:

- ◆ `innd`: Accepts connections from other feed sites, as well as from local newsreader clients, but it hands off local connections to the `nnrpd`. The news server `innd` runs as a *daemon* (a background process that keeps itself running to provide a specific service) and listens on the NNTP port (TCP port 119).
- ◆ `nnrpd`: Handles requests from local newsreader clients. `nnrpd` is a special server invoked by `innd`.
- ◆ `expire`: Removes old articles based on the specifications in the text file `/etc/news/expire.ctl`.
- ◆ `nntpsend`: Invokes the `innxmit` program to send news articles to a remote site by using NNTP. The configuration file `/etc/news/nntpsend.ctl` controls the `nntpsend` program.
- ◆ `ctlinnd`: Enables you to control the `innd` server interactively. The `ctlinnd` program can send messages to the control channel of the `innd` server.

The other vital components of INN are the control files. Most of these files are in the `/etc/news` directory of your Linux system, although a few are in the `/var/lib/news` directory. Between those two directories, you have more than 30 INN control files. Some important files include the following:

- ◆ `/etc/news/inn.conf`: Specifies configuration data for the `innd` server. (To view online help for this file, type **man inn.conf**.)
- ◆ `/etc/news/newsfeeds`: Specifies what articles to feed downstream to other news servers. (The file is complicated, but you can get help by typing **man newsfeeds**.)
- ◆ `/etc/news/incoming.conf`: Lists the names and addresses of hosts that provide news feeds to this server. (To view online help for this file, type **man incoming.conf**.)
- ◆ `/etc/news/storage.conf`: Specifies the storage methods to be used when storing news articles. (To view online help for this file, type **man storage.conf**.)
- ◆ `/etc/news/expire.ctl`: Controls expiration of articles, on a per-newsgroup level, if desired. (To view online help for this file, type **man expire.ctl**.)
- ◆ `/var/lib/news/active`: Lists all active newsgroups, showing the oldest and newest article number for each, and each newsgroup's posting status. (To view online help for this file, type **man active**.)

- ◆ `/var/lib/news/newsgroups`: Lists newsgroups and a brief description of each.
- ◆ `/etc/news/readers.conf`: Specifies hosts and users who are permitted to read news from this news server and post news to newsgroups. The default file allows only the localhost to read news; you have to edit it if you want to allow other hosts in your local area network to read news. (To view online help for this file, type **man readers.conf**.)

The next few sections describe how to set up some of the important control files.

The inn.conf file

The `inn.conf` file holds configuration data for all INN programs — which makes it the most important file. Each line of the file has the value of a parameter in the following format:

parameter: value

Depending on the *parameter*, the *value* is a string, a number, or true or false. As in many other configuration files, comment lines begin with a pound sign (#).

Most of the parameters in the default `inn.conf` file in the `/etc/news` directory do not require changes. You may want to edit one or more of the parameters shown in Table 5-2.

Table 5-2 Configuration Parameters in `/etc/news/inn.conf`

| <i>Parameter Name</i> | <i>Set This To</i> |
|---------------------------|---|
| <code>mta</code> | The command used to start the mail transfer agent that is used by <code>inn</code> to transfer messages. The default is to use <code>sendmail</code> . |
| <code>organization</code> | The name of your organization in the way you want it to appear in the <code>Organization:</code> header of all news articles posted from your system. Users may override this parameter by defining the <code>ORGANIZATION</code> environment variable. |
| <code>ovmethod</code> | The type of overview storage method. (The <i>overview</i> is an index of news articles in the newsgroup.) The default method is <code>tradindexed</code> , which is fast for reading news but slow for storing news items. |
| <code>pathhost</code> | The name of your news server as you want it to appear in the <code>Path</code> header of all postings that go through your server. If <code>pathhost</code> isn't defined, the fully qualified domain name of your system is used. |

(continued)

Table 5-2 (continued)

| <i>Parameter Name</i> | <i>Set This To</i> |
|-----------------------|---|
| pathnews | The full pathname of the directory that contains INN binaries and libraries. The default pathnews is set to /usr/lib/news. |
| domain | The domain name for your server. |
| allownewnews | True if you want INN to support the NEWNEWS command from newsreaders. In the past, this option was set to false because the NEWNEWS command used to reduce the server's performance, but now the default is set to true because modern servers can easily handle the NEWNEWS command. |
| hiscachesize | The size in kilobytes that you want INN to use for caching recently received message IDs that are kept in memory to speed history lookups. This cache is used only for incoming feeds, and a small cache can hold quite a few history file entries. The default setting of 0 disables history caching. If you have more than one incoming feed, you may want to set this parameter to a value of 256 (for 256KB). |
| innflags | Any flags you want to pass to the INN server process when it starts. |

The newsfeeds file

The newsfeeds file (found at /etc/news/newsfeeds) specifies how incoming news articles are redistributed to other servers and to INN processes. If you provide news feeds to other servers, you have to list these news feeds in this file. (You also must have an entry labeled ME, which serves a special purpose explained later in this section.)

The newsfeeds file contains a series of entries, one for each feed. Each feed entry has the following format:

```
site[/exclude,exclude . . . ]\  
:pattern,pattern . . . [/distrib,distrib . . . ]\  
:flag,flag . . .\  
:param
```

Each entry has four fields separated by a colon (:). Usually the entries span multiple lines, and a backslash (\) at the end of the line continues a line to the next. Here's what the four fields mean:

- ◆ The first field, *site*, is the name of the feed. Each name must be unique, and for feeds to other news servers, the name is set to the hostname of the remote server. Following the name is an optional slash and an exclude list (/exclude,exclude . . .) of names. If any of the

names in this list appear in the `Path` line of an article, that article isn't forwarded to the feed. You can use an `exclude` list if you don't want to receive articles from a specific source.

- ◆ The second field is a comma-separated list of newsgroup *patterns*, such as `*,@alt.binaries.warez.*,!control*,!local*`, followed by an optional *distribution* list. The distribution list is a list of comma-separated keywords, with each keyword specifying a specific set of sites to which the articles are distributed. The newsgroup patterns essentially define a subscription list of sites that receive this news feed. An asterisk (*) matches all newsgroups. A pattern beginning with @ causes newsgroups matching that pattern to be dropped. A pattern that begins with an exclamation mark (!) means the matching newsgroups are not sent. The simple pattern-matching syntax used in INN configuration files is referred to as a *wildmat* pattern.
- ◆ The third field is a comma-separated list of *flags* — fields that determine the feed-entry type and set certain parameters for the entry. You see numerous flags; type **man newsfeeds** and read the man page for more information about the flags.
- ◆ The fourth field is for parameters whose values depend on the settings in the third field. Typically this field contains names of files or external programs that the INN server uses. You can find more about this field from the `newsfeeds` man page.

Now that you know the layout of the `/etc/news/newsfeeds` file, you can study that file as an example. The default file contains many sample feed entries, but only two are commented out:

- ◆ `ME` is a special feed entry that's always required. It serves two purposes. First, the newsgroup patterns listed in this entry are used as a prefix for all newsgroup patterns in all other entries. Second, the `ME` entry's distribution list determines what distributions your server accepts from remote sites.
- ◆ The `controlchan` feed entry is used to set up INN so that an external program is used to handle control messages. (These messages are used to create new newsgroups and remove groups.) For example, the following `controlchan` entry specifies the external program `/usr/lib/news/bin/controlchan` to handle all control messages, except cancel messages (meant for canceling an article):

```
controlchan!\
:!* ,control ,control.* ,!control.cancel\
:Tc,Wnsm:/usr/lib/news/bin/controlchan
```

In addition to these feed entries, you add entries for any actual sites to which your news server provides news feeds. Such entries have the format

```
feedme.domain.com\
: !junk,!control/!foo\
:Tm:innfeed!
```

where `feedme.domain.com` is the fully qualified domain name of the site to which your system sends news articles.

The incoming.conf file

The `incoming.conf` file describes which hosts are allowed to connect to your host to feed articles. For a single feed, you can add an entry like

```
peer mybuddy {
hostname: a-feed-site.domain.com
}
```

where `mybuddy` is a label for the peer and `a-feed-site.domain.com` identifies the site that feeds your site.



Keep in mind that simply adding a site's name in the `incoming.conf` file does not cause that remote site to start feeding news to your site; it simply enables your server to accept news articles from the remote site. At the remote site, your buddy has to configure his or her server to send articles to your site.

The readers.conf file

The `readers.conf` file specifies the hostnames or IP addresses from which newsreader clients (such as Mozilla) can retrieve newsgroups from your server. For example, the following `readers.conf` file allows *read access* and *post access* (meaning you can submit articles) from `localhost` and from any host in the network `192.168.0.0`:

```
auth "localhost" {
hosts: "localhost, 127.0.0.1, stdin"
default: "<localhost>"
}
access "localhost" {
users: "<localhost>"
newsgroups: "*"
access: RPA
}
auth "localnet" {
hosts: 192.168.0.0/24
default: "<localnet>"
}
access "localnet" {
users: "<localnet>"
newsgroups: "*"
access: RPA
}
```

InterNetNews startup

In addition to the configuration files, you also have to initiate `cron` jobs that perform periodic maintenance of the news server. In Fedora, these

cron jobs are already set up. Therefore, you're now ready to start the INN server — `innd`.

Before you start `innd`, you must run `makehistory` and `makedbz` to initialize and rebuild the INN history database. Type **man makehistory** and **man makedbz** to find out more about these commands. To create an initial history database, associated indexes, and set the ownerships and permissions of some files, type the following commands:

```
/usr/lib/news/bin/makehistory -b -f history -O -l 30000 -I
cd /var/lib/news
/usr/lib/news/bin/makedbz -s 'wc -l < history' -f history
chown news.news *
chown news.news /var/spool/news/overview/group.index
chmod 664 /var/spool/news/overview/group.index
```



To start `innd` in Fedora, log in as `root` and type `/etc/init.d/innd start`. (Alternatively, you can type **service innd start**.) In Debian, SUSE, Ubuntu, and Xandros, type `/etc/init.d/innd start`. To ensure that `innd` starts at boot time, type **chkconfig --level 35 innd on** in Fedora and **chkconfig --level 35 inn on** in SUSE. In Debian and Xandros, type **update-rc.d inn defaults**.



If you make any changes to the INN configuration files, remember to restart the server by invoking the `/etc/init.d` script with `restart` as the argument.

Setting Up Local Newsgroups

If you want to use newsgroups as a way to share information within your company, you can set up a hierarchy of local newsgroups. Then you can use these newsgroups to create virtual communities within your company, where people with shared interests can informally discuss issues and exchange knowledge.

Defining a newsgroup hierarchy

The first task is to define a hierarchy of newsgroups, deciding what each newsgroup discusses. For example, if your company name is XYZ Corporation, here's a partial hierarchy of newsgroups you might define:

- ◆ `xyz.general`: General items about XYZ Corporation
- ◆ `xyz.weekly.news`: Weekly news
- ◆ `xyz.weekly.menu`: The weekly cafeteria menu and any discussions about it
- ◆ `xyz.forsale`: A listing of items offered for sale by employees
- ◆ `xyz.jobs`: Job openings at XYZ Corporation
- ◆ `xyz.wanted`: Wanted (help, items to buy, and so on) postings by employees

- ◆ `xyz.technical.hardware`: Technical discussions about hardware
- ◆ `xyz.technical.software`: Technical discussions about software

Updating configuration files

Following are the steps you follow to update the configuration files for your local newsgroups and restart the news server:

1. Add descriptive entries for each newsgroup to the `/var/lib/news/newsgroups` file.

Add to this file a line for each local newsgroup — type its name followed by a brief description. For example, here's what you might add for the `xyz.general` newsgroup:

```
xyz.general General items about XYZ Corporation
```

2. Edit the `ME` entry in the `/etc/news/newsfeeds` file and add the phrase `,!xyz.*` to the comma-separated list of newsgroup patterns.

This step ensures that your local newsgroups are not distributed outside your site.

3. Add a storage method to use for the local newsgroups.

For example, you can add the following lines in `/etc/news/storage.conf` to define the storage method for the new `xyz` hierarchy of newsgroups (change `xyz` to whatever you name your local newsgroups):

```
method tradspool {
  class: 1
  newsgroups: xyz.*
}
```

4. To make these changes effective, restart the news server.

Type `service innd restart` in Fedora or `/etc/init.d/innd restart` in Debian, SUSE, Ubuntu, and Xandros.)

Adding the newsgroups

The final step is to add the newsgroups. After you update the configuration files and run `innd`, adding a local newsgroup is easy. Log in as `root` and use `ctlinnd` to perform this task. For example, here's how you add a newsgroup named `xyz.general`:

```
/usr/lib/news/bin/ctlinnd newsgroup xyz.general
```

That's it! That command adds the `xyz.general` newsgroup to your site. If you use the traditional storage method, the `innd` server creates the directory `/var/spool/news/articles/xyz/general` the first time an article is posted and stores articles for that newsgroup in that directory.

After you create all the local newsgroups, users from your intranet can post news articles and read articles in the local newsgroups. If they have problems accessing the newsgroups, make sure that the `/etc/news/readers.conf` file contains the IP addresses or names of the hosts that have access to the `innd` server.

Testing your newsgroups

For example, add a newsgroup named `local.news` on an INN server running on your Linux system by using the instructions explained in the previous sections. Then start a newsreader and set up a new news account with the news server set to the INN server. Then access the `local.news` newsgroup. Try it! You'll like it

Chapter 6: Managing DNS

In This Chapter

- ✓ Understanding DNS
- ✓ Exploring BIND
- ✓ Finding out how to configure DNS
- ✓ Setting up a caching name server
- ✓ Configuring a primary name server

Domain Name System (DNS) is an Internet service that converts a fully qualified domain name, such as `www.debian.org`, into its corresponding IP address, such as `194.109.137.218`. You can think of DNS as the directory of Internet hosts — DNS is the reason why you can use easy-to-remember hostnames even though TCP/IP requires numeric IP addresses for data transfers. DNS is basically a hierarchy of distributed DNS servers. This chapter provides an overview of DNS and shows you how to set up a caching DNS server on your Linux system.

Understanding Domain Name System (DNS)

In TCP/IP networks, each network interface (for example, an Ethernet card or a dial-up modem connection) is identified by an IP address. Because IP addresses are hard to remember, an easy-to-remember name is assigned to the IP address — much like the way a name goes with a telephone number. For example, instead of having to remember that the IP address of Debian's web server is `194.109.137.218`, you can simply refer to that host by its name, `www.debian.org`. When you type `www.debian.org` as the URL in a web browser, the name `www.debian.org` is translated into its corresponding IP address. This process is where the concept of DNS comes in.

What is DNS?

Domain Name System is a distributed, hierarchical database that holds information about computers on the Internet. That information includes hostname, IP address, and mail-routing specifications. Because this information resides on many DNS hosts on the Internet, DNS is called a *distributed* database. The primary job of DNS is to associate hostnames to IP addresses and vice versa.

In ARPANET — the precursor to today's Internet — the list of hostnames and corresponding IP addresses was maintained in a text file named `HOSTS.TXT`, which was managed centrally and periodically distributed to every host on the

network. As the number of hosts grew, this static host table quickly became unreasonable to maintain. DNS was proposed by Paul Mockapetris to alleviate the problems of a static host table. As formally documented in Requests for Comment (RFCs) 882 and 883 (published in November 1983; see www.faqs.org/rfcs/rfc882.html and www.faqs.org/rfcs/rfc883.html), the original DNS introduced two key concepts:

- ◆ The use of hierarchical domain names, such as `www.ee.umd.edu` and `www.debian.org`
- ◆ The use of DNS servers throughout the Internet — a form of *distributed responsibility* — as a means of managing the host database

Today, DNS is an Internet standard documented that has been updated and extended. Earlier updates defined data encoding, whereas later ones focus on improving DNS security. To read these and other RFCs online, visit the RFC page at the Internet Engineering Task Force (IETF) website at www.ietf.org/rfc.html.

DNS defines the following:

- ◆ A hierarchical domain-naming system for hosts
- ◆ A distributed database that associates every domain name with an IP address
- ◆ Library routines (resolvers) that network applications can use to query the distributed DNS database (this library is called the *resolver library*)
- ◆ A protocol for DNS clients and servers to exchange information about names and IP addresses

Nowadays, all hosts on the Internet rely on DNS to access various Internet services on remote hosts. As you may know from experience, when you obtain Internet access from an Internet Service Provider (ISP), your ISP provides you with the IP addresses of *name servers* — the DNS servers your system accesses whenever hostnames are mapped to IP addresses.

If you have a small LAN, you may decide to run a DNS server on one of the hosts or use the name servers provided by the ISP. For medium-sized networks with several subnets, you can run a DNS server on each subnet to provide efficient DNS lookups. On a large corporate network, the corporate domain (such as `www.microsoft.com`) is further subdivided into a hierarchy of subdomains; several DNS servers may be used in each subdomain.

The following sections provide an overview of the hierarchical domain-naming convention and describe BIND — the DNS software used on most Unix systems, including Linux.

Discovering hierarchical domain names

DNS uses a hierarchical tree of domains to organize the *namespace* — the entire set of names. Each higher-level domain has authority over its lower-level subdomains. Each domain represents a distinct block of the namespace and is managed by a single administrative authority. Figure 6-1 illustrates the hierarchical organization of the DNS namespace.

Figure 6-1:
The DNS namespace is organized as a hierarchy.

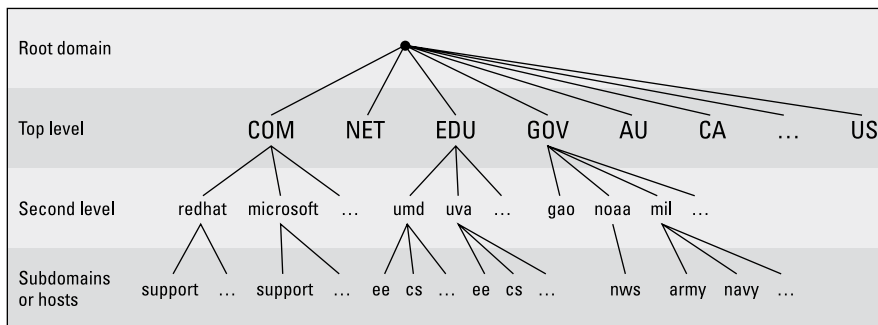

The root of the tree is called the *root domain* and is represented by a single dot (.). The top-level, or root-level, domains come next. The top-level domains are further divided into second-level domains, which, in turn, can be broken into further subdomains.

The top-level domains are relatively fixed and include well-known domains such as COM, NET, ORG, EDU, GOV, and MIL. These are the commonly used top-level domains in the United States. These top-level domains came about as the Internet came to widespread use in the early 1990s.

Another set of top-level domain names is for the countries. These domain names use the two-letter country codes assigned by the International Organization for Standardization (abbreviated as ISO, see www.iso.org). For example, the top-level country code domain for the United States is US. In the United States, many local governments and organizations use the US domain. For example, `mcps.k12.md.us` is the domain name of the Montgomery County Public Schools in the state of Maryland, in the United States.

To this list, you can add other generic top-level domain names that have been added since the original set. These include BIZ (for business), .NAME (for family names), .MUSEUM, .TRAVEL, and others (with more proposed on the way).

The *fully qualified domain name* (FQDN) is constructed by stringing together the subdomain names, from lower-level to higher-level, using a period (.) as a separator. For example, REDHAT.COM is a fully qualified domain name; so is EE.UMD.EDU. Note that each of these may also refer to a specific host computer. Figure 6-2 illustrates the components of a fully qualified domain name.

Figure 6-2:
A fully qualified domain name has a hierarchy of components.

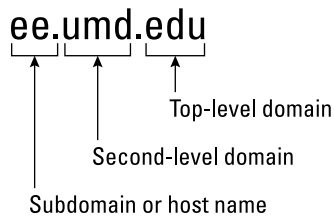

Domain names are case-insensitive. Therefore, as far as DNS is concerned, the domains `UMD.EDU` and `umd.edu` both represent University of Maryland's domain. The norm, however, is to type domain names in all lowercase.

Exploring Berkeley Internet Name Domain (BIND)

Most Unix systems, including Linux, come with the BIND system — a well-known implementation of DNS. The BIND software is installed during the Linux installation as long as you select the name server when selecting the packages for installation.



In Debian, Ubuntu, and Xandros, type **`dpkg -l bind*`** to see if BIND is installed. In Fedora and SUSE, type **`rpm -q bind`** and see if the BIND package is installed.

In Debian and Ubuntu, type **`apt-get install bind9`** to install BIND. In Fedora, log in as `root`, mount the DVD, and type **`cd /media/cdrom/Fedora/RPMS`** followed by **`rpm -ivh bind*`**. In SUSE, click Software Management in the YaST Control Center's Software category. Then use YaST's search facility to look for *bind*, select the relevant packages, and install them. In Xandros, first run Xandros Networks, choose Edit↔Set Application Sources, and click the Debian Unsupported Site link as a source. Then type **`apt-get install bind9`** to install the BIND server.

BIND includes three major components:

- ◆ The named daemon (the name server), which responds to queries about hostnames and IP addresses
- ◆ A resolver library that applications can use to resolve hostnames into IP addresses (and vice versa)
- ◆ Command-line DNS utility programs (DNS clients), such as `dig` (Domain Internet Groper) and `host`, that users can use to query DNS

The next few sections describe these components of BIND. Later sections explain how to configure the resolver and the name server.

named — the BIND name server

The named daemon is the name server that responds to queries about hostnames and IP addresses. Based on the configuration files and the local DNS database, named either provides answers to queries or asks other servers and

caches their responses. The `named` server also performs a function referred to as *zone transfer*, which involves copying data among the name servers in a domain.

The name server operates in one of three modes:

- ◆ **Primary, or master:** In this case, the name server keeps the master copy of the domain's data on disk. One primary server is for each domain or subdomain.
- ◆ **Secondary, or slave:** A secondary name server copies its domain's data from the primary server using a zone transfer operation. You can have one or more secondary name servers for a domain.
- ◆ **Caching:** A caching name server loads the addresses of a few authoritative servers for the root domain and gets all domain data by caching responses to queries it has resolved by contacting other name servers. Primary and secondary servers also cache responses.

A *name server* can be authoritative or not, depending on what information it's providing. As the term implies, the response from an authoritative name server is supposed to be accurate. The primary and secondary name servers are authoritative for their own domains, but they are not authoritative for responses provided from cached information.



Caching name servers are never authoritative because all their responses come from cached information.

To run a name server on your Linux system, you have to run `named` with the appropriate configuration files. Later in this chapter, you'll find out about the configuration files and data files that control how the name server operates.

Resolver library

Finding an IP address for a hostname is referred to as *resolving the hostname*. Network-aware applications, such as a web browser or an FTP client, use a *resolver library* to perform the conversion from the name to an IP address. Depending on the settings in the `/etc/host.conf` file, the resolver library consults the `/etc/hosts` file or makes a DNS query to resolve a hostname to its IP address. The resolver library queries the name servers listed in the `/etc/resolv.conf` file.

You don't have to know much about the resolver library unless you're writing network-aware applications. To run Internet services properly, all you have to know is how to configure the resolver. Later in this chapter, you will see how to configure the server and other aspects of DNS.

DNS utility programs

You can use the DNS utility programs — `dig` and `host` — to try out DNS interactively from the shell prompt. These utility programs are DNS clients. You can use them to query the DNS database and debug any name server set up on your system. By default, these programs query the name server listed in your system's `/etc/resolv.conf` file.

You can use `dig`, the Domain Internet Groper program, to look up IP addresses for a domain name or vice versa. For example, to look up the IP address of `ftp.redhat.com`, type

```
dig ftp.redhat.com
```

`dig` prints the results of the DNS query in great detail. Look in the part of the output labeled `ANSWER SECTION`: for the result. For example, here's what that section looks like for this sample query:

```
;; ANSWER SECTION:  
ftp.redhat.com. 300 IN A 209.132.183.61
```

This output means that the name `ftp.redhat.com` refers to the IP address `209.132.183.61`.

Reverse lookups (finding hostnames for IP addresses) are also easy with `dig`. For example, to find the hostname corresponding to the IP address `209.132.183.61`, type the following:

```
dig -x 209.132.183.61
```

Again, the answer appears in the `ANSWER SECTION` of the output, which, for this example, looks like this:

```
;; ANSWER SECTION:  
61.132.183.209.in-addr.arpa. 600 IN PTR ftp.redhat.com.
```

In this case, the hostname corresponding to the IP address `209.132.183.61` is `ftp.redhat.com`.

You can also query DNS by using the `host` program, which produces output in a compact format. For example, here's a typical use of `host` to look up an IP address for a hostname:

```
host www.gao.gov
```

This command generates the following output:

```
www.gao.gov has address 161.203.16.77  
www.gao.gov mail is handled by 5 listserv.gao.gov.
```

By default, `host` prints the IP address and any *MX record*. These records list the names of mail handlers for the host.

For a reverse lookup, use the `-t ptr` option along with the IP address as an argument, like this:

```
host -t ptr 161.203.16.2
```

Here's the relay from `host`:

```
2.16.203.161.in-addr.arpa domain name pointer www.gao.gov.
```

In this case, `host` prints the PTR record (from the DNS database) that shows the hostname corresponding to the IP address. (PTR refers to *pointer*, and the PTR record specifies the name corresponding to an address.)

You can also try other types of records, such as CNAME (for canonical name), as follows:

```
host -t cname www.ee.umd.edu
```

The response from `host` is

```
www.ee.umd.edu is an alias for ajclark.eng.umd.edu.
```

This output indicates that the *canonical name* (or alias) for `www.ee.umd.edu` is `ajclark.eng.umd.edu`.

Configuring DNS

You configure DNS by using a number of configuration files. The exact set of files depends on whether you're running a name server and, if so, the type of name server — caching or primary. Some configuration files are needed whether you run a name server or not.

Configuring the resolver

You don't need a name server running on your system to use the DNS clients (`dig` and `host`). You can use them to query your domain's name server. Typically, your ISP provides you with this information. You have to list the IP addresses of these name servers in the `/etc/resolv.conf` file — the resolver library reads this file to determine how to resolve hostnames. The format of this file is

```
domain your-domain.com
search your-domain.com
nameserver A.B.C.D
nameserver X.Y.Z.W
```

where *A.B.C.D* and *X.Y.Z.W* are the IP addresses (dot-separated numeric addresses, such as 192.168.0.1) of the primary and secondary name servers that your ISP provides you.

The `domain` line lists the local domain name. The `search` line specifies the domains on which a hostname is searched first (usually, you put your own domain in the `search` line). The domain listed on the `search` line is appended to any hostname before the resolver library tries to resolve it. For example, if you look for a host named `mailhost`, the resolver library first tries `mailhost.your-domain.com`; if that fails, it tries `mailhost`. The search line applies to any hostname that you try to access. For example, if you're trying to access `www.redhat.com`, the resolver first tries `www.redhat.com.your-domain.com` and then `www.redhat.com`.

Another important configuration file is `/etc/host.conf`. This file tells the resolver what to do when attempting to resolve a hostname. A typical `/etc/host.conf` file contains the following line:

```
order hosts,bind
```

This command tells the resolver to consult the `/etc/hosts` file first, and if the resolver does not find an entry there, query the name server listed in the `/etc/resolv.conf` file. The `/etc/hosts` file usually lists any local hostnames and their IP addresses. Here's a typical line from the `/etc/hosts` file:

```
127.0.0.1 lnp200 localhost.localdomain localhost
```

This line says that the IP address `127.0.0.1` is assigned to the hostnames `lnp200`, `localhost.localdomain`, and `localhost`.

In the latest version of the Linux kernel — the one that uses GNU C Library version 2 (`glibc 2`) or later — the name service switch (NSS) file, `/etc/nsswitch.conf`, controls how services such as the resolver library, NIS, NIS+, and local files such as `/etc/hosts` and `/etc/shadow` interact. For example, the following `hosts` entry in the `/etc/nsswitch.conf` file specifies that the resolver library first try the `/etc/hosts` file, then try NIS+, and finally try DNS:

```
hosts: files nisplus dns
```

To find more about the `/etc/nsswitch.conf` file, type **man nsswitch.conf** in a terminal window.

Configuring a caching name server

A *caching name server* is a simple-but-useful name server that finds answers to hostname queries (by using other name servers) and then remembers the answer (by saving it in a cache) for the next time you need it. This caching

```

allow-update { none; };
};
zone "255.in-addr.arpa" IN {
type master;
file "named.broadcast";
allow-update { none; };
};
zone "0.in-addr.arpa" IN {
type master;
file "named.zero";
allow-update { none; };
};
include "/etc/rndc.key";

```

Comments are C-style (`/* . . . */`) or C++-style (starts with `//`). The file contains block statements enclosed in curly braces (`{ . . . }`) and terminated by a semicolon (`;`). A block statement, in turn, contains other statements, each ending with a semicolon.

This `/etc/named.conf` file begins with an options block statement with a number of option statements. The `directory` option statement tells `named` where to look for all other files that appear on file lines in the configuration file. In this case, `named` looks for the files in the `/var/named` directory.



In SUSE, the `directory` option in `/etc/named.conf` refers to the `/var/lib/named` directory, which means that all other BIND configuration files are in `/var/lib/named`. In Debian and Xandros, the configuration files are explicitly specified to be in the `/etc/bind` directory.



The `controls` statement in `/etc/named.conf` contains security information so that the `rndc` command can connect to the `named` service at port 953 and interact with `named`. In this case, the `controls` statement contains the following line:

```
inet 127.0.0.1 allow { localhost; } keys { rndckey; };
```

This command says that `rndc` can connect from `localhost` with the key named `rndc`. (The file `/etc/rndc.key` defines the key and the encryption algorithm to be used.)



The `rndc` (remote name daemon control) utility is a successor to the older `ndc` (name daemon controller) utility used to control the `named` server by sending it messages over a special control channel, a TCP port where `named` listens for messages. The `rndc` utility uses a cryptographic key to authenticate itself to the `named` server. The `named` server has the same cryptographic key so that it can decode the authentication information sent by `rndc`.

After the `options` statement, the `/etc/named.conf` file contains several zone statements, each enclosed in curly braces and terminated by a semicolon. Each zone statement defines a zone. The first zone is named `.` (root zone); it's a hint zone that specifies the root name servers. (When the DNS

server starts, it uses the hint zone to find a root name server and get the most recent list of root name servers.)

The next two zone statements in `/etc/named.conf` are master zones. (A *master zone* is simply the master copy of data for a domain.) The syntax for a *master zone statement* for an Internet class zone (indicated by the `IN` keyword) is as follows:

```
zone "zone-name" IN {
type master;
file "zone-file";
[ . . . other optional statements . . . ]
};
```

zone-name is the name of the zone, and *zone-file* is the zone file that contains the resource records (RR) — the database entries — for that zone. The next two sections describe zone file formats and resource record formats.

Zone file formats

The zone file typically starts with a number of directives, each of which begins with a dollar sign (\$) followed by a keyword. Two commonly used directives are `$TTL` and `$ORIGIN`.

For example, the line

```
$TTL 86400
```

uses the `$TTL` directive to set the default Time To Live (TTL) for subsequent records with undefined TTLs. The value is in seconds, and the valid TTLs are in the range 0 to 2147483647 seconds. In this case, the directive sets the default TTL as 86400 seconds (or one day).

The `$ORIGIN` directive sets the domain name that is appended to any unqualified records. For example, the following `$ORIGIN` directive sets the domain name to `localhost`:

```
$ORIGIN localhost.
```

If there is no `$ORIGIN` directive, the initial `$ORIGIN` is the same as the zone name that comes after the zone keyword in the `/etc/named.conf` file.

After the directives, the zone file contains one or more resource records. These records follow a specific format, which are outlined in the next section.

Resource record (RR) formats

You have to understand the format of the resource records before you can understand and intelligently work with zone files. Each resource record (RR) has the following format. (Optional fields are shown in square brackets.)

```
[domain] [ttl] [class] type data [;comment]
```

The fields are separated by tabs or spaces and may contain some special characters, such as an @ for the domain and a semicolon (;) to indicate the start of a comment.

The first field, which must begin at the first character of the line, identifies the domain. You can use the @ to use the current \$ORIGIN for the domain name for this record. If you have multiple records for the same domain name, leave the first field blank.

The optional *ttl* field specifies the Time To Live — the duration for which the data can be cached and considered valid. You can specify the duration in one of the following formats:

- ◆ *N*, where *N* is the number of seconds
- ◆ *NW*, where *N* is the number of weeks
- ◆ *ND*, where *N* is the number of days
- ◆ *NH*, where *N* is the number of hours
- ◆ *MM*, where *N* is the number of minutes
- ◆ *NS*, where *N* is the number of seconds

The letters W, D, H, M, and S can also be lowercase. Thus you can write 86400 or 1D (or 1d) to indicate a duration of one day. You can also combine these letters to specify more precise durations, such as 5w6d16h to indicate 5 weeks, 6 days, and 16 hours.

The *class* field specifies the network type. The most commonly used value for this field is IN for Internet.

Next in the resource record is the *type* field, which denotes the type of record (such as SOA, NS, A, or PTR). Table 6-1 lists the DNS resource record types. The *data* field comes next, and its content depends on the *type* field.

| <i>Type</i> | <i>Name</i> | <i>Description</i> |
|-------------|---------------------------------|---|
| A | IPv4 to IPv6 Transition Address | Specifies the IPv6 address corresponding to a name using a format suitable for transition from IPv4 to IPv6 |
| AAAA | IPv6 Address | Specifies the IPv6 host address corresponding to a name |
| AS | Address | Specifies the IP address corresponding to a hostname |

| <i>Type</i> | <i>Name</i> | <i>Description</i> |
|-------------|---------------------|--|
| CERT | Digital Certificate | Holds a digital certificate |
| CNAME | Canonical Name | Defines the nickname or alias for a hostname |
| DNAME | Delegation Name | Replaces specified domain name with another name to be looked up |
| HINFO | Host Info | Identifies the hardware and operating system for a host |
| KEY | Public Key | Stores a public key associated with a DNS name |
| MX | Mail Exchanger | Identifies the host that accepts mail meant for a domain (used to route e-mail) |
| NS | Name Server | Identifies authoritative name servers for a zone |
| PTR | Pointer | Specifies the name corresponding to an address (used for <i>reverse mapping</i> —converting an IP address to a hostname) |
| RP | Responsible Person | Provides the name of a technical contact for a domain |
| SIG | Signature | Contains data authenticated in the secure DNS (see RFC 2535 for details) |
| SOA | Start of Authority | Indicates that all subsequent records are authoritative for this zone |
| SRV | Services | Lists well-known network services provided by the domain |
| TXT | Text | Includes comments and other information in the DNS database |

Read the resource records in the zone files, at least the ones of type SOA, NS, A, PTR, and MX, which are some of the most commonly used. (You'll find the zone files in the `/etc/bind` directory in Debian and Xandros, the `/var/` named directory in Fedora, and the `/var/lib/named` directory in SUSE.) Next there is a brief description of these records, illustrating each record type through an example.

A typical SOA record follows:

```
@ 1D IN SOA @ root (
42 ; serial
```

```
3H ; refresh -- 3 hours
15M ; retry -- 15 minutes
1W ; expiry -- 1 week
1D ) ; minimum -- 1 day
```

The first field specifies the domain as @, which means the current domain (by default, the zone name, as shown in the `/etc/named.conf` file). The next field specifies a TTL of one day for this record. The class field is set to IN, which means the record is for Internet. The type field specifies the record type as SOA. The rest of the fields constitute the data for the SOA record. The data includes the name of the primary name server (in this case, @, or the current domain), the e-mail address of the technical contact, and five times enclosed in parentheses.

The NS record specifies the authoritative name servers for a zone. A typical NS record looks like the following:

```
. 3600000 IN NS A.ROOT-SERVERS.NET.
```

In this case, the NS record lists the authoritative name server for the root zone. (Note that the name of the first field is a single period.) The Time To Live field specifies that the record is valid for 1,000 hours (3,600,000 seconds). The class is IN, for Internet; and the record type is NS. The final field lists the name of the name server (`A.ROOT-SERVERS.NET.`), which ends with a period.

An A record specifies the address corresponding to a name. For example, the following A record shows the address of `A.ROOT-SERVERS.NET.` as `198.41.0.4`:

```
A.ROOT-SERVERS.NET. 3600000 A 198.41.0.4
```

In this case, the network class isn't specified because the field is optional, and the default is IN.

PTR records are used for reverse mapping — converting an address to a name. Consider the following example:

```
1 IN PTR localhost.
```

This record comes from a file for a zone named `0.0.127.in-addr.arpa.` Therefore, this record says that the name associated with the address `127.0.0.1` is `localhost.`

An MX record specifies the name of a host that accepts mail on behalf of a specific domain. For example, here's a typical MX record:

```
Server7 IN MX 10 mailhub.lnbsoft.com.
```

This record says that mail addressed to the host named `server7` in the current domain is sent to `mailhub.lnbssoft.com`. (This host is called a *mail exchanger*.) The number `10` is the preference value. For a list of multiple `MX` records with different preference values, the ones with lower preference values are tried first.

Armed with this bit of information about resource records, you can go through the zone files for the caching name server.

The root zone file

There are 13 root name servers for the Internet; most root servers are located in the United States. Information about the 13 root name servers is in the zone file referenced in the `zone` statement for the root zone in the `/etc/named.conf` file. (The root zone file is `/var/named/named.ca` in Fedora, `/etc/bind/db.root` in Debian, Ubuntu, and Xandros, and `/var/lib/named/root.hint` in SUSE.) The following listing shows the root zone file:

```
; This file holds the information on root name servers needed to
; initialize cache of Internet domain name servers
; (e.g. reference this file in the "cache . <file>"
; configuration file of BIND domain name servers).
;
; This file is made available by InterNIC
; under anonymous FTP as
; file /domain/named.cache
; on server FTP.INTERNIC.NET
; -OR- RS.INTERNIC.NET
;
; last update: Jan 29, 2004
; related version of root zone: 2004012900
;
;
; formerly NS.INTERNIC.NET
;
. 3600000 IN NS A.ROOT-SERVERS.NET.
A.ROOT-SERVERS.NET. 3600000 A 198.41.0.4
;
; formerly NS1.ISI.EDU
;
. 3600000 NS B.ROOT-SERVERS.NET.
B.ROOT-SERVERS.NET. 3600000 A 192.228.79.201
;
; formerly C.PSI.NET
;
. 3600000 NS C.ROOT-SERVERS.NET.
C.ROOT-SERVERS.NET. 3600000 A 192.33.4.12
;
; formerly TERP.UMD.EDU
;
. 3600000 NS D.ROOT-SERVERS.NET.
D.ROOT-SERVERS.NET. 3600000 A 128.8.10.90
;
; formerly NS.NASA.GOV
;
. 3600000 NS E.ROOT-SERVERS.NET.
E.ROOT-SERVERS.NET. 3600000 A 192.203.230.10
;
```

```
; formerly NS.ISC.ORG
;
. 3600000 NS F.ROOT-SERVERS.NET.
F.ROOT-SERVERS.NET. 3600000 A 192.5.5.241
;
; formerly NS.NIC.DDN.MIL
;
. 3600000 NS G.ROOT-SERVERS.NET.
G.ROOT-SERVERS.NET. 3600000 A 192.112.36.4
;
; formerly AOS.ARL.ARMY.MIL
;
. 3600000 NS H.ROOT-SERVERS.NET.
H.ROOT-SERVERS.NET. 3600000 A 128.63.2.53
;
; formerly NIC.NORDU.NET
;
. 3600000 NS I.ROOT-SERVERS.NET.
I.ROOT-SERVERS.NET. 3600000 A 192.36.148.17
;
; operated by VeriSign, Inc.
;
. 3600000 NS J.ROOT-SERVERS.NET.
J.ROOT-SERVERS.NET. 3600000 A 192.58.128.30
;
; operated by RIPE NCC
;
. 3600000 NS K.ROOT-SERVERS.NET.
K.ROOT-SERVERS.NET. 3600000 A 193.0.14.129
;
; operated by ICANN
;
. 3600000 NS L.ROOT-SERVERS.NET.
L.ROOT-SERVERS.NET. 3600000 A 198.32.64.12
;
; operated by WIDE
;
. 3600000 NS M.ROOT-SERVERS.NET.
M.ROOT-SERVERS.NET. 3600000 A 202.12.27.33
; End of File
```

This file contains NS and A resource records that specify the names of authoritative name servers and their addresses for the root zone (indicated by the . in the first field of each NS record).

The comment lines in the file begin with a semicolon. These comments give you hints about the location of the 13 root name servers. This file is a necessity for any name server because the name server has to be able to reach at least one root name server.

The localhost.zone file

The `/etc/named.conf` file includes a zone statement for the `localhost` zone that specifies the zone file as `localhost.zone`. That file is located in the `/var/named` directory in Fedora, in the `/var/local/named` directory in SUSE, and in `/etc/bind/db.local` in Debian and Xandros. Here's a listing of what the `localhost.zone` file contains:

```

$TTL 86400
$ORIGIN localhost.
@ 1D IN SOA @ root (
42 ; serial (d. adams)
3H ; refresh
15M ; retry
1W ; expiry
1D ) ; minimum
1D IN NS @
1D IN A 127.0.0.1

```

This zone file starts with a `$TTL` directive that sets the default TTL (Time To Live) to one day (86400 seconds) for subsequent records with undefined TTLs. Next, the `$ORIGIN` directive sets the domain name to `localhost.`

After these two directives, the `localhost.zone` file contains three resource records (RRs): an SOA record, an NS record, and an A record. The SOA and NS records specify `localhost` as the primary authoritative name server for the zone. The A record specifies the address of `localhost` as `127.0.0.1`.

The zone file for reverse mapping 127.0.0.1

The third zone statement in the `/etc/named.conf` file specifies a reverse-mapping zone named `0.0.127.in-addr.arpa`. For this zone, the zone file is `/var/named/named.localhost` in Fedora, `/var/lib/named/127.0.0.1` zone in SUSE, and `/etc/bind/db.127` in Debian, Ubuntu, and Xandros. This zone file contains the following:

```

$TTL 86400
@ IN SOA localhost. root.localhost. (
1997022700 ; Serial
28800 ; Refresh
14400 ; Retry
3600000 ; Expire
86400 ) ; Minimum
IN NS localhost.
1 IN PTR localhost.

```

The SOA and NS records specify `localhost` as the primary name server. The PTR record specifies `localhost` as the name corresponding to the address `127.0.0.1`.

The SOA record also shows `root.localhost.` as the e-mail address of the technical contact for the domain. The DNS zone files use the format `user.host.` (note the ending period) format for the e-mail address. When sending any e-mail to the contact, you have to replace the first period with `@` and remove the final period.



Caching name server: Startup and test

After you've studied the configuration files for the caching name server, you can start the name server and see it in operation.



To start the name server, log in as `root` and type `/etc/init.d/named start` in Fedora and SUSE. To ensure that the named server starts every time you reboot the system, type `chkconfig -- level 35 named on` in Fedora and SUSE. In Debian, Ubuntu, and Xandros, type `/etc/init.d/bind9 start` to start the named server.

The named server writes diagnostic log messages in the `/var/log/messages` file. After you start named, you can check the log messages by opening `/var/log/messages` in a text editor. If no error messages are from named, you can proceed to test the name server.



Before you try the caching name server, you have to specify that name server as your primary one. To do so, make sure that the first line in the `/etc/resolv.conf` file is the following:

```
nameserver 127.0.0.1
```

Now you can use `host` to test the name server. For example, to look up the IP address of `www.gao.gov` by using the caching name server on `localhost`, type the following command:

```
host www.gao.gov localhost
```

Here's the resulting output from the `host` command:

```
Using domain server:
Name: localhost
Address: 127.0.0.1#53
Aliases:
www.gao.gov. has address 161.203.16.77
```

As the output shows, the `host` command uses `localhost` as the DNS server and returns the IP address of `www.gao.gov`. If you get output similar to this, the caching name server is up and running.

Configuring a primary name server

The best way to configure a primary name server is to start by configuring a caching name server (as explained in the previous sections). Then, add master zones for the domains for which you want this name server to be the primary name server. For example, suppose you want to define a primary name server for the `server7.net` domain. Here are the steps I go through to configure that primary name server on a Fedora system (after logging in as `root`):

1. Add the following zone statements to the `/etc/named.conf` file:

```
zone "server7.net" IN {
type master;
file "server7.zone";
```



```
};
zone "0.168.192.in-addr.arpa" IN {
type master;
file "0.168.192.zone";
};
```

- 2. Create the zone file /var/named/server7.zone with the following lines in it:**

```
$TTL 86400
$ORIGIN server7.net.
@ 1D IN SOA @ root.server7.net (
100 ; serial
3H ; refresh
15M ; retry
1W ; expiry
1D ) ; minimum
1D IN NS @
1D IN A 192.168.0.7
wxp IN A 192.168.0.2
```

- 3. Create the zone file /var/named/0.168.192.zone with the following lines in it:**

```
$TTL 86400
; Remember zone name is: 0.168.192.in-addr.arpa
@ IN SOA server7.net. root.server7.net (
1 ; Serial
28800 ; Refresh
14400 ; Retry
3600000 ; Expire
86400 ) ; Minimum
IN NS server7.net.
7 IN PTR server7.net.
2 IN PTR wxp.server7.net.
```

- 4. To test the new configuration, restart the named server with the following command:**

```
/etc/init.d/named restart
```

- 5. Use dig or host to query the DNS server.**

For example, here's how to use `host` to check the address of the host `wxp.server7.net` at the DNS server running on `localhost`:

```
host wxp.server7.net localhost
```

This command results in the following output:

```
Using domain server:
Name: localhost
Address: 127.0.0.1#53
Aliases:
wxp.server7.net has address 192.168.0.2
```

If you want to use `dig` to check the DNS server, type the following command:

```
dig @localhost wxp.server7.net
```

That `@localhost` part specifies the DNS server that `dig` contacts.

When you successfully use `dig` to contact a DNS server, you can get a bit fancier with what you ask that server to do. Here, for example, is the command to type to try a reverse lookup with the IP address `192.168.0.2`:

```
host 192.168.0.2 localhost
```

This command displays the following output:

```
Using domain server:  
Name: localhost  
Address: 127.0.0.1#53  
Aliases:  
2.0.168.192.in-addr.arpa domain name pointer wxp.server7.net
```

Book V

Administration

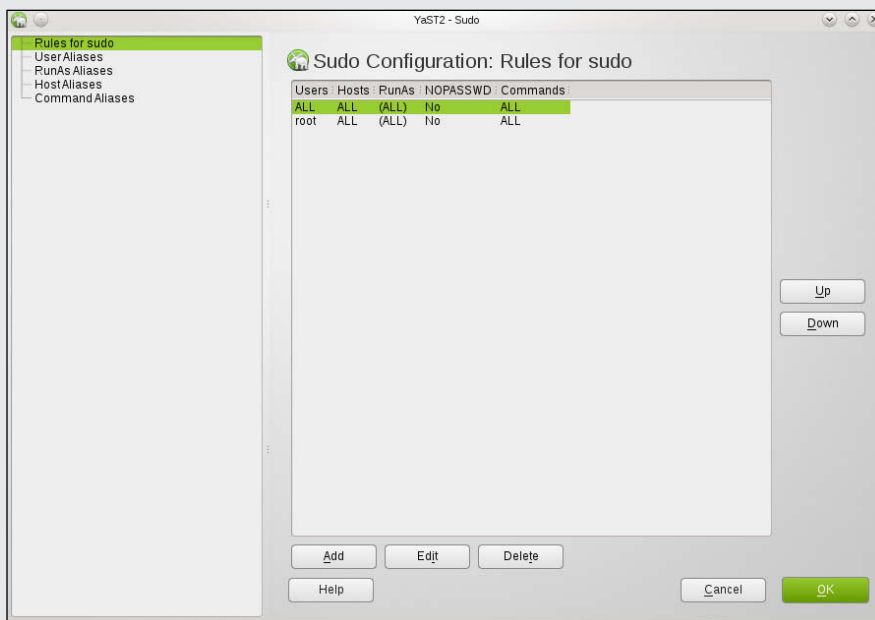

Visit www.dummies.com/extras/linuxaio for great Dummies content online.

Contents at a Glance

| | |
|---|------------|
| Chapter 1: Introducing Basic System Administration | 301 |
| Taking Stock of System Administration Tasks | 301 |
| Introducing Some GUI Sysadmin Tools..... | 303 |
| How to Become root | 305 |
| Understanding How Linux Boots..... | 308 |
| Taking Stock of Linux System Configuration Files..... | 314 |
| Monitoring System Performance | 317 |
| Viewing System Information with the /proc File System | 322 |
| Understanding Linux Devices | 325 |
| Managing Loadable Driver Modules..... | 328 |
| Scheduling Jobs in Linux..... | 330 |
| | |
| Chapter 2: Managing Users and Groups | 337 |
| Adding User Accounts..... | 337 |
| Understanding the /etc/passwd File..... | 343 |
| Managing Groups | 344 |
| Other User and Group Administration Values..... | 345 |
| Exploring the User Environment..... | 347 |
| Changing User and Group Ownership of Files..... | 350 |
| | |
| Chapter 3: Managing File Systems | 351 |
| Exploring the Linux File System..... | 351 |
| Sharing Files with NFS..... | 358 |
| Backing Up and Restoring Files | 361 |
| Accessing a DOS or Windows File System..... | 368 |
| | |
| Chapter 4: Working with Samba and NFS | 373 |
| Sharing Files with NFS..... | 373 |
| Setting Up a Windows Server Using Samba..... | 377 |

Chapter 1: Introducing Basic System Administration

In This Chapter

- ✓ **Introducing the GUI sysadmin tools**
- ✓ **Becoming root**
- ✓ **Understanding the system startup process**
- ✓ **Taking stock of the system configuration files**
- ✓ **Viewing system information through the /proc file system**
- ✓ **Monitoring system performance**
- ✓ **Managing devices**
- ✓ **Scheduling jobs**

System administration, or *sysadmin*, refers to whatever has to be done to keep a computer system up and running. The *system administrator* (the *sysadmin*) is whoever is in charge of taking care of these tasks.

If you're running Linux at home or in a small office, you're most likely the system administrator for your systems. Or maybe you're the system administrator for an entire LAN full of Linux systems. Regardless of your position or title, this chapter will introduce you to basic system administration procedures and show you how to perform some common tasks.

Taking Stock of System Administration Tasks

So what are system administration tasks? An off-the-cuff reply is *anything you have to do to keep the system running well*. More accurately, though, a system administrator's duties include

- ◆ **Adding and removing user accounts:** You have to add new user accounts and remove unnecessary user accounts. If a user forgets the password, you have to change the password.
- ◆ **Managing the printing system:** You have to turn the print queue on or off, check the print queue's status, and delete print jobs if necessary.
- ◆ **Installing, configuring, and upgrading the operating system and various utilities:** You have to install or upgrade parts of the Linux operating system and other software that are part of the operating system.

- ◆ **Installing new software:** You have to install software that comes in various package formats, such as RPM or DEB. You also have to download and unpack software that comes in source-code form — and then build executable programs from the source code.
- ◆ **Managing hardware:** Sometimes you have to add new hardware and install drivers so the devices work properly.
- ◆ **Making backups:** You have to back up files, whether to a DVD drive, a USB memory stick, an external hard drive, or tape.
- ◆ **Mounting and unmounting file systems:** When you want to access the files on a CD-ROM, for example, you have to mount that CD-ROM's file system on one of the directories in your Linux file system. You may also have to mount old floppy disks from the archive closet, in both Linux format and DOS format.
- ◆ **Automating tasks:** You have to schedule Linux tasks to take place automatically (at specific times) or periodically (at regular intervals).
- ◆ **Monitoring the system's performance:** You may want to keep an eye on system performance to see where the processor is spending most of its time and to see the amount of free and used memory in the system.
- ◆ **Starting and shutting down the system:** Although starting the system typically involves nothing more than powering up the PC, you do have to take some care when you shut down your Linux system. If your system is set up for a graphical login screen, you can perform the shutdown operation by choosing a menu item from the login screen. Otherwise, use the `shutdown` command to stop all programs before turning off your PC's power switch.
- ◆ **Monitoring network status:** If you have a network presence (whether a LAN, a DSL line, or a cable modem connection), you may want to check the status of various network interfaces and make sure your network connection is up and running.
- ◆ **Setting up host and network security:** You have to make sure that system files are protected and that your system can defend itself against attacks over the network.
- ◆ **Monitoring security:** You have to keep an eye on any intrusions, usually by checking the log files.

That's a long list of tasks! Not all these items are covered in this chapter, but the rest of this minibook describes most of these tasks. The focus in this chapter is on some of the basics, such as using the GUI tools, explaining how to become `root` (the superuser), describing the system configuration files, and showing you how to monitor system performance, manage devices, and set up periodic jobs.

Introducing Some GUI Sysadmin Tools

Each Linux distribution comes with GUI tools for performing system administration tasks. The GUI tools prompt you for input and then run the necessary Linux commands to perform the task. Although there are slight differences among them, the tools have become more and more uniform as time has passed.

For example, Figure 1-1 shows the YaST Control Center available in SUSE, and Figure 1-2 shows the System Settings interface in Ubuntu. Aside from YaST having more options, you should notice that there is great similarity between the interfaces.

Figure 1-1:
YaST
Control
Center is
your starting
point for
many
sysadmin
tasks in
SUSE.

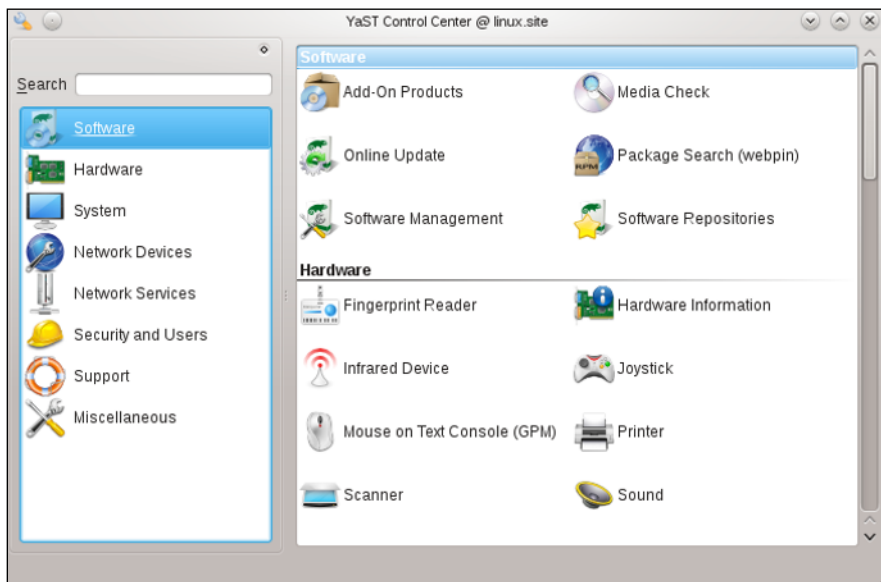

The left side of the YaST Control Center shows icons for the categories of tasks you can perform. The right side shows icons for specific tasks in the currently selected category. When you click an icon on the right side of the YaST Control Center, a new YaST window appears and enables you to perform that task.

As you can see from the entries in the YaST Control Center, it is truly meant to be a one-stop-shopping spot for all your sysadmin chores.

Figure 1-3 shows the Settings interface in Fedora and you can see that while the icons differ a bit from those found in the other distributions, most of the major chores an administrator deals with are capable of being addressed from here.

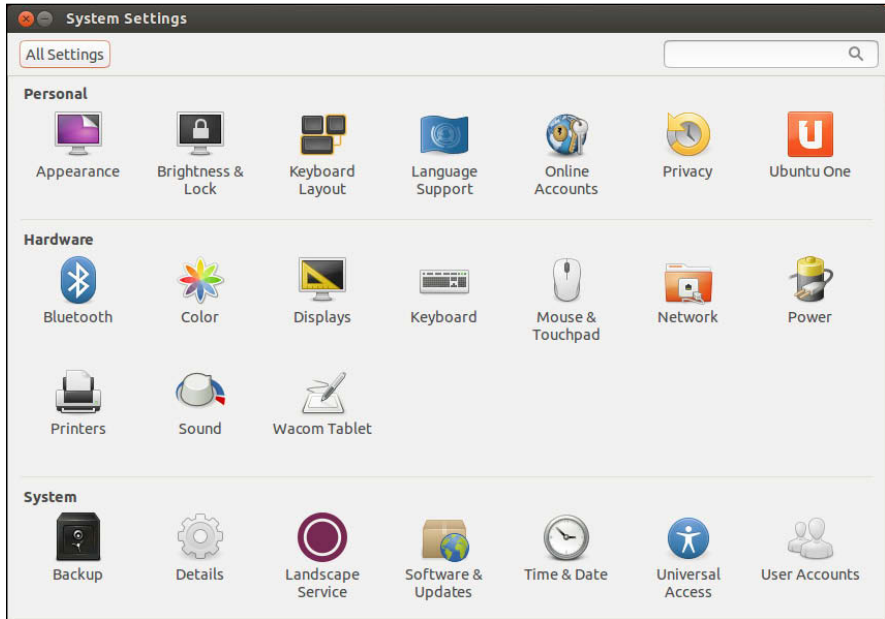

Figure 1-2: The Settings interface in Ubuntu offers many tools similar to those in YaST.

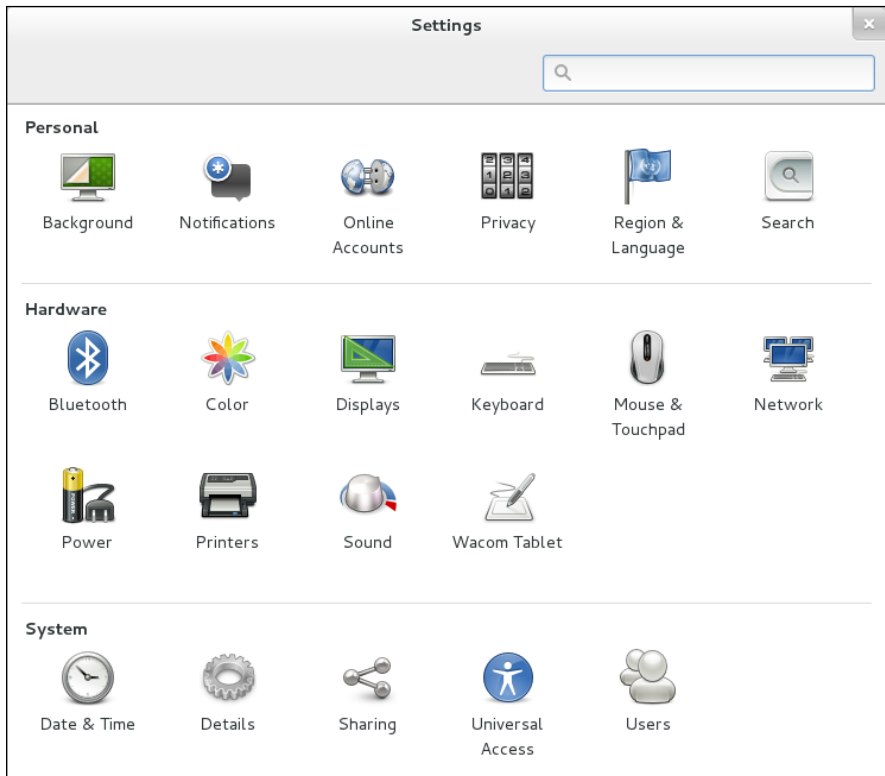

Figure 1-3: The Settings interface in Fedora differs a bit from Ubuntu.

Since YaST is the most complete of the lot, Table 1-1 lists the common tasks found in the Control Center.

| Table 1-1 | Tasks by Category in the YaST Control Center |
|----------------------|---|
| <i>This Category</i> | <i>Enables You to Configure or Manage the Following</i> |
| Software | Online Update, Installation Source, Installation in Xen Environment, Installation into Directory, Media Check, Patch CD Update, Software Management, System Update |
| Hardware | Bluetooth, CD-ROM Drives, Disk Controller, Graphics Card and Monitor, Hardware Information, IDE DMA Mode, Infrared Device, Joystick, Keyboard Layout, Mouse Model, Printer, Scanner, Sound, TV Card |
| System | <code>/etc/sysconfig</code> Editor, Boot Loader Configuration, Boot or Rescue, Date and Time, LVM, Language, PCI Device Drivers, Partitioner, Power Management, Powertweak, Profile Manager, System Backup, System Restoration, System Services (run level) |
| Network Devices | DSL, Fax, ISDN, Modem, Network Card, Phone Answering Machine |
| Network Services | DHCP Server, DNS Server, DNS Host and Name, HTTP Server, Host Names, Kerberos Client, LDAP Client, Mail Transfer Agent, NFS Client, NFS Server, NIS Client, NIS Server, NTP Client, Network Services (<code>xinetd</code>), Proxy, Remote Administration, Routing, SLP Browser, Samba Client, Samba Server, TFTP Server |
| Security and Users | Firewall, Group Management, Local Security, User Management |
| Support | Where you can find documentation and help resources |
| Miscellaneous | Autoinstallation, Post a Support Query, Vendor Driver CD, View Start-up Log, View System Log |

How to Become root

You have to log in as `root` to perform system administration tasks. The `root` user is the superuser and the only account with all the privileges needed to do anything in the system.

Common wisdom says you should *not* normally log in as `root`. When you're `root`, you can easily delete all the files with one misstep — especially when you're typing commands. For example, you type the command `rm *.html` to delete all files that have the `.html` extension. But what if you accidentally press the spacebar after the asterisk (*)? The shell takes the command to be `rm * .html` and — because `*` matches any filename — deletes everything in the current directory. Seems implausible until it happens to you!

Using the `su -` command

If you're logged in as a normal user, how do you do any system administration chores? Well, you become `root` for the time being. If you're working at a terminal window or console, type

```
su -
```

Then enter the `root` password in response to the prompt. From this point, you're `root`. Do whatever you have to do. To return to your usual self, type

```
exit
```

That's it! It's that easy.



By the way, Knoppix has a `root` user but doesn't have a `root` password, so you can become `root` by simply typing `su -` at the shell prompt in a terminal window. Also, Ubuntu doesn't have a `root` user. To perform any task that requires `root` privileges in Ubuntu, you must type `sudo` followed by the command and then provide your normal user password when prompted.

In the Security minibook, the issue will be addressed more, but you can control who can use `sudo` through configuration files (or the YaST interface, as Figure 1-4 shows).

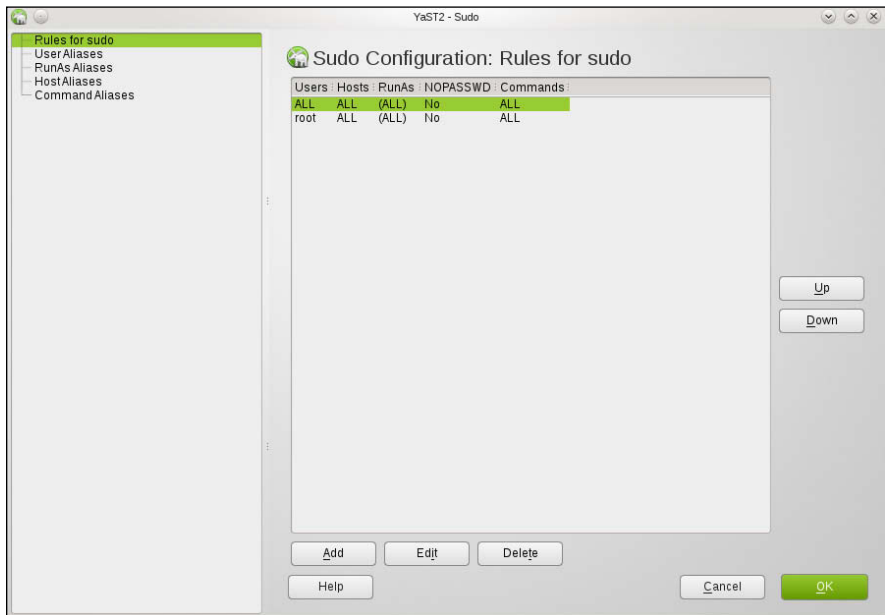

Figure 1-4:
Configuring
who can
use `sudo`.

Becoming root for the GUI utilities

Most Linux distributions include GUI utilities to perform system administration chores. If you use any of these GUI utilities to perform a task that requires you to be `root`, the utility typically pops up a dialog box that prompts you for the `root` password, as shown in Figure 1-5 (except in Ubuntu, where the GUI tools prompt for your normal user password). Just type the password and press Enter. If you don't want to use the utility, click Cancel.

Figure 1-5: Type the root password and press Enter to gain root privileges.



Recovering from a forgotten root password

To perform system administration tasks, you have to know the `root` password. What happens if you forget the `root` password? Not to worry. You can reset the `root` password by following these steps:

1. **Reboot the PC (select Reboot as you log out of the GUI screen) or power up as usual.**

As soon you see the graphical GRUB boot loader screen that shows the names of the operating systems, you can boot. If your system runs the LILO boot loader, press `Ctrl+X`, type **linux single** at the `boot :` prompt, and press Enter. Then proceed to Step 4. If you don't see the graphical loader screen on reboot, it might not be installed (which can occasionally occur when choosing to install from a Live CD). If this is the case, it is recommended that you reinstall from the CD.

2. **If you have more than one operating system installed, use the arrow key to select Linux as your operating system and then press the A key.**

GRUB prompts you for commands to add to its default boot command.

3. **Press the spacebar, and then type single and press Enter.**

Linux starts as usual but runs in a single-user mode that doesn't require you to log in. After Linux starts, you see the following command-line prompt similar to the following:

```
sh-3.00#
```

4. Type the `passwd` command to change the root password as follows:

```
sh-3.00# passwd
Changing password for user root.
New password:
```

5. Type the new root password that you want to use (it doesn't appear onscreen) and then press Enter.

Linux asks for the password again, like this:

```
Retype new password:
```

6. Type the password again and press Enter.

If you enter the same password both times, the `passwd` command changes the root password.

7. Now type `reboot` and press Enter to reboot the PC.

After Linux starts, it displays the familiar login screen. Now you can log in as `root` with the new password.



In SUSE Linux, in Step 3, type **`single init=/bin/sh`** (instead of **`single`**) and before proceeding to Step 4, at the command-line prompt, type **`mount / -n -o remount,rw`**. Then perform Steps 4 through 6 to change the `root` password. After changing the password, type **`mount / -n -o remount,ro`**. Then continue to Step 7 and reboot the PC.



Make sure that your Linux PC is *physically* secure. As these steps show, anyone who can physically access your Linux PC can simply reboot, set a new `root` password, and do whatever he or she wants with the system. Another way to protect against resetting the password is to set a GRUB password, which causes GRUB to require a valid password before it boots Linux. Of course, you must then remember to enter the GRUB password every time you boot your system!

Understanding How Linux Boots

Knowing the sequence in which Linux starts processes as it boots is important. You can use this knowledge to start and stop services, such as the web server and Network File System (NFS). The next few sections provide you with an overview of how Linux boots and starts the initial set of processes. These sections also familiarize you with the shell scripts that start various services on a Linux system.

Understanding the `init` process

When Linux boots, it loads and runs the core operating system program from the hard drive. The core operating system is designed to run other programs. A process named `init` starts the initial set of processes on your Linux system.

To see the processes currently running on the system, type

```
ps ax | more
```

You get an output listing that starts like this:

```
PID TTY STAT TIME COMMAND
1 ? S 0:22 init [2]
```

The first column, with the heading `PID`, shows a number for each process. *PID* stands for process ID (identification) — a sequential number assigned by the Linux kernel. The first entry in the process list, with a PID of 1, is the `init` process. It's the first process, and it starts all other processes in your Linux system. That's why `init` is sometimes referred to as the *mother of all processes*.

What the `init` process starts depends on

- ◆ **The run level**, an identifier that identifies a system configuration in which only a selected group of processes can exist.
- ◆ **The contents of the `/etc/inittab` file**, a text file that specifies which processes to start at different run levels.
- ◆ **A number of shell scripts that are executed at specific run levels.** (The scripts are located in the `/etc/init.d` directory and a number of subdirectories in `/etc` — these subdirectories have names that begin with `rc`.)



Most Linux distributions use seven run levels — 0 through 6. The meaning of the run levels differs from one distribution to another. Table 1-2 shows the meanings of the run levels and points out some of the actions specific to Fedora, Debian, SUSE, Ubuntu, and Xandros.

Table 1-2 Run Levels in Linux

| <i>Run Level</i> | <i>Meaning</i> |
|------------------|---|
| 0 | Shut down the system. |
| 1 | Run in single-user standalone mode (no one else can log in; you work at the text console). |
| 2 | Run in multiuser mode (Debian, Ubuntu, and Xandros use run level 2 as the default run level). |
| 3 | Run in full multiuser mode (used for text mode login in Fedora and SUSE). |
| 4 | Run in full multiuser mode (unused in Fedora and SUSE). |
| 5 | Run in full multiuser mode (used as the default run level with graphical login in Fedora and SUSE). |
| 6 | Reboot the system. |



The current run level together with the contents of the `/etc/inittab` file control which processes `init` starts in Linux. The default run level is 2 in Debian, Ubuntu, and Xandros. In Fedora and SUSE, run level 3 is used for text mode login screens and 5 for the graphical login screen. You can change the default run level by editing a line in the `/etc/inittab` file.

To check the current run level, type the following command in a terminal window:

```
/sbin/runlevel
```

In Debian, the `runlevel` command prints an output like this:

```
N 2
```

The first character of the output shows the previous run level (N means no previous run level), and the second character shows the current run level (2). In this case, the system started at run level 2. If you're in a GUI desktop in Fedora, the `runlevel` command should show 5 as the current run level.

Examining the `/etc/inittab` file

The `/etc/inittab` file is the key to understanding the processes that `init` starts at various run levels. You can look at the contents of the file by using the `more` command, as follows:

```
more /etc/inittab
```



To see the contents of the `/etc/inittab` file with the `more` command, you don't have to log in as `root`.

To interpret the contents of the `/etc/inittab` file, follow these steps:

- 1. Look for the line that contains the phrase `initdefault`.**

Here's that line from the `/etc/inittab` file from a Debian system:

```
id:2:initdefault:
```

That line shows the default run level. In this case, it's 2.

- 2. Find all the lines that specify what `init` runs at run level 2.**

Look for a line that has a 2 between the first two colons (:). Here's a relevant line in Debian:

```
l2:2:wait:/etc/init.d/rc 2
```

This line specifies that `init` executes the file `/etc/init.d/rc` with 2 as an argument.

If you look at the file `/etc/init.d/rc` in a Debian system, you find it's a shell script. You can study this file to see how it starts various processes for run levels 1 through 5.



Each entry in the `/etc/inittab` file tells `init` what to do at one or more run levels — you simply list all run levels at which the process runs. Each `inittab` entry has four fields — separated by colons — in the following format:

```
id:runlevels:action:process
```

Table 1-3 shows what each field means.

| <i>Field</i> | <i>Meaning</i> |
|------------------------|---|
| <code>id</code> | A unique one- or two-character identifier. The <code>init</code> process uses this field internally. You can use any identifier you want, as long as you don't use the same identifier on more than one line. |
| <code>runlevels</code> | A sequence of zero or more characters, each denoting a run level. For example, if the <code>runlevels</code> field is <code>12345</code> , that entry applies to each of the run levels 1 through 5. This field is ignored if the <code>action</code> field is set to <code>sysinit</code> , <code>boot</code> , or <code>bootwait</code> . |
| <code>action</code> | What the <code>init</code> process will do with this entry. If this field is <code>initdefault</code> , for example, <code>init</code> interprets the <code>runlevels</code> field as the default run level. If this field is set to <code>wait</code> , <code>init</code> starts the program or script specified in the <code>process</code> field and waits until that process exits. |
| <code>process</code> | Name of the script or program that <code>init</code> starts. Some settings of the <code>action</code> field require no <code>process</code> field. For example, when the <code>action</code> field is <code>initdefault</code> , there's no need for a <code>process</code> field. |

Trying a new run level with the `init` command

To try a new run level, you don't have to change the default run level in the `/etc/inittab` file. If you log in as `root`, you can change the run level (and, consequently, the processes that run in Linux) by typing **`init`** followed by the run level.

For example, to put the system in single-user mode, type the following:

```
init 1
```

Thus, if you want to try run level 3 without changing the default run level in `/etc/inittab` file, enter the following command at the shell prompt:

```
init 3
```

The system ends all current processes and enters run level 3. By default, the `init` command waits 20 seconds before stopping all current processes and starting the new processes for run level 3.



To switch to run level 3 immediately, type the command `init -t0 3`. The number after the `-t` option indicates the number of seconds `init` waits before changing the run level.

You can also use the `telinit` command, which is simply a symbolic link (a shortcut) to `init`. If you make changes to the `/etc/inittab` file and want `init` to reload its configuration file, use the command `telinit q`.

Understanding the Linux startup scripts

The `init` process runs a number of scripts at system startup. In the following discussions, a Debian system is used as an example, but the basic sequence is similar in other distributions — only the names and locations of the scripts may vary.



If you look at the `/etc/inittab` file in a Debian system, you find the following lines near the beginning of the file:

```
# Boot-time system configuration/initialization script.  
si::sysinit:/etc/init.d/rcS
```

The first line is a comment line. The second line causes `init` to run the `/etc/init.d/rcS` script — the first Linux startup script that `init` runs in a Debian system. The `rcS` script performs many initialization tasks, such as mounting the file systems, setting the clock, configuring the keyboard layout, starting the network, and loading many other driver modules. The `rcS` script performs these initialization tasks by calling many other scripts and reading configuration files located in the `/etc/rcS.d` directory.

After executing the `/etc/init.d/rcS` script, the `init` process runs the `/etc/init.d/rc` script with the run level as an argument. For example, for run level 2, the following line in `/etc/inittab` specifies what `init` executes:

```
l2:2:wait:/etc/init.d/rc 2
```

This example says `init` executes the command `/etc/init.d/rc 2` and waits until that command completes.

The `/etc/init.d/rc` script is somewhat complicated. Here's how it works:

- ◆ It executes scripts in a directory corresponding to the run level. For example, for run level 2, the `/etc/init.d/rc` script runs the scripts in the `/etc/rc2.d` directory.

- ◆ In the directory that corresponds with the run level, `/etc/init.d/rc` looks for all files that begin with `K` and executes each of them with the `stop` argument. This argument kills any currently running processes. Then it locates all files that begin with `S` and executes each file with a `start` argument. This argument starts the processes needed for the specified run level.

To see it executed at run level 2, type the following command:

```
ls -l /etc/rc2.d
```

In the resulting listing, the `K` scripts — the files whose names begin with `K` — stop (or *kill*) servers, whereas the `S` scripts start servers. The `/etc/init.d/rc` script executes these files in the order in which they appear in the directory listing.

Manually starting and stopping servers

In Linux, the server startup scripts reside in the `/etc/init.d` directory. You can manually invoke scripts in this directory to start, stop, or restart specific processes — usually servers. For example, to stop the FTP server (the server program is `vsftpd`), type the following command:

```
/etc/init.d/vsftpd stop
```

If `vsftpd` is already running and you want to restart it, type the following command:

```
/etc/init.d/vsftpd restart
```

You can enhance your system administration skills by familiarizing yourself with the scripts in the `/etc/init.d` directory. To see its listing, type the following command:

```
ls /etc/init.d
```

The script names give you some clue about which server the script can start and stop. For example, the `samba` script starts and stops the processes required for Samba Windows networking services. At your leisure, you may want to study some of these scripts to see what each one does. You don't have to understand all the shell programming; the comments help you discover the purpose of each script.

Automatically starting servers at system startup

You want some servers to start automatically every time you boot the system. The exact commands to configure the servers vary from one distribution to another.



In Fedora and SUSE, use the `chkconfig` command to set up a server to start whenever the system boots into a specific run level. For example, if you start the SSH server, you want the `sshd` server to start whenever the system starts. You can make that happen by using the `chkconfig` command. To set `sshd` to start whenever the system boots into run level 3, 4, or 5, type the following command (while logged in as `root`):

```
chkconfig --level 345 sshd on
```



In Fedora and SUSE, you can also use the `chkconfig` command to check which servers are turned on or off. For example, to see the complete list of all servers for all run levels, type the following command:

```
chkconfig --list
```



In Debian, Ubuntu, and Xandros, you can use the `update-rc.d` command to enable a server to start automatically at system startup. For example, to set `sshd` to start automatically at the default run levels, type **`update-rc.d sshd defaults`** in a terminal window while logged in as `root`. You can also specify the exact run levels and the sequence number (the order in which each server starts). To find out more about the `update-rc.d` command, type **`man update-rc.d`** in a terminal window.

Taking Stock of Linux System Configuration Files

Linux includes a host of configuration files. All these files share text files that you can edit with any text editor. To edit these configuration files, you must log in as `root`. A selection of the most popular configuration files appears in Table 1-4, along with a brief description of each. This table gives you an idea of what types of configuration files a system administrator has to work with. In many cases, Linux includes GUI utility programs to set up many of these configuration files.

| Configuration File | Description |
|----------------------------------|--|
| <code>/boot/grub</code> | Location of files for the GRUB boot loader. |
| <code>/boot/grub/menu.lst</code> | Configuration file for the boot menu that GRUB displays before it boots your system. |
| <code>/boot/System.map</code> | Map of the Linux kernel (maps kernel addresses into names of functions and variables). |
| <code>/boot/vmlinuz</code> | The Linux kernel (the operating system's core). |

| <i>Configuration File</i> | <i>Description</i> |
|---|--|
| <code>/etc/apache2/httpd.conf</code> | Configuration file for the Apache web server (Debian). |
| <code>/etc/apt/sources.list</code> | Configuration file that lists the sources — FTP or websites or CD-ROM — from which the Advanced Packaging Tool (APT) obtains packages (Debian, Ubuntu, and Xandros). |
| <code>/etc/at.allow</code> | Usernames of users allowed to use the <code>at</code> command to schedule jobs for later execution. |
| <code>/etc/at.deny</code> | Usernames of users forbidden to use the <code>at</code> command. |
| <code>/etc/bashrc</code> | System-wide functions and aliases for the <code>bash</code> shell (Fedora). |
| <code>/etc/bash.bashrc</code> | System-wide functions and aliases for the <code>bash</code> shell (Debian, SUSE, Ubuntu, and Xandros). |
| <code>/etc/cups/cupsd.conf</code> | Printer configuration file for the Common Unix Printing System (CUPS) scheduler. |
| <code>/etc/fonts</code> | Directory with font configuration files. (In particular, you can put local font configuration settings in the file <code>/etc/fonts/local.conf</code> .) |
| <code>/etc/fstab</code> | Information about file systems available for mounting and where each file system is to be mounted. |
| <code>/etc/group</code> | Information about groups. |
| <code>/etc/grub.conf</code> | The configuration for the GRUB boot loader in Fedora and SUSE. |
| <code>/etc/hosts</code> | List of IP numbers and their corresponding hostnames. |
| <code>/etc/hosts.allow</code> | Hosts allowed to access Internet services on this system. |
| <code>/etc/hosts.deny</code> | Hosts forbidden to access Internet services on this system. |
| <code>/etc/httpd/conf/httpd.conf</code> | Configuration file for the Apache web server (Fedora). |
| <code>/etc/init.d</code> | Directory with scripts to start and stop various servers. |
| <code>/etc/inittab</code> | Configuration file used by the <code>init</code> process that starts all the other processes. |

(continued)

Table 1-4 (continued)

| <i>Configuration File</i> | <i>Description</i> |
|-----------------------------------|--|
| <code>/etc/issue</code> | File containing a message to be printed before displaying the text mode login prompt (usually the distribution name and the version number). |
| <code>/etc/lilo.conf</code> | The configuration for the Linux Loader (LILO) — one of the boot loaders that can load the operating system from disk (present only if you use the LILO boot loader). |
| <code>/etc/login.defs</code> | Default information for creating user accounts, used by the <code>useradd</code> command. |
| <code>/etc/modprobe.conf</code> | Configuration file for loadable kernel modules, used by the <code>modprobe</code> command (Fedora and SUSE). |
| <code>/etc/modules.conf</code> | Configuration file for loadable modules (Debian and Xandros). |
| <code>/etc/mtab</code> | Information about currently mounted file systems. |
| <code>/etc/passwd</code> | Information about all user accounts. (Actual passwords are stored in <code>/etc/shadow</code> .) |
| <code>/etc/profile</code> | System-wide environment and startup file for the <code>bash</code> shell. |
| <code>/etc/profile.d</code> | Directory containing script files (with names that end in <code>.sh</code>) that the <code>/etc/profile</code> script executes. |
| <code>/etc/init.d/rcS</code> | Linux initialization script in Debian, SUSE, Ubuntu, and Xandros. |
| <code>/etc/rc.d/rc.sysinit</code> | Linux initialization script in Fedora. |
| <code>/etc/shadow</code> | Secure file with encrypted passwords for all user accounts (can be read by only <code>root</code>). |
| <code>/etc/shells</code> | List of all the shells on the system that the user can use. |
| <code>/etc/skel</code> | Directory that holds initial versions of files such as <code>.bash_profile</code> that copy to a new user's home directory. |
| <code>/etc/sysconfig</code> | Linux configuration files (Fedora and SUSE). |
| <code>/etc/sysctl.conf</code> | Configuration file with kernel parameters that are read in and set by <code>sysctl</code> at system startup. |
| <code>/etc/termcap</code> | Database of terminal capabilities and options (Fedora and SUSE). |

| <i>Configuration File</i> | <i>Description</i> |
|---------------------------------|--|
| <code>/etc/udev</code> | Directory containing configuration files for <code>udev</code> — the program that provides the ability to dynamically name hot-pluggable devices and create device files in the <code>/dev</code> directory. |
| <code>/etc/X11</code> | Directory with configuration files for the X Window System (X11) and various display managers such as <code>gdm</code> and <code>xdm</code> . |
| <code>/etc/X11/xorg.conf</code> | Configuration file for X.Org X11 — the X Window System (Fedora, Ubuntu, and SUSE). |
| <code>/etc/xinetd.conf</code> | Configuration for the <code>xinetd</code> daemon that starts a number of Internet services on demand. |
| <code>/etc/yum.conf</code> | Configuration for the <code>Yum</code> package updater and installer (Fedora). |
| <code>/var/log/apache2</code> | Web server access and error logs (Debian). |
| <code>/var/log/cron</code> | Log file with messages from the <code>cron</code> process that runs scheduled jobs. |
| <code>/var/log/boot.msg</code> | File with boot messages (SUSE). |
| <code>/var/log/dmesg</code> | File with boot messages (Debian, Fedora, Ubuntu, and Xandros). |
| <code>/var/log/httpd</code> | Web server access and error logs (Fedora). |
| <code>/var/log/messages</code> | System log. |

Monitoring System Performance

When you're the system administrator, you must keep an eye on how well your Linux system is performing. You can monitor the overall performance of your system by looking at information such as

- ◆ Central processing unit (CPU) usage
- ◆ Physical memory usage
- ◆ Virtual memory (swap-space) usage
- ◆ Hard drive usage

Linux comes with a number of utilities that you can use to monitor one or more of these performance parameters. The following sections introduce a few of these utilities and show you how to understand the information presented by said utilities.

Using the top utility

To view the top CPU processes — the ones that use most of the CPU time — you can use the text mode `top` utility. To start that utility, type **top** in a terminal window (or text console). The `top` utility then displays a text screen listing the current processes, arranged in the order of CPU usage, along with various other information, such as memory and swap-space usage. Figure 1-6 shows a typical output from the `top` utility.

```

ubuntu@ubuntu: ~
top - 17:41:15 up 51 min,  8 users,  load average: 0.96, 0.24, 0.12
Tasks: 201 total,  1 running, 200 sleeping,  0 stopped,  0 zombie
%Cpu(s):  1.3 us,  0.4 sy,  0.0 ni, 98.3 id,  0.0 wa,  0.0 hi,  0.0 si,  0.0 st
KiB Mem:  4019356 total, 1820440 used, 2198916 free,  258004 buffers
KiB Swap:   0 total,    0 used,    0 free, 1225472 cached

  PID USER      PR  NI  VIRT  RES  SHR  S  %CPU  %MEM    TIME+  COMMAND
 6377 ubuntu    20   0  291m  78m  32m  S   3.3   2.0   0:37.40 compiz
 6190 root      20   0 95896  19m 9988  S   2.7   0.5   0:29.29 Xorg
 8095 ubuntu    20   0  144m  15m  11m  S   2.3   0.4   0:02.09 gnome-terminal
 8341 ubuntu    20   0  132m  13m  10m  S   0.7   0.4   0:00.20 gnome-screensho
 6281 ubuntu    20   0  5788  2728  780  S   0.3   0.1   0:01.46 dbus-daemon
 6442 ubuntu    20   0 63576  11m 8788  S   0.3   0.3   0:01.42 gtk-window-deco
 8335 ubuntu    20   0  5208 1340  960  R   0.3   0.0   0:00.03 top
   1 root      20   0  3864 2256 1376  S   0.0   0.1   0:02.41 init
   2 root      20   0   0     0     0  S   0.0   0.0   0:00.00 kthreadd
   3 root      20   0   0     0     0  S   0.0   0.0   0:00.22 ksoftirqd/0
   5 root      0 -20   0     0     0  S   0.0   0.0   0:00.00 kworker/0:0H
   7 root      0 -20   0     0     0  S   0.0   0.0   0:00.00 kworker/u:0H
   8 root      rt    0   0     0     0  S   0.0   0.0   0:00.36 migration/0
   9 root      20   0   0     0     0  S   0.0   0.0   0:00.00 rcu_bh
  10 root      20   0   0     0     0  S   0.0   0.0   0:00.57 rcu_sched
  11 root      rt    0   0     0     0  S   0.0   0.0   0:00.00 watchdog/0
  12 root      rt    0   0     0     0  S   0.0   0.0   0:00.00 watchdog/1

```

Figure 1-6:
You can see the top CPU processes by using the `top` utility.



The `top` utility updates the display every five seconds. If you keep `top` running in a window, you can continually monitor the status of your Linux system. To quit `top`, press `Q` or `Ctrl+C` or close the terminal window.

The first five lines of the output screen (see Figure 1-6) provide summary information about the system, as follows:

- ◆ The first line shows the current time, how long the system has been up, how many users are logged in, and three *load averages* — the average number of processes ready to run during the last 1, 5, and 15 minutes.
- ◆ The second line lists the total number of processes and the status of these processes.
- ◆ The third line shows CPU usage — what percentage of CPU time is used by user processes, what percentage by system (kernel) processes, and during what percentage of time the CPU is idle.
- ◆ The fourth line shows how the physical memory is being used — the total amount, how much is used, how much is free, and how much is allocated to buffers (for reading from the hard drive, for example).

- ◆ The fifth line shows how the virtual memory (or swap space) is being used — the total amount of swap space, how much is used, how much is free, and how much is being cached.

The table that appears below the summary information (refer to Figure 1-6) lists information about the current processes, arranged in decreasing order by amount of CPU time used. Table 1-5 summarizes the meanings of the column headings in the table that `top` displays.

| <i>Heading</i> | <i>Meaning</i> |
|----------------|--|
| PID | Process ID of the process. |
| USER | Username under which the process is running. |
| PR | Priority of the process. |
| NI | Nice value of the process — the value ranges from -20 (highest priority) to 19 (lowest priority) and the default is 0. (The <i>nice value</i> represents the relative priority of the process: The higher the value, the lower the priority and the nicer the process because it yields to other processes.) |
| VIRT | Total amount of virtual memory used by the process, in kilobytes. |
| RES | Total physical memory used by a task (typically shown in kilobytes, but an <i>m</i> suffix indicates megabytes). |
| SHR | Amount of shared memory used by process. |
| S | State of the process (<i>S</i> for sleeping, <i>D</i> for uninterruptible sleep, <i>R</i> for running, <i>Z</i> for zombies — processes that should be dead but are still running — or <i>T</i> for stopped). |
| %CPU | Percentage of CPU time used since last screen update. |
| %MEM | Percentage of physical memory used by the process. |
| TIME+ | Total CPU time the process has used since it started. |
| COMMAND | Shortened form of the command that started the process. |

Using the uptime command

You can use the `uptime` command to get a summary of the system's state. Just type the command like this:

```
uptime
```

It displays output similar to the following:

```
15:03:21 up 32 days, 57 min, 3 users, load average: 0.13, 0.23, 0.27
```

This output shows the current time, how long the system has been up, the number of users, and (finally) the three load averages — the average number of processes that were ready to run in the past 1, 5, and 15 minutes. Load averages greater than 1 imply that many processes are competing for CPU time simultaneously.

The load averages give you an indication of how busy the system is.

Using the vmstat utility

You can get summary information about the overall system usage with the `vmstat` utility. To view system usage information averaged over 5-second intervals, type the following command (the second argument indicates the total number of lines of output `vmstat` displays):

```
vmstat 5 8
```

You see output similar to the following listing:

```
procs -----memory----- ---swap-- -----io----- --system-- -----cpu----
r b swpd free buff cache si so bi bo in cs us sy id wa
0 0 31324 4016 18568 136004 1 1 17 16 8 110 33 4 61 1
0 1 31324 2520 15348 139692 0 0 7798 199 1157 377 8 8 6 78
1 0 31324 1584 12936 141480 0 19 5784 105 1099 437 12 5 0 82
2 0 31324 1928 13004 137136 7 0 1586 138 1104 561 43 6 0 51
3 1 31324 1484 13148 132064 0 0 1260 51 1080 427 50 5 0 46
0 0 31324 1804 13240 127976 0 0 1126 46 1082 782 19 5 47 30
0 0 31324 1900 13240 127976 0 0 0 0 1010 211 3 1 96 0
0 0 31324 1916 13248 127976 0 0 0 10 1015 224 3 2 95 0
```

The first line of output shows the averages since the last reboot. After that, `vmstat` displays the 5-second average data seven more times, covering the next 35 seconds. The tabular output is grouped as six categories of information, indicated by the fields in the first line of output. The second line shows further details for each of the six major fields. You can interpret these fields by using Table 1-6.

| Table 1-6 | Meaning of Fields in the vmstat Utility's Output |
|-------------------|--|
| <i>Field Name</i> | <i>Description</i> |
| procs | Number of processes and their types: <code>r</code> = processes waiting to run, <code>b</code> = processes in uninterruptible sleep, <code>w</code> = processes swapped out but ready to run. |
| memory | Information about physical memory and swap-space usage (all numbers in kilobytes): <code>swpd</code> = virtual memory used, <code>free</code> = free physical memory, <code>buff</code> = memory used as buffers, <code>cache</code> = virtual memory that's cached. |

| Field Name | Description |
|------------|---|
| swap | Amount of swapping (the numbers are in kilobytes per second): <code>si</code> = amount of memory swapped in from disk, <code>so</code> = amount of memory swapped to disk. |
| io | Information about input and output. (The numbers are in blocks per second, where the block size depends on the disk device.) <code>bi</code> = rate of blocks sent to disk, <code>bo</code> = rate of blocks received from disk. |
| system | Information about the system: <code>in</code> = number of interrupts per second (including clock interrupts), <code>cs</code> = number of context switches per second — how many times the kernel changed which process was running. |
| cpu | Percentages of CPU time used: <code>us</code> = percentage of CPU time used by user processes, <code>sy</code> = percentage of CPU time used by system processes, <code>id</code> = percentage of time CPU is idle, <code>wa</code> = time spent waiting for input or output (I/O). |



In the `vmstat` utility's output, high values in the `si` and `so` fields indicate too much swapping. (*Swapping* refers to the copying of information between physical memory and the virtual memory on the hard drive.) High numbers in the `bi` and `bo` fields indicate too much disk activity.

Checking disk performance and disk usage

Linux comes with the `/sbin/hdparm` program to control IDE or ATAPI hard drives, which are common on most PCs. One feature of the `hdparm` program is that you can use the `-t` option to determine the rate at which data is read from the disk into a buffer in memory. For example, here's the result of typing `/sbin/hdparm -t /dev/hda` on one system:

```
/dev/hda:
Timing buffered disk reads: 178 MB in 3.03 seconds = 58.81 MB/sec
```

The command requires the IDE drive's device name (`/dev/hda` for the first hard drive and `/dev/hdb` for the second hard drive) as an argument. If you have an IDE hard drive, you can try this command to see how fast data is read from your system's disk drive.

To display the space available in the currently mounted file systems, use the `df` command. If you want a more readable output from `df`, type the following command:

```
df -h
```

322 *Viewing System Information with the /proc File System*

Here's a typical output from this command:

```
Filesystem Size Used Avail Use% Mounted on
/dev/hda5 7.1G 3.9G 2.9G 59% /
/dev/hda3 99M 18M 77M 19% /boot
none 125M 0 125M 0% /dev/shm
/dev/scd0 2.6G 2.6G 0 100% /media/cdrecorder
```

As this example shows, the `-h` option causes the `df` command to display the sizes in gigabytes (G) and megabytes (M).

To check the disk space being used by a specific directory, use the `du` command — you can specify the `-h` option to view the output in kilobytes (K) and megabytes (M), as shown in the following example:

```
du -h /var/log
```

Here's a typical output of that command:

```
152K /var/log/cups
4.0K /var/log/vbox
4.0K /var/log/httpd
508K /var/log/gdm
4.0K /var/log/samba
8.0K /var/log/mail
4.0K /var/log/news/OLD
8.0K /var/log/news
4.0K /var/log/squid
2.2M /var/log
```

The `du` command displays the disk space used by each directory, and the last line shows the total disk space used by that directory. If you want to see only the total space used by a directory, use the `-s` option. For example, type `du -sh /home` to see the space used by the `/home` directory. The command produces output that looks like this:

```
89M /home
```

Viewing System Information with the /proc File System

Your Linux system has a special `/proc` file system. You can find out many things about your system from this file system. In fact, you can even change kernel parameters through the `/proc` file system (just by writing to a file in that file system), thereby modifying the system's behavior.

The `/proc` file system isn't a real directory on the hard drive but a collection of data structures in memory, managed by the Linux kernel, that appears to you as a set of directories and files. The purpose of `/proc`

(also called the *process file system*) is to give you access to information about the Linux kernel as well as to help you find out about all processes currently running on your system.

You can access the /proc file system just as you access any other directory, but you have to know the meaning of various files to interpret the information. Typically, you can use the `cat` or `more` commands to view the contents of a file in /proc. The file's contents provide information about some aspect of the system.

As with any directory, start by looking at a detailed directory listing of /proc. To do so, log in as `root` and type `ls -l /proc` in a terminal window. In the output, the first set of directories (indicated by the letter `d` at the beginning of the line) represents the processes currently running on your system. Each directory that corresponds to a process has the process ID (a number) as its name.



Notice also a very large file named /proc/kcore; that file represents the *entire* physical memory of your system. Although /proc/kcore appears in the listing as a huge file, no single physical file occupies that much space on your hard drive — so don't try to remove the file to reclaim disk space.

Several files and directories in /proc contain interesting information about your Linux PC. The /proc/cpuinfo file, for example, lists the key characteristics of your system, such as processor type and floating-point processor information. You can view the processor information by typing `cat /proc/cpuinfo`. For example, here's what appears when `cat /proc/cpuinfo` is run on a sample system:

```
processor : 0
vendor_id : GenuineIntel
cpu family : 15
model : 3
model name : Intel(R) Celeron(R) CPU 2.53GHz
stepping : 3
cpu MHz : 2533.129
cache size : 256 KB
fdiv_bug : no
hlt_bug : no
f00f_bug : no
coma_bug : no
fpu : yes
fpu_exception : yes
cpuid level : 5
wp : yes
flags : fpu vme de pse tsc msr pae mce cx8 apic sep mtrr pge
        mca cmov pat pse36 clflush dts acpi mmx fxsr sse sse2 ss
        ht tm pbe pn1 monitor ds_cpl cid
bogomips : 4997.12
```

This output is from a 2.5-GHz Celeron system. The listing shows many interesting characteristics of the processor. Note the line that starts with `fdiv_bug`. Remember the infamous Pentium floating-point division bug? The bug is in an instruction called `fdiv` (for *floating-point division*). Thus, the `fdiv_bug` line indicates whether this particular Pentium has the bug.

The last line in the `/proc/cpuinfo` file shows the BogoMIPS for the processor, as computed by the Linux kernel when it boots. BogoMIPS is something that Linux uses internally to time-delay loops.

Table 1-7 summarizes some of the files in the `/proc` file system that provide information about your Linux system. You can view some of these files on your system to see what they contain, but note that not all files shown in Table 1-7 are present on your system. The specific contents of the `/proc` file system depend on the kernel configuration and the driver modules that are loaded (which, in turn, depend on your PC's hardware configuration).

| File Name | Content |
|--------------------------------|--|
| <code>/proc/acpi</code> | Information about Advanced Configuration and Power Interface (ACPI) — an industry-standard interface for configuration and power management on laptops, desktops, and servers. |
| <code>/proc/bus</code> | Directory with bus-specific information for each bus type, such as PCI. |
| <code>/proc/cmdline</code> | The command line used to start the Linux kernel (for example, <code>ro root=LABEL=/ rhgb</code>). |
| <code>/proc/cpuinfo</code> | Information about the CPU (the microprocessor). |
| <code>/proc/devices</code> | Available block and character devices in your system. |
| <code>/proc/dma</code> | Information about DMA (direct memory access) channels that are used. |
| <code>/proc/driver/rtc</code> | Information about the PC's real-time clock (RTC). |
| <code>/proc/filesystems</code> | List of supported file systems. |
| <code>/proc/ide</code> | Directory containing information about IDE devices. |
| <code>/proc/interrupts</code> | Information about interrupt request (IRQ) numbers and how they are used. |
| <code>/proc/ioports</code> | Information about input/output (I/O) port addresses and how they're used. |
| <code>/proc/kcore</code> | Image of the physical memory. |
| <code>/proc/kmsg</code> | Kernel messages. |

| <i>File Name</i> | <i>Content</i> |
|-------------------------------|--|
| <code>/proc/loadavg</code> | Load average (average number of processes waiting to run in the last 1, 5, and 15 minutes). |
| <code>/proc/locks</code> | Current kernel locks (used to ensure that multiple processes don't write to a file at the same time). |
| <code>/proc/meminfo</code> | Information about physical memory and swap-space usage. |
| <code>/proc/misc</code> | Miscellaneous information. |
| <code>/proc/modules</code> | List of loaded driver modules. |
| <code>/proc/mounts</code> | List of mounted file systems. |
| <code>/proc/net</code> | Directory with many subdirectories that contain information about networking. |
| <code>/proc/partitions</code> | List of partitions known to the Linux kernel. |
| <code>/proc/pci</code> | Information about PCI devices found on the system. |
| <code>/proc/scsi</code> | Directory with information about SCSI devices found on the system (present only if you have a SCSI device). |
| <code>/proc/stat</code> | Overall statistics about the system. |
| <code>/proc/swaps</code> | Information about the swap space and how much is used. |
| <code>/proc/sys</code> | Directory with information about the system. You can change kernel parameters by writing to files in this directory. (Using this method to tune system performance requires expertise to do properly.) |
| <code>/proc/uptime</code> | Information about how long the system has been up. |
| <code>/proc/version</code> | Kernel version number. |



You can navigate the `/proc` file system just as you'd work with any other directories and files in Linux. Use the `more` or `cat` commands to view the contents of a file.

Understanding Linux Devices

Linux treats all devices as files and uses a device just as it uses a file — opens it, writes data to it, reads data from it, and closes it when finished. This ability to treat every device as a file is possible because of *device drivers*, which are special programs that control a particular type of hardware. When the kernel writes data to the device, the device driver does whatever is appropriate for that device. For example, when the kernel writes data to the DVD drive, the DVD device driver puts that data onto the physical medium of the DVD disk.

Thus the device driver isolates the device-specific code from the rest of the kernel and makes a device look like a file. Any application can access a device by opening the file specific to that device.

Device files

Applications can access a device as if it were a file. These files, called *device files*, appear in the `/dev` directory in the Linux file system.

If you use the `ls` command to look at the list of files in the `/dev` directory, you see several thousand files. These files don't mean that your system has several thousand devices. The `/dev` directory has files for all possible types of devices — that's why the number of device files is so large.

So how does the kernel know which device driver to use when an application opens a specific device file? The answer is in two numbers called the *major* and *minor device numbers*. Each device file is mapped to a specific device driver through these numbers.

To see an example of the major and minor device numbers, type the following command in a terminal window:

```
ls -l /dev/hda
```

You see a line of output similar to the following:

```
brw-rw---- 1 root disk 3, 0 Aug 16 14:50 /dev/hda
```

In this line, the major and minor device numbers appear just before the date. In this case, the major device number is 3 and the minor device number is 0. The kernel selects the device driver for this device file by using the major device number.

You don't have to know much about device files and device numbers, except to be aware of their existence.



In case you're curious, all the major and minor numbers for devices are assigned according to device type. The Linux Assigned Names And Numbers Authority (LANANA) assigns these numbers. You can see the current device list at www.lanana.org/docs/device-list/devices-2.6+.txt.

Block devices

The first letter in the listing of a device file also provides an important clue. For the `/dev/hda` device, the first letter is `b`, which indicates that `/dev/hda` is a *block device* — one that can accept or provide data in chunks (typically 512 bytes or 1K). By the way, `/dev/hda` refers to the first IDE hard drive on your system (the C: drive in Windows). Hard drives and CD-ROM drives are examples of block devices.

Character devices

If the first letter in the listing of a device file is *c*, the device is a *character device* — one that can receive and send data one character (one byte) at a time. For example, the serial port and parallel ports are character devices. To see the specific listing of a character device, type the following command in a terminal window:

```
ls -l /dev/ttyS0
```

The listing of this device is similar to the following:

```
crw-rw---- 1 root uucp 4, 64 Aug 16 14:50 /dev/ttyS0
```

Note that the very first letter is *c* because `/dev/ttyS0` — the first serial port — is a character device.

Network devices

Network devices that enable your system to interact with a network — for example, Ethernet and dial-up *Point-to-Point Protocol* (PPP) connections — are special because they need no file to correspond to the device. Instead, the kernel uses a special name for the device. For example, Ethernet devices are named `eth0` for the first Ethernet card, `eth1` for the second one, and so on. PPP connections are named `ppp0`, `ppp1`, and so on.

Because network devices aren't mapped to device files, no files corresponding to these devices are in the `/dev` directory.

Persistent device naming with udev

Starting with the Linux kernel 2.6, a new approach for handling devices was added, based on the following features:

- ◆ **sysfs:** The kernel provides the `sysfs` file system, which is mounted on the `/sys` directory of the file system. The `sysfs` file system displays all the devices in the system as well as lots of information about each device, including the location of the device on the bus, attributes such as name and serial number, and the major and minor numbers of the device.
- ◆ **/sbin/hotplug:** This program is called whenever a device is added or removed. It can then do whatever is necessary to handle the device.
- ◆ **/sbin/udev:** This program takes care of dynamically named devices based on device characteristics such as serial number, device number on a bus, or a user-assigned name based on a set of rules that are set through the text file `/etc/udev/udev.rules`.



The udev program's configuration file is `/etc/udev/udev.conf`. Based on settings in that configuration file, udev creates device nodes automatically in the directory specified by the `udev_root` parameter. For example, to manage the device nodes in the `/dev` directory, `udev_root` should be defined in `/etc/udev/udev.conf` as follows:

```
udev_root="/dev/"
```

Managing Loadable Driver Modules

To use any device, the Linux kernel must contain the driver. If the driver code is linked into the kernel as a *monolithic* program (a program in the form of a single, large file), adding a new driver means rebuilding the kernel with the new driver code. Rebuilding the kernel means you have to reboot the PC with the new kernel before you can use the new device driver. Luckily, the Linux kernel uses a modular design that does away with rebooting hassles. Linux device drivers can be created in the form of modules that the kernel can load and unload without having to restart the PC.



Driver modules are one type of a broader category of software modules called *loadable kernel modules*. Other types of kernel modules include code that can support new types of file systems, modules for network protocols, and modules that interpret different formats of executable files.

Loading and unloading modules

You can manage the loadable device driver modules by using a set of commands. You have to log in as `root` to use some of these commands. Table 1-8 summarizes a few commonly used module commands.

Table 1-8 **Commands to Manage Kernel Modules**

| <i>This Command</i> | <i>Does the Following</i> |
|-----------------------|---|
| <code>insmod</code> | Inserts a module into the kernel. |
| <code>rmmmod</code> | Removes a module from the kernel. |
| <code>depmod</code> | Determines interdependencies between modules. |
| <code>ksyms</code> | Displays a list of symbols along with the name of the module that defines the symbol. |
| <code>lsmod</code> | Lists all currently loaded modules. |
| <code>modinfo</code> | Displays information about a kernel module. |
| <code>modprobe</code> | Inserts or removes a module or a set of modules intelligently. (For example, if module A requires B, <code>modprobe</code> automatically loads B when asked to load A.) |

If you have to use any of these commands, log in as `root` or type `su` - in a terminal window to become `root`.

To see what modules are currently loaded, type

```
lsmod
```

You see a long list of modules. The list that you see will depend on the types of devices installed on your system.

The list displayed by `lsmod` includes all types of Linux kernel modules, not just device drivers. For example, if you use the Ext3 file system, you typically find two modules — `jbd` and `ext3` — that are part of the Ext3 file system (the latest file system for Linux).



Besides `lsmod`, one commonly used module command is `modprobe`. Use `modprobe` when you need to manually load or remove one or more modules. The best thing about `modprobe` is that you don't need to worry if a module requires other modules to work. The `modprobe` command automatically loads any other module needed by a module. For example, to manually load the sound driver, use the command

```
modprobe snd-card-0
```

This command causes `modprobe` to load everything needed to make sound work.



You can use `modprobe` with the `-r` option to remove modules. For example, to remove the sound modules, use the following command:

```
modprobe -r snd-card-0
```

This command gets rid of all the modules that the `modprobe snd-card-0` command had loaded.

Using the `/etc/modprobe.conf` file

How does the `modprobe` command know that it needs to load the `snd-intel8x0` driver module? The answer's in the `/etc/modprobe.conf` configuration file. That file contains a line that tells `modprobe` what it should load when it sees the module name `snd-card-0`.

To view the contents of `/etc/modprobe.conf`, type

```
cat /etc/modprobe.conf
```

For example, consider a `/etc/modprobe.conf` file that contains the following lines:

```
alias eth0 3c59x
alias snd-card-0 snd-intel8x0
alias usb-controller uhci-hcd
```

Each line that begins with the keyword `alias` defines a standard name for an actual driver module. For example, the first line defines `3c59x` as the actual driver name for the alias `eth0`, which stands for the first Ethernet card. Similarly, the second line defines `snd-intel8x0` as the module to load when the user uses the name `snd-card-0`.

The `modprobe` command consults the `/etc/modprobe.conf` file to convert an alias to the real name of a driver module. It also consults the `/etc/modprobe.conf` file for other tasks, such as obtaining parameters for driver modules. For example, you can insert lines that begin with the options keyword to provide values of parameters that a driver may need.

For example, to set the debug-level parameter for the Ethernet driver to 5 (this parameter generates lots of information in `/var/log/messages`), add the following line to the `/etc/modprobe.conf` file:

```
options 3c59x debug=5
```

This line specifies 5 as the value of the `debug` parameter in the `3c59x` module.

If you want to know the names of the parameters that a module accepts, use the `modinfo` command. For example, to view information about the `3c59x` driver module, type

```
modinfo 3c59x | more
```

From the resulting output, it's possible to tell that `debug` is the name of the parameter for setting the debug level.

Unfortunately, the information displayed by the `modinfo` command can be cryptic. The only saving grace is that you may not have to do much more than use a graphical utility to configure the device, and the utility takes care of adding whatever is needed to configuration files, such as `/etc/modprobe.conf`.

Scheduling Jobs in Linux

As a system administrator, you may have to run some programs automatically at regular intervals or execute one or more commands at a specified time in the future. Your Linux system includes the facilities to schedule jobs

to run at any future date or time you want. You can also set up the system to perform a task periodically or just once. Here are some typical tasks you can perform by scheduling jobs on your Linux system:

- ◆ Back up the files in the middle of the night
- ◆ Download large files in the early morning when the system isn't busy
- ◆ Send yourself messages as reminders of meetings
- ◆ Analyze system logs periodically and look for any abnormal activities

You can set up these jobs by using the `at` command or the `crontab` facility of Linux. The next few sections introduce these job-scheduling features of Linux.

Scheduling one-time jobs

If you want to run one or more commands at a later time, you can use the `at` command. The `atd` daemon — a program designed to process jobs submitted using `at` — runs your commands at the specified time and mails the output to you.



Before you try the `at` command, you need to know that the following configuration files control which users can schedule tasks using the `at` command:

- ◆ `/etc/at.allow` contains the names of the users who may submit jobs using the `at` command.
- ◆ `/etc/at.deny` contains the names of users not allowed to submit jobs using the `at` command.

If these files aren't present or if you find an empty `/etc/at.deny` file, any user can submit jobs by using the `at` command. The default in Linux is an empty `/etc/at.deny` file; with this default in place, anyone can use the `at` command. If you don't want some users to use `at`, simply list their usernames in the `/etc/at.deny` file.

To use `at` to schedule a one-time job for execution at a later time, follow these steps:

1. Run the `at` command with the date or time when you want your commands executed.

When you press Enter, the `at>` prompt appears, as follows:

```
at 21:30
at>
```

This method is the simplest way to indicate the time when you want to execute one or more commands — simply specify the time in a 24-hour format. In this case, you want to execute the commands at 9:30 p.m. tonight (or tomorrow, if it's already past 9:30 p.m.). You can, however, specify the execution time in many different ways. (See Table 1-9 for examples.)

2. At the `at>` prompt, type the commands you want to execute as if you were typing at the shell prompt. After each command, press Enter and continue with the next command. When you finish entering the commands you want to execute, press Ctrl+D to indicate the end.

Here's an example that shows how to execute the `ps` command at a future time:

```
at> ps
at> <EOT>
job 1 at 2014-12-28 21:30
```

After you press Ctrl+D, the `at` command responds with the `<EOT>` message, a job number, and the date and time when the job will execute.

Table 1-9 Formats for the `at` Command for the Time of Execution

| <i>Command</i> | <i>When the Job Will Run</i> |
|-----------------------------------|--|
| <code>at now</code> | Immediately |
| <code>at now + 15 minutes</code> | 15 minutes from the current time |
| <code>at now + 4 hours</code> | 4 hours from the current time |
| <code>at now + 7 days</code> | 7 days from the current time |
| <code>at noon</code> | At noontime today (or tomorrow, if already past noon) |
| <code>at now next hour</code> | Exactly 60 minutes from now |
| <code>at now next day</code> | At the same time tomorrow |
| <code>at 17:00 tomorrow</code> | At 5:00 p.m. tomorrow |
| <code>at 4:45pm</code> | At 4:45 p.m. today (or tomorrow, if it's already past 4:45 p.m.) |
| <code>at 3:00 Dec 28, 2014</code> | At 3:00 a.m. on December 28, 2014 |

After you enter one or more jobs, you can view the current list of scheduled jobs with the `atq` command:

```
atq
```

The output looks similar to the following:

```
4 2014-12-28 03:00 a root
5 2014-10-26 21:57 a root
6 2014-10-26 16:45 a root
```

The first field on each line shows the job number — the same number that the `at` command displays when you submit the job. The next field shows the year, month, day, and time of execution. The last field shows the jobs pending in the `a` queue.

If you want to cancel a job, use the `atrm` command to remove that job from the queue. When removing a job with the `atrm` command, refer to the job by its number, as follows:

```
atrm 4
```

This command deletes job 4 scheduled for 3:00 a.m. December 28, 2014.

When a job executes, the output is mailed to you. Type **mail** at a terminal window to read your mail and to view the output from your jobs.



Scheduling recurring jobs

Although `at` is good for running commands at a specific time, it's not useful for running a program automatically at repeated intervals. You have to use `crontab` to schedule such recurring jobs — for example, if you want to back up your files to tape at midnight every evening.

You schedule recurring jobs by placing job information in a file with a specific format and submitting this file with the `crontab` command. The `cron` daemon — `crond` — checks the job information every minute and executes the recurring jobs at the specified times. Because the `cron` daemon processes recurring jobs, such jobs are also referred to as *cron jobs*.

Any output from a `cron` job is mailed to the user who submits the job. (In the submitted job-information file, you can specify a different recipient for the mailed output.)

Two configuration files control who can schedule `cron` jobs using `crontab`:

- ◆ `/etc/cron.allow` contains the names of the users who may submit jobs using the `crontab` command.
- ◆ `/etc/cron.deny` contains the names of users not allowed to submit jobs using the `crontab` command.

If the `/etc/cron.allow` file exists, only users listed in this file can schedule `cron` jobs. If only the `/etc/cron.deny` file exists, users listed in this file can't schedule `cron` jobs. If neither file exists, the default Linux setup enables any user to submit `cron` jobs.

To submit a `cron` job, follow these steps:

1. **Prepare a shell script (or an executable program in any programming language) that can perform the recurring task you want to perform.**

You can skip this step if you want to execute an existing program periodically.

2. **Prepare a text file with information about the times when you want the shell script or program (from Step 1) to execute and then submit this file by using `crontab`.**

You can submit several recurring jobs with a single file. Each line with timing information about a job has a standard format, with six fields — the first five specify when the job runs, and the sixth and subsequent fields constitute the command that runs. For example, here's a line that executes the `myjob` shell script in a user's home directory at five minutes past midnight each day:

```
5 0 * * * $HOME/myjob
```

Table 1-10 shows the meaning of the first five fields. **Note:** An asterisk (*) means all possible values for that field. Also, an entry in any of the first five fields can be a single number, a comma-separated list of numbers, a pair of numbers separated by a hyphen (indicating a range of numbers), or an asterisk.

3. **Suppose the text file `jobinfo` (in the current directory) contains the job information. Submit this information to `crontab` with the following command:**

```
crontab jobinfo
```

That's it! You're set with the `cron` job. From now on, the `cron` job runs at regular intervals (as specified in the job-information file), and you receive mail messages with the output from the job.

To verify that the job is indeed scheduled, type the following command:

```
crontab -l
```

The output of the `crontab -l` command shows the `cron` jobs currently installed in your name. To remove your `cron` jobs, type **`crontab -r`**.

If you log in as `root`, you can also set up, examine, and remove `cron` jobs for any user. To set up `cron` jobs for a user, use this command:

```
crontab _u username filename
```

Here *username* is the user for whom you install the `cron` jobs, and *filename* is the file that contains information about the jobs.

Table 1-10 Format for the Time of Execution in crontab Files

| <i>Field Number</i> | <i>Meaning of Field</i> | <i>Acceptable Range of Values*</i> |
|---------------------|-------------------------|---|
| 1 | Minute | 0–59 |
| 2 | Hour of the day | 0–23 |
| 3 | Day of the month | 0–31 |
| 4 | Month | 1–12 (1 means January, 2 means February, and so on) or the names of months using the first three letters — Jan, Feb, Mar, Apr, May, Jun, Jul, Aug, Sep, Oct, Nov, Dec |
| 5 | Day of the week | 0–6 (0 means Sunday, 1 means Monday, and so on) or the three-letter abbreviations of weekdays — Sun, Mon, Tue, Wed, Thu, Fri, Sat |

* An asterisk in a field means all possible values for that field. For example, if an asterisk is in the third field, the job is executed every day.

Use the following form of crontab command to view the cron jobs for a user:

```
crontab _u username -l
```

To remove a user's cron jobs, use the following command:

```
crontab -u username -r
```

Note: The cron daemon also executes the cron jobs listed in the system-wide cron job file `/etc/crontab`. Here's a typical `/etc/crontab` file from a Linux system (type `cat /etc/crontab` to view the file):

```
SHELL=/bin/bash
PATH=/sbin:/bin:/usr/sbin:/usr/bin
MAILTO=root
HOME=/
# run-parts
01 * * * * root run-parts /etc/cron.hourly
02 4 * * * root run-parts /etc/cron.daily
22 4 * * 0 root run-parts /etc/cron.weekly
42 4 1 * * root run-parts /etc/cron.monthly
```

The first four lines set up several environment variables for the jobs listed in this file. The `MAILTO` environment variable specifies the user who receives the mail message with the output from the cron jobs in this file.

The line that begins with # is a comment line. The four lines following the `run-parts` comment execute the `run-parts` shell script (located in the `/usr/bin` directory) at various times with the name of a specific directory as argument. Each of the arguments to `run-parts` — `/etc/cron.hourly`, `/etc/cron.daily`, `/etc/cron.weekly`, and `/etc/cron.monthly` — are directories. Essentially, `run-parts` executes all scripts located in the directory that you provide as an argument.

Table 1-11 lists the directories where you can find these scripts and when they execute. You have to look at the scripts in these directories to know what executes at these periodic intervals.

| <i>Directory Name</i> | <i>Script Executes</i> |
|--------------------------------|------------------------|
| <code>/etc/cron.hourly</code> | Every hour |
| <code>/etc/cron.daily</code> | Each day |
| <code>/etc/cron.weekly</code> | Weekly |
| <code>/etc/cron.monthly</code> | Once each month |

Chapter 2: Managing Users and Groups

In This Chapter

- ✓ **Managing a user account with a GUI user manager and commands**
- ✓ **Understanding the password file**
- ✓ **Managing your groups**
- ✓ **Working in the user environment**
- ✓ **Changing user and group ownerships of files and directories**

Linux is a multiuser system, so it has many user accounts. Even if you're the only user on your system, there will be a whole host of system user accounts. These aren't for people. They're just for running specific programs; many servers require a unique username and group name. For example, the FTP server runs under the username `ftp`.

User accounts can belong to one or more groups. Typically, each username has a corresponding private group name. By default, each user belongs to that corresponding private group. However, you can define other groups for the purpose of providing access to specific files and directories based on group membership.

User and group ownerships of files are a way to make sure that only the right people (or the right process) can access the right files and directories. Managing the user and group accounts is a typical job for system administration. It's not hard to do this part of the job, given the tools that come with Linux, as you discover in this chapter.

Adding User Accounts

You get the chance to add user accounts when you boot your system for the first time after installing Linux. Typically (depending on your distribution), the `root` account is the only one that must be created/set up during installation. If you don't add other user accounts when you start the system for the first time, you can add new users later on, using a GUI user account manager or the `useradd` command.



Creating other user accounts besides `root` is always a good idea. Even if you're the only user of the system, logging in as a less privileged user is good practice because that way you can't damage any important system files inadvertently. If necessary, you can type `su` - to log in as `root` and then perform any system administration tasks.

Managing user accounts by using a GUI user manager

Most Linux distributions come with a GUI tool to manage user accounts. You can use that GUI tool to add new user accounts. The tool displays a list of current user accounts and has an Add button for adding new users. For the purposes of illustration, the YaST interface from OpenSUSE is shown in Figure 2-1.

Figure 2-1: In SUSE, select the Security and Users category from the left side of the YaST Control Center, and then click the User and Group Management icon in the right side of the window.

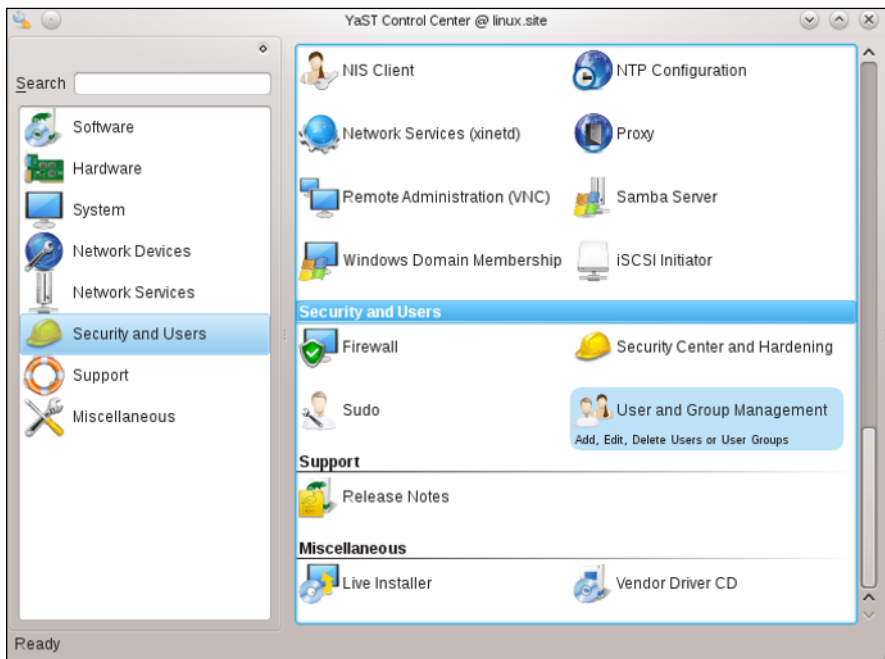

The basic steps, regardless of the specific GUI tool, are as follows:

1. Click the Add User button.

A dialog box prompts you for information about the username and password variables for the new user account, as shown in Figure 2-2.

Figure 2-2:
You can
create the
account
by sup-
plying the
requested
variables.

The screenshot shows a window titled 'YaST2' with a sub-window 'New Local User'. The window has four tabs: 'User Data', 'Details', 'Password Settings', and 'Plug-Ins'. The 'User Data' tab is active. It contains the following fields and options:

- User's Full Name:** A text box containing 'Evan Dulaney'.
- Username:** A text box containing 'evan'.
- Password:** A text box with masked characters (dots).
- Confirm Password:** A text box with masked characters (dots).
- Receive System Mail:** An unchecked checkbox.
- Disable User Login:** An unchecked checkbox.

At the bottom of the window are three buttons: 'Help', 'Cancel', and 'OK'.

2. Enter the requested information.

The GUI tool takes care of adding the new user account.

3. (Optional) Click one of the other tabs for the user (refer to Figure 2-2) to configure additional information.

The Details tab (shown in Figure 2-3) allows you to override the defaults for the home directory, shell, and ID information.

The Password Settings tab (shown in Figure 2-4) allows you to override the defaults for the password configuration. Plug-Ins can be used for a number of parameters, but are often used with *quota configuration* (such as size limits on files and the number of inodes that can be created):

- *Soft limits* warn the user.
- *Hard limits* stop the user.



The tabs — other than User Data — are used to override the system defaults. If you want to change the system defaults, change the variables in the User and Group Administration interface.

Figure 2-3: Use Details to configure settings other than the defined defaults for user accounts.

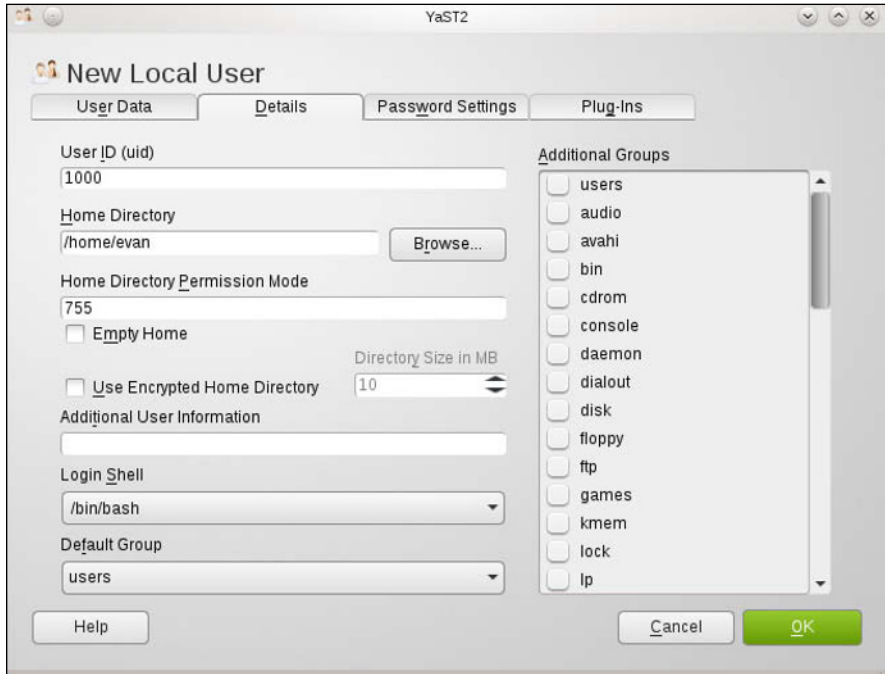
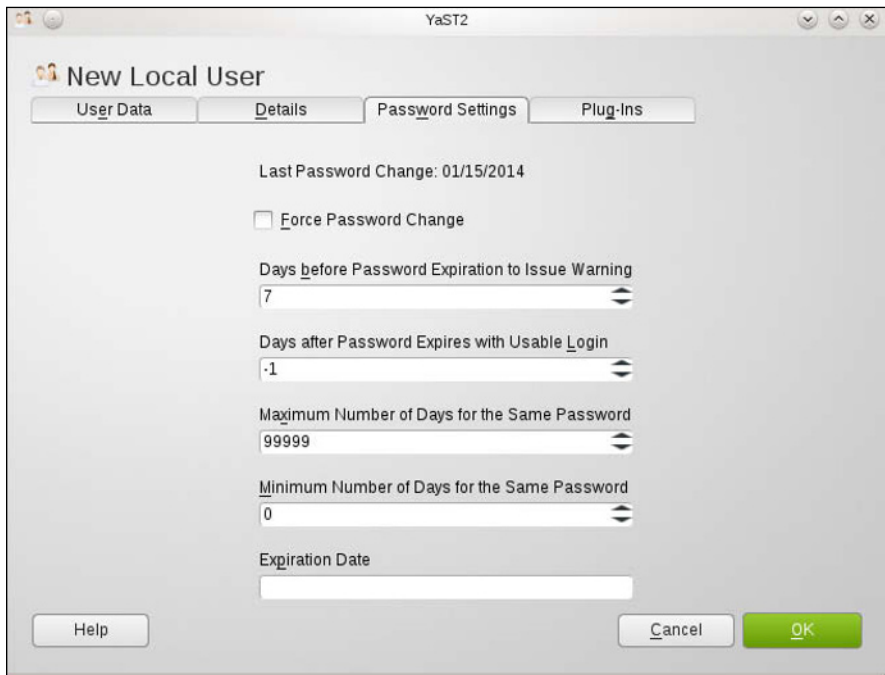

Figure 2-4: Use Password Settings to configure settings other than the defined defaults for new user accounts.



Notice that the tool you use for adding new users is called User and Group Management because there are two types of accounts it can configure: Users and Groups. Selecting Groups instead of Users allows you to add new groups to `/etc/group`, as shown in Figure 2-5.

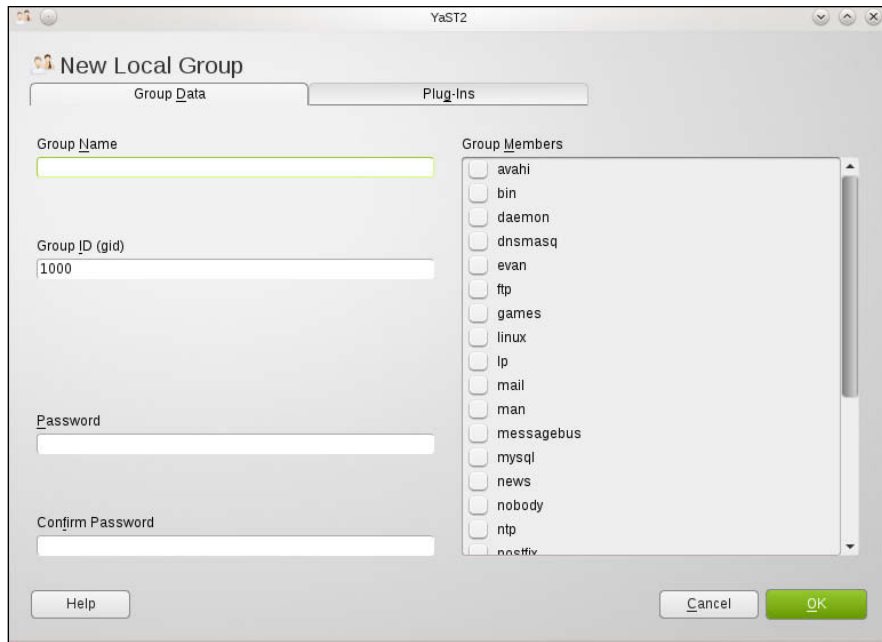

Figure 2-5: Groups can be created and managed similarly to users.

To add a new user account, click the Add button and enter the information requested in the New Local User window. Fill in the requested information (including any add-ins such as for group quotas) and then click the OK button.

Notice that the newly added user account from Figure 2-2 now appears in the list of users in the Group Members pane and can be added — along with others — to the group.

You can add more user or group accounts, if you like. When you finish, click the OK button to create any new accounts you've added; then you exit automatically.

By default, YaST places all local users in a group named `users`. Sometimes you want a user to be in another group as well, so that user can access the files owned by that group. Adding a user to another group is easy. For example, to add the username `kdulaney` to the group called `wheel`, type the following command in a terminal window:

```
usermod -G wheel kdulaney
```



To remove a user account, click the username in the list of user accounts and then click the Remove or the Delete button.

Managing user accounts by using commands

If you're working from a text console, you can create a new user account by using the `useradd` command. Follow these steps to add an account for a new user:

1. Log in as root.

If you're not already logged in as root, type `su -` to become root.

2. Type the following `useradd` command with the `-c` option to create the account:

```
/usr/sbin/useradd -c "Kristin Dulaney" kdulaney
```

3. Set the password by using the `passwd` command, as follows:

```
passwd kdulaney
```

You're prompted for the password twice. If you type a password that someone can easily guess, the `passwd` program will scold you and suggest that you use a more difficult password.



The `useradd` command consults the following configuration files to obtain default information about various parameters for the new user account:

- ◆ `/etc/default/useradd`: Specifies the default shell (`/bin/bash`) and the default home directory location (`/home`).
- ◆ `/etc/login.defs`: Provides system-wide defaults for automatic group and user IDs, as well as password-expiration parameters.
- ◆ `/etc/skel`: Contains the default files that `useradd` creates in the user's home directory.

Examine these files with the `cat` or `more` commands to see what they contain.



You can delete a user account by using the `userdel` command. Simply type `/usr/sbin/userdel username` at the command prompt where *username* is the name of the user you want to remove. To wipe out that user's home directory as well, type `+userdel -r username`.

To modify any information in a user account, use the `usermod` command. For example, for user `kdulaney` to have `root` as the primary group, type the following:

```
usermod -g root kdulaney
```



To find out more about the `useradd`, `userdel`, and `usermod` commands, type **man useradd**, **man userdel**, or **man usermod**, respectively, in a terminal window.

Understanding the */etc/passwd* File

The `/etc/passwd` file is a list of all user accounts. It's a text file and any user can read it — no special privileges needed. Each line in `/etc/passwd` has seven fields, separated by colons (:).

Here's a typical entry from the `/etc/passwd` file:

```
kdulaney:x:1000:1000:Kristin Dulaney,,,,:/home/kdulaney:/bin/bash
```

As the example shows, the format of each line in `/etc/passwd` looks like this:

```
username:password:UID:GID:GECOS:homedir:shell
```

Table 2-1 explains the meaning of the seven fields in each `/etc/passwd` entry.

| <i>This Field</i> | <i>Contains</i> |
|-------------------|---|
| username | An alphanumeric username, usually 8 characters long and unique. (Linux allows usernames to be longer than 8 characters, but some other operating systems do not.) |
| password | When present, a 13-character encrypted password. (An <i>empty field</i> means that no password is required to access the account. An <code>x</code> means the password is stored in the <code>/etc/shadow</code> file, which is more secure.) |
| UID | A unique number that serves as the user identifier. (<code>root</code> has a UID of 0, and usually UIDs from 1 to 100 are reserved for non-human users such as servers; keeping the UID value to less than 32,767 is best.) |
| GID | The default group ID of the group to which the user belongs (GID 0 is for group <code>root</code> , other groups are defined in <code>/etc/group</code> , and users can be, and usually are, in more than one group at a time). |
| GECOS | Optional personal information about the user. (The <code>finger</code> command uses this field; <i>GECOS</i> stands for General Electric Comprehensive Operating System, a long-forgotten operating system that's immortalized by the name of this field in <code>/etc/passwd</code> .) |

(continued)

Table 2-1 (continued)

| <i>This Field</i> | <i>Contains</i> |
|-------------------|---|
| homedir | The name of the user's home directory. |
| shell | The command interpreter (shell), such as <code>bash (/bin/bash)</code> , which executes when this user logs in. |

Managing Groups

A *group* is something to which users belong. A group has a name and an identification number (ID). After a group is defined, users can belong to one or more of these groups.

You can find all the existing groups listed in `/etc/group`. For example, here's the line that defines the group named `wheel`:

```
wheel:x:10:root,kdulaney
```

As this example shows, each line in `/etc/group` has the following format, with four fields separated by colons:

```
groupname:password:GID:membership
```

Table 2-2 explains the meaning of the four fields in a group definition.

Table 2-2 Meaning of Fields in `/etc/group` File

| <i>Field Name</i> | <i>Meaning</i> |
|-------------------|---|
| <i>Groupname</i> | The name of the group (for example, <code>wheel</code>) |
| <i>Password</i> | The group password (an <code>x</code> means that the password is stored in the <code>/etc/shadow</code> file) |
| <i>GID</i> | The numerical group ID (for example, <code>10</code>) |
| <i>Membership</i> | A comma-separated list of usernames that belong to this group (for example, <code>root,kdulaney</code>) |

If you want to create a new group, you can simply use the `groupadd` command. For example, to add a new group called `class` with an automatically selected group ID, type the following command in a terminal window (you have to be logged in as `root`):

```
groupadd class
```

Then you can add users to this group with the `usermod` command. For example, to add the user `kdulaney` to the group named `class`, type the following commands:

```
usermod -G class kdulaney
```

If you want to remove a group, use the `groupdel` command. For example, to remove a group named `class`, type

```
groupdel class
```

Other User and Group Administration Values

One of the easiest ways to administer users and groups is to make certain you have the default values set to what you want them to be.

The concept of *least privilege* should be followed and, as the name implies, the goal of it is to give users the minimal privileges needed to do their jobs and nothing more.

Figure 2-6 shows the values that can be set for global password values. If you check the box `Check New Passwords`, then users will be prevented from using passwords that can be found in a dictionary, that are names, or use common words. The minimum password length can only be set if `Check New Passwords` is enabled; also consider the possible encryption methods seriously:

- ◆ DES is the default encryption method of many distributions, and although it works in almost any environment, it limits passwords to eight characters or fewer.
- ◆ MD5 lets you use longer passwords and is supported by all newer distributions, but can be a problem if you need to interact with older systems.
- ◆ SHA-512 is usually the other choice offered and it a strong hash method that is not compatible with many systems.

The default settings for new users, shown in Figure 2-7, can be set to increase security by choosing a different skeleton, a more secure shell, or a higher `umask` value.

Lastly, the authentication settings (shown in Figure 2-8) allow you to configure the connection settings that will take effect by default.

Figure 2-6: Global password variables can greatly increase system security.

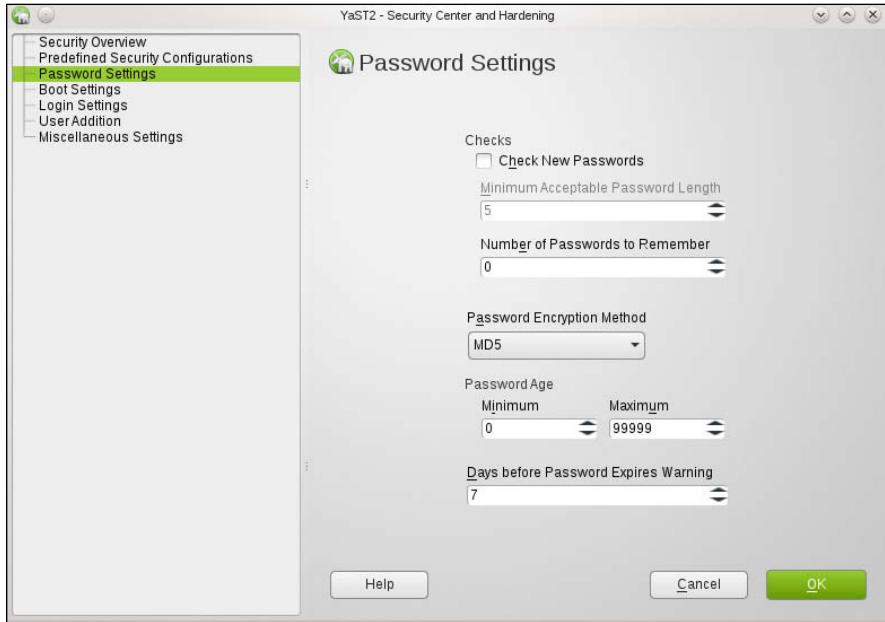
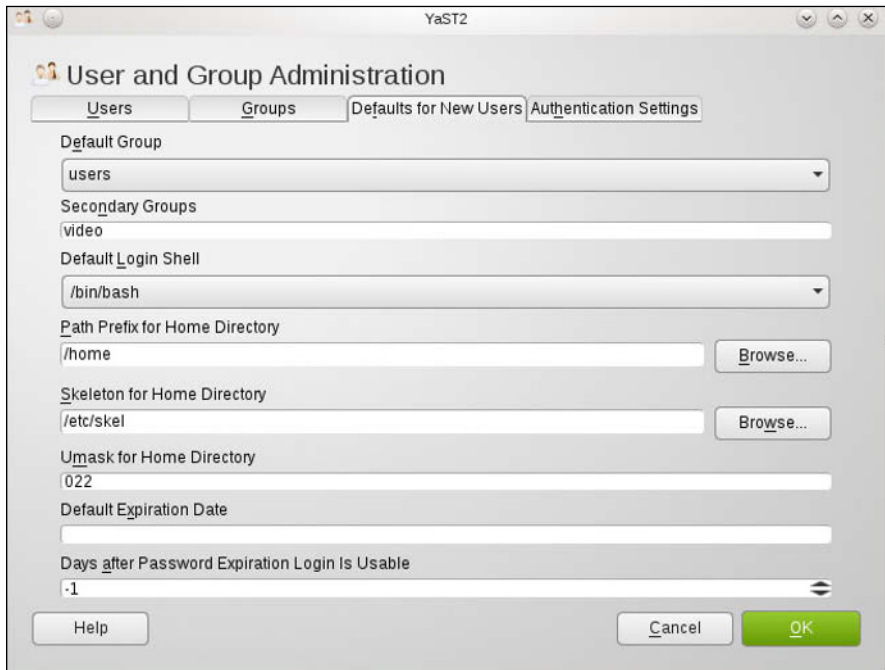

Figure 2-7: Default values for the new users can be changed.



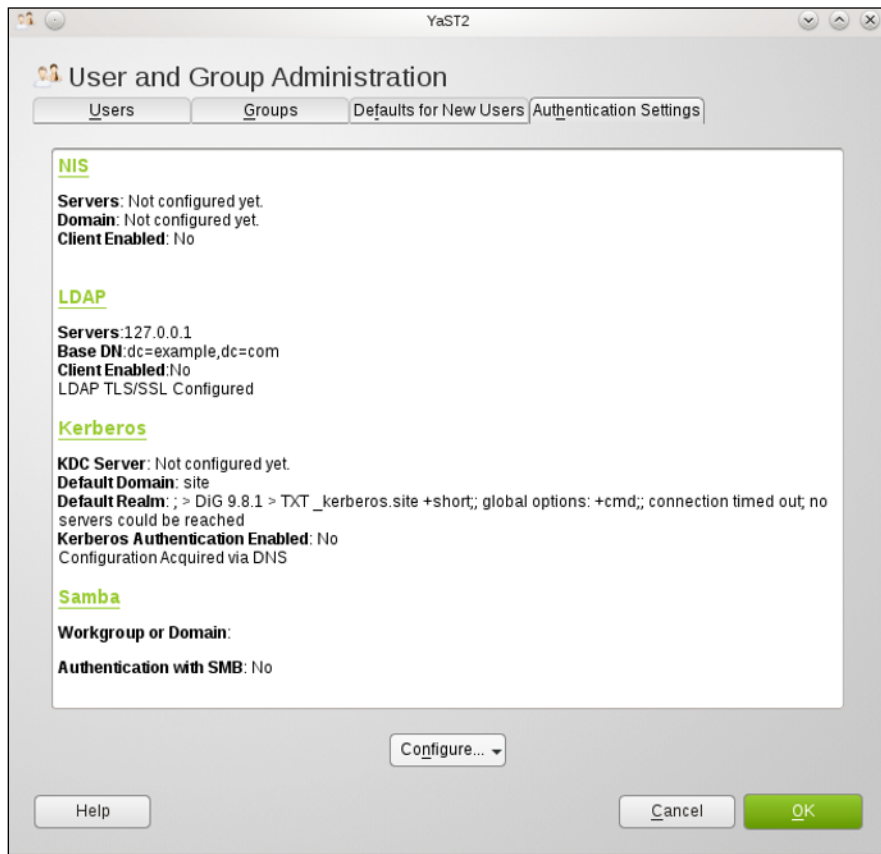

Figure 2-8: Default authentication setting values can be changed.

Exploring the User Environment

When you log in as a user, you get a set of environment variables that control many aspects of what you see and do on your Linux system. If you want to see your current environment, type the following command in a terminal window:

```
env
```

(By the way, the `printenv` command also displays the environment, but `env` is shorter.)

The `env` command prints a long list of lines. The collection of lines is the current environment; each line defines an environment variable. For example, the `env` command displays this typical line:

```
HOSTNAME=localhost.localdomain
```

This line defines the environment variable `HOSTNAME` as `localhost.localdomain`.

An *environment variable* is nothing more than a name associated with a string. For example, the environment variable named `PATH` is typically defined as follows for a normal user:

```
PATH=/usr/local/bin:/bin:/usr/bin:/usr/local/sbin:/usr/  
sbin:/sbin
```

The string to the right of the equal sign (=) is the value of the `PATH` environment variable. By convention, the `PATH` environment variable is a sequence of directory names, each name separated from the others by a colon (:).

Each environment variable has a specific purpose. For example, when the shell has to search for a file, it simply searches the directories listed in the `PATH` environment variable in the order of their appearance. Therefore, if two programs have the same name, the shell executes the one it finds first.

In a fashion similar to the shell's use of the `PATH` environment variable, an editor such as `vi` uses the value of the `TERM` environment variable to figure out how to display the file you edit with `vi`. To see the current setting of `TERM`, type the following command at the shell prompt:

```
echo $TERM
```

If you type this command in a terminal window, the output is as follows:

```
xterm
```

To define an environment variable in `bash`, use the following syntax:

```
export NAME=Value
```

Here `NAME` denotes the name of the environment variable and `Value` is the string representing its value. Therefore you set `TERM` to the value `xterm` by using the following command:

```
export TERM=xterm
```



After you define an environment variable, you can change its value by simply specifying the new value with the syntax `NAME=new-value`. For example, to change the definition of `TERM` to `vt100`, type **`TERM=vt100`** at the shell prompt.

With an environment variable such as `PATH`, typically you want to append a new directory name to the existing definition rather than define the `PATH` from scratch. For example, if you download and install the fictional XYZ 5 Development Kit, you have to add the location of the XYZ binaries to `PATH`. Here's how you accomplish that task:

```
export PATH=$PATH:/usr/xyz/xyz.5.0/bin
```

This command appends the string `/usr/xyz/xyz.5.0/bin` to the current definition of the `PATH` environment variable. The net effect is to add `/usr/xyz/xyz.5.0/bin` to the list of directories in `PATH`.

Note: You also can write this `export` command as follows:

```
export PATH=${PATH}:/usr/xyz/xyz.5.0/bin
```

After you type that command, you can access programs in the `/usr/xyz/xyz.5.0/bin` directory that the interpreter can execute.

`PATH` and `TERM` are only two of a handful of common environment variables. Table 2-3 lists some of the environment variables for a typical Linux user.

| Environment Variable | Contents |
|-----------------------------|--|
| <code>DISPLAY</code> | The name of the display on which the X Window System displays output (typically set to <code>:0.0</code>) |
| <code>HOME</code> | Your home directory |
| <code>HOSTNAME</code> | The host name of your system |
| <code>LOGNAME</code> | Your login name |
| <code>MAIL</code> | The location of your mail directory |
| <code>PATH</code> | The list of directories in which the shell looks for programs |
| <code>SHELL</code> | Your shell (<code>SHELL=/bin/bash</code> for <code>bash</code>) |
| <code>TERM</code> | The type of terminal |

Changing User and Group Ownership of Files

In Linux, each file or directory has two types of owners: a user and a group. In other words, a user and group own each file and directory. The user and group ownerships can control who can access a file or directory.

To view the owner of a file or directory, use the `ls -l` command to see the detailed listing of a directory. For example, here's a typical file's information:

```
-rw-rw-r-- 1 kdulaney kdulaney 40909 Aug 16 20:37
  composer.txt
```

In this example, the first set of characters shows the file's permission setting — who can read, write, or execute the file. The third and fourth fields (in this example, `kdulaney kdulaney`) indicate the user and group owner of the file. Each user has a private group that has the same name as the username. Thus most files appear to show the username twice when you list user and group ownership.

As a system administrator, you may decide to change the group ownership of a file to a common group. For example, suppose you want to change the group ownership of the `composer.txt` file to the `class` group. To do that, log in as `root` and type the following command:

```
chgrp class composer.txt
```

This `chgrp` command changes the group ownership of `composer.txt` to `class`.

You can use the `chown` command to change the user owner. The command has the following format:

```
chown username filename
```

For example, to change the user ownership of a file named `sample.jpg` to `kdulaney`, type

```
chown kdulaney sample.jpg
```

The `chown` command can change both the user and group owner at the same time. For example, to change the user owner to `kdulaney` and the group owner to `class`, type

```
chown kdulaney.class composer.txt
```

In other words, you simply append the group name to the username with a period in between, and then use that as the name of the owner.

Chapter 3: Managing File Systems

In This Chapter

- ✓ Navigating the Linux file system
- ✓ Sharing files with NFS
- ✓ Backing up and restoring files
- ✓ Mounting the NTFS file system
- ✓ Accessing MS-DOS files

A *file system* refers to the organization of files and directories. As a system administrator, you have to perform certain operations to manage file systems on various storage media. For example, you have to know how to *mount* — add a file system on a storage medium by attaching it to the overall Linux file system. You also have to back up important data and restore files from a backup. Other file-system operations include sharing files with the Network File System (NFS) and accessing MS-DOS files. This chapter shows you how to perform all file-system management tasks.

Exploring the Linux File System



The files and directories in your PC store information in an organized manner, just like paper filing systems. When you store information on paper, typically you put several pages in a folder and then store the folder in a file cabinet. If you have many folders, you probably have some sort of filing system. For example, you may label each folder's tab and then arrange them alphabetically in the file cabinet. You might have several file cabinets, each with lots of drawers, which, in turn, contain folders full of pages.

Operating systems, such as Linux, organize information in your computer in a manner similar to your paper filing system. Linux uses a file system to organize all information in your computer. Of course, the storage medium isn't a metal file cabinet and paper. Instead, Linux stores information on devices such as hard drives, USB drives, and DVD drives.

To draw an analogy between your computer's file system and a paper filing system, think of a disk drive as the file cabinet. The drawers in the file cabinet correspond to the directories in the file system. The folders in each

drawer are also directories — because a directory in a computer file system can contain other directories. You can think of files as the pages inside the folder — and that’s where the actual information is stored. Figure 3-1 illustrates the analogy between a file cabinet and the Linux file system.

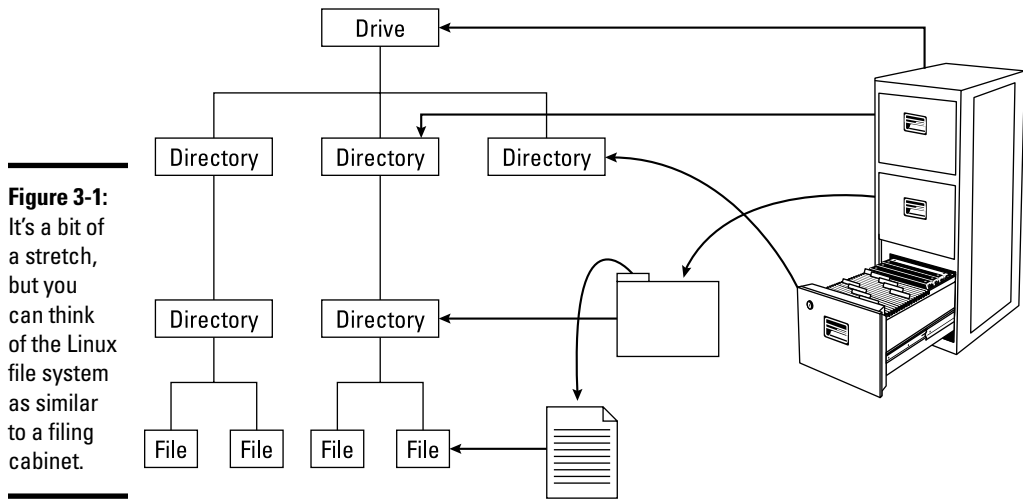

Figure 3-1: It’s a bit of a stretch, but you can think of the Linux file system as similar to a filing cabinet.

The Linux file system has a *hierarchical* structure — directories can contain other directories, which in turn contain individual files.

Everything in your Linux system is organized in files and directories. To access and use documents and programs on your system, you have to be familiar with the file system.

Understanding the file-system hierarchy

The Linux file system is organized like a tree, with a `root` directory from which all other directories branch out. When you write a complete pathname, the `root` directory is represented by a single slash (`/`). Then there’s a hierarchy of files and directories. Parts of the file system can be on different physical drives or in different hard drive partitions.

Linux uses a standard directory hierarchy. Figure 3-2 shows some of the standard parts of the Linux file system. You can create new directories anywhere in this structure.

Figure 3-2:
The Linux
file system
uses a
standard
directory
hierarchy
similar to
this one.

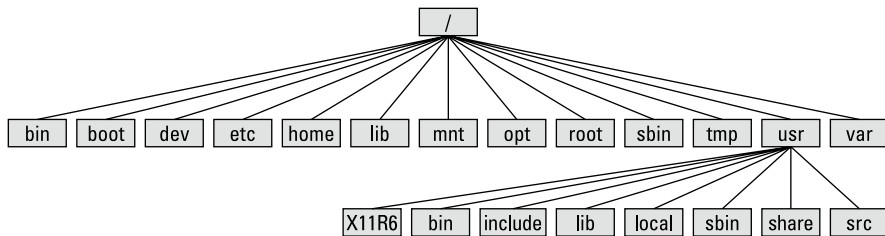

Write the name of any file or directory by concatenating the names of directories that identify where that file or directory is and by using the forward slash (/) as a separator. For example, in Figure 3-2, the `usr` directory at the top level is written as `/usr` because the `root` directory (/) contains `usr`. On the other hand, the `X11R6` directory is inside the `usr` directory, which is inside the `root` directory (/). Therefore the `X11R6` directory is uniquely identified by the name `/usr/X11R6`. This type of full name is a *pathname* because the name identifies the path you take from the `root` directory to reach a file. Thus `/usr/X11R6` is a pathname.



The *Filesystem Hierarchy Standard (FHS)* specifies the organization of files and directories in Unix-like operating systems, such as Linux. FHS defines a standard set of directories and their intended use. The FHS, if faithfully adopted by all Linux distributions, should help improve the interoperability of applications, system administration tools, development tools, and scripts across all Linux distributions. FHS even helps the system documentation (as well as books like this one) because the same description of the file system applies to all Linux distributions. Version 2.3 of FHS was announced on January 29, 2004. FHS 2.3 is part of the Linux Standard Base version 3.x (LSB 3.0), which was released on July 1, 2005. The standard was updated with 3.1 on October 25, 2005, and 3.2 on January 28, 2008. LSB 3.x (see www.linuxbase.org) is a set of binary standards aimed at reducing variations among the Linux distributions and promoting portability of applications. As of this writing, the most current Base is 4.1, which came out in early 2011. To find out more about the Linux Standard Base, check out the home page at

www.linuxfoundation.org/collaborate/workgroups/lsh.

Each of the standard directories in the Linux file system has a specific purpose. Table 3-1, Table 3-2, and Table 3-3 summarize these directories.

Table 3-1 **Standard Directories in Linux File System**

| <i>Directory</i> | <i>Used to Store</i> |
|------------------|--|
| /bin | Executable files for user commands (for use by all users) |
| /boot | Files needed by the boot loader to load the Linux kernel |
| /dev | Device files |
| /etc | Host-specific system configuration files |
| /home | User home directories |
| /lib | Shared libraries and kernel modules |
| /media | Mount point for removable media |
| /mnt | Mount point for a temporarily mounted file system |
| /opt | Add-on application software packages |
| /root | Home directory for the <code>root</code> user |
| /sbin | Utilities for system administration |
| /srv | Data for services (such as web and FTP) offered by this system |
| /tmp | Temporary files |

Table 3-2 **The /usr Directory Hierarchy**

| <i>Directory</i> | <i>Secondary Directory Hierarchy</i> |
|------------------|---|
| /usr/bin | Most user commands |
| /usr/ include | Directory for <i>include files</i> — files that are inserted into source code of applications by using various directives — used in developing Linux applications |
| /usr/lib | Libraries used by software packages and for programming |
| /usr/ libexec | Libraries for applications |
| /usr/ local | Any local software |
| /usr/sbin | Nonessential system administrator utilities |
| /usr/ share | Shared data that doesn't depend on the system architecture (whether the system is an Intel PC or a Sun SPARC workstation) |
| /usr/src | Source code |

Table 3-3 The /var Directory Hierarchy

| <i>Directory</i> | <i>Variable Data</i> |
|------------------|--|
| /var/cache | Cached data for applications |
| /var/lib | Information relating to the current state of applications |
| /var/lock | Lock files to ensure that a resource is used by one application only |
| /var/log | Log files organized into subdirectories |
| /var/mail | User mailbox files |
| /var/opt | Variable data for packages stored in the /opt directory |
| /var/run | Data describing the system since it was booted |
| /var/spool | Data that's waiting for some kind of processing |
| /var/tmp | Temporary files preserved between system reboots |
| /var/yp | Network Information Service (NIS) database files |

Mounting a device on the file system

The storage devices that you use in Linux contain Linux file systems. Each device has its own local file system consisting of a hierarchy of directories. Before you can access the files on a device, you have to attach the device's directory hierarchy to the tree that represents the overall Linux file system.

Mounting is the operation you perform to cause the file system on a physical storage device (a hard drive partition or a CD-ROM) to appear as part of the Linux file system. Figure 3-3 illustrates the concept of mounting.

Figure 3-3 shows each device with a name that begins with /dev. For example, /dev/cdrom is the first DVD/CD-ROM drive. Physical devices are mounted at specific mount points on the Linux file system. For example, the DVD/CD-ROM drive, /dev/cdrom, is mounted on /media/cdrom in the file system. After mounting the CD-ROM in this way, the Fedora directory on a CD-ROM or DVD-ROM appears as /media/cdrom/Fedora in the Linux file system.

LXO-101
Exam

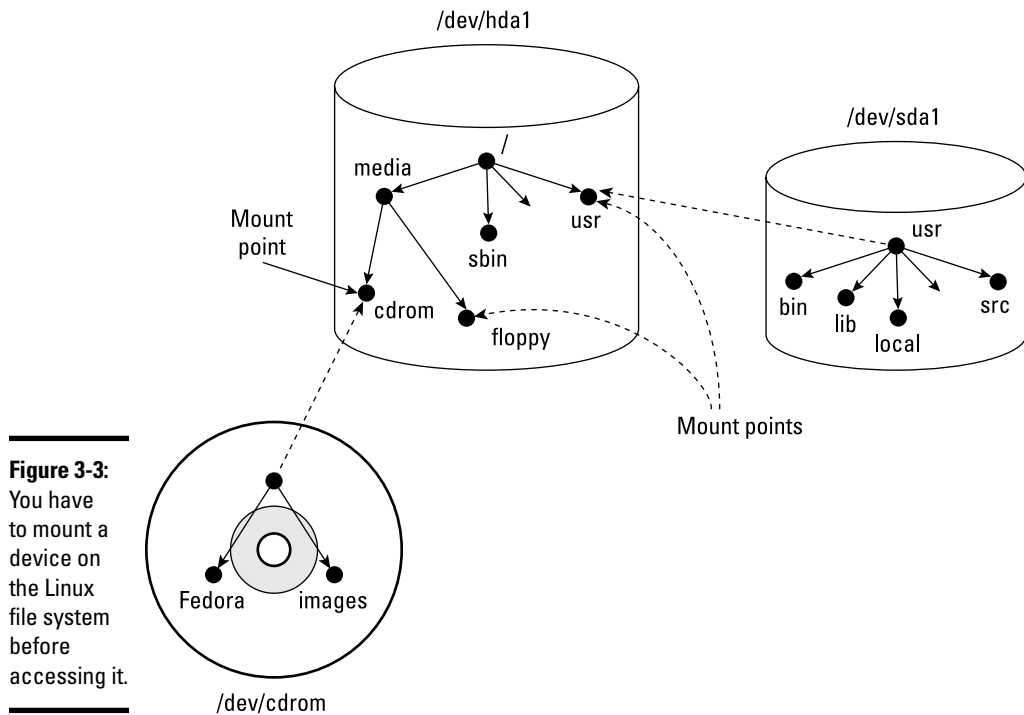
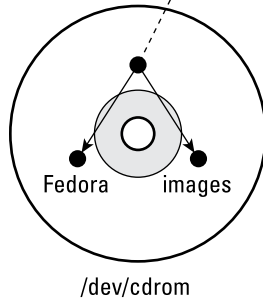

Figure 3-3: You have to mount a device on the Linux file system before accessing it.



You can use the `mount` command to manually mount a device on the Linux file system at a specified directory. That directory is the *mount point*. For example, to mount the DVD/CD-ROM drive at the `/media/cdrom` directory, type the following command (after logging in as `root`):

```
mount /dev/cdrom /media/cdrom
```

The `mount` command reports an error if the DVD/CD-ROM device is mounted already or if no CD or DVD media is in the drive. Otherwise the `mount` operation succeeds, and you can access the contents of the DVD or CD through the `/media/cdrom` directory.



You can use any directory as the mount point. If you mount a device on a nonempty directory, however, you can't access the files in that directory until you unmount the device by using the `umount` command. Therefore always use an empty directory as the mount point.



To unmount a device when you no longer need it, use the `umount` command. For example, for a DVD/CD-ROM device with the device name `/dev/cdrom`, type the following command to unmount the device:

```
umount /dev/cdrom
```

The `mount` command succeeds as long as no one is using the DVD/CD-ROM. If you get an error when trying to unmount the DVD/CD-ROM, check to see if the current working directory is on the DVD or CD. If you're currently working in one of the DVD/CD-ROM's directories, that also qualifies as a use of the DVD/CD-ROM.



LX0-102
Exam

Examining the `etc/fstab` file

The `mount` command has the following general format:

```
mount device-name mount-point
```



However, you can mount by specifying only the CD-ROM device name or the `mount-point` name, provided there's an entry in the `/etc/fstab` file for the CD-ROM mount point. That entry specifies the CD-ROM device name and the file-system type. That's why you can mount the CD-ROM with a shorter mount command.



For example, in Debian, you can mount the CD-ROM by typing one of the following commands:

```
mount /dev/cdrom
mount /media/cdrom
```

The `/etc/fstab` file is a *configuration file* — a text file containing information that the `mount` and `umount` commands use. Each line in the `/etc/fstab` file provides information about a device and its mount point in the Linux file system. Essentially, the `/etc/fstab` file associates various mount points within the file system with specific devices, which enables the `mount` command to work from the command line with only the mount point or the device as argument.



Here's a `/etc/fstab` file from a SUSE system. (The file has a similar format in other Linux distributions.)

```
/dev/hda7 /boot ext3 acl,user_xattr 1 2
/dev/hda6 /data1 auto noauto,user 0 0
/dev/hda9 /data2 auto noauto,user 0 0
/dev/hda10 /data3 auto noauto,user 0 0
/dev/hda5 /data4 auto noauto,user 0 0
/dev/hda2 /windows/C ntfs ro,users,gid=users,umask=0002,nls=utf8 0 0
/dev/hda8 swap swap pri=42 0 0
devpts /dev/pts devpts mode=0620,gid=5 0 0
proc /proc proc defaults 0 0
usbfs /proc/bus/usb usbfs noauto 0 0
sysfs /sys sysfs noauto 0 0
/dev/cdrecorder /media/cdrecorder subfs fs=cdfss,ro,procluid,nosuid,nodev,exec,ioc
harset=utf8 0 0
```

The first field on each line shows a device name, such as a hard drive partition. The second field is the mount point, and the third field indicates the type of file system on the device. You can ignore the last three fields for now.

This `/etc/fstab` file shows that the `/dev/hda8` device functions as a swap device for virtual memory, which is why both the mount point and the file-system type are set to `swap`.



The Linux operating system uses the contents of the `/etc/fstab` file to mount various file systems automatically. During Linux startup, the `init` process executes a shell script that runs the `mount -a` command. That command reads the `/etc/fstab` file and mounts all listed file systems (except those with the `noauto` option). The third field on each line of `/etc/fstab` specifies the type of file system on that device, and the fourth field shows a comma-separated list of options that the `mount` command uses when mounting that device on the file system. Typically, you find the `defaults` option in this field. The `defaults` option implies — among other things — that the device mounts at boot time, that only the `root` user can mount the device, and that the device mounts for both reading and writing. If the options include `noauto`, the device doesn't mount automatically when the system boots.



In Fedora, you often find the `managed` option in the fourth field of `/etc/fstab` entries. The `managed` option indicates that the line was added to the `fstab` file by the HAL (hardware abstraction layer) daemon, which runs the `fstab-sync` command to add entries in the `/etc/fstab` file for each removable drive that it detects. You typically find that the entries for DVD/CD-ROM drive(s) (`/dev/hdc` in most systems) have the `managed` option in the fourth field.

Sharing Files with NFS



Sharing files through the NFS is simple and involves two basic steps:

- ◆ On the NFS server, export one or more directories by listing them in the `/etc/exports` file and by running the `/usr/sbin/exportfs` command. In addition, you must run the NFS server.
- ◆ On each client system, use the `mount` command to mount the directories the server has exported.



How you start the NFS server depends on the Linux distribution. If a GUI `sysadmin` tool is available, you can start the NFS server from the GUI tool. Otherwise, you can type a command in a terminal window to start the NFS server:

- ◆ In Debian, you can type **invoke-rc.d nfs-kernel-server start** and **invoke-rc.d nfs-common start** to start the NFS server.
- ◆ In Fedora, type **service nfs start**.
- ◆ To start the NFS server in SUSE, you can use the YaST Control Center: From the main menu, choose the Kickoff Application Launcher → YaST → System → System Services (run level).
Doing so brings up a screen such as that shown in Figure 3-4.
- ◆ In Xandros, you can start the NFS server from the Xandros Control Center (Main Menu → Control Center) or by typing **invoke-rc.d nfs-user-server start** in a terminal window.

The only problem in using NFS is that each client system must support it. Most PCs don't come with NFS — that means you have to buy NFS software separately if you want to share files by using NFS. If, however, all systems on your LAN run Linux (or other variants of Unix with built-in NFS support), using NFS makes sense.

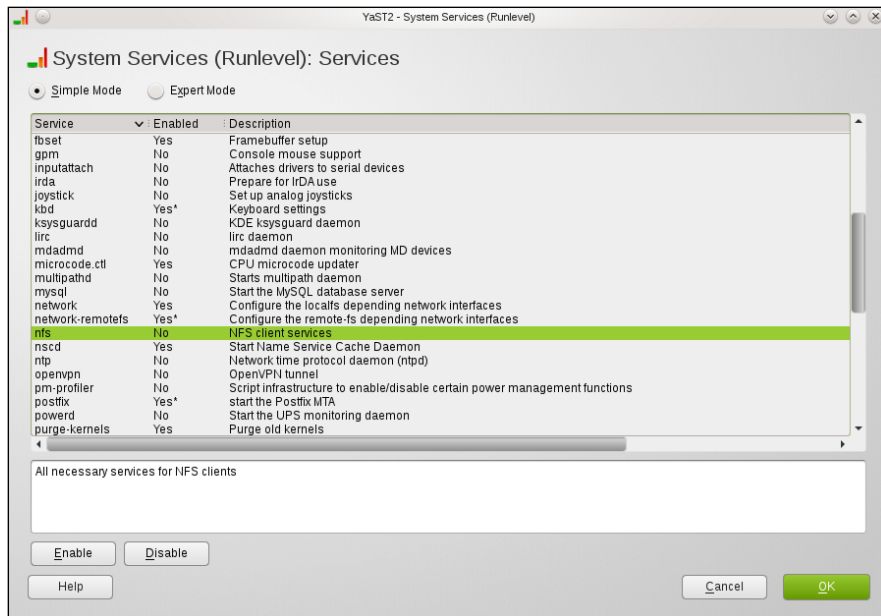

Figure 3-4:
You can
start NFS in
openSUSE
from YaST.



NFS has security vulnerabilities. Therefore don't set up NFS on systems directly connected to the Internet.

The upcoming section walks you through an NFS setup, using an example of two Linux PCs on a LAN.

Exporting a file system with NFS

To export a file system with NFS, start with the server system that *exports* — makes available to the client systems — the contents of a directory. On the server, you must run the NFS service and also designate one or more file systems to be exported to the client systems.

You have to add an appropriate entry to the `/etc/exports` file. For example, suppose you want to export the `/home` directory and you want to enable the hostname `LNBP75` to mount this file system for read and write operations. (You can use a host's IP address in place of the hostname.) You can do so by adding the following entry to the `/etc/exports` file:

```
/home LNBP75(rw)
```

If you use the IP address of a host, the entry might look like this:

```
/home 192.168.1.200(rw)
```

This specifies that `192.168.1.200` is the IP address of the host that's allowed full access to the `/home` directory.

After adding the entry in the `/etc/exports` file, start the NFS server using a method appropriate for your Linux distribution. For example, in Fedora, log in as `root` and type the following command in a terminal window:

```
service nfs start
```

When the NFS service is up, the server side of NFS is ready. Now you can try to mount the exported file system from a client system and access the exported file system.



TIP

If you ever make any changes to the exported file systems listed in the `/etc/exports` file, remember to restart the NFS service. For example, in Fedora, type **`service nfs restart`** in a terminal window. In Xandros, type **`invoke-rc.d nfs-user-server restart`**.

Mounting an NFS file system

To access an exported NFS file system on a client system, you have to mount that file system on a *mount point* — which is, in practical terms, nothing more than a local directory. For example, suppose you want to access the `/home/public` directory exported from the server named `LNBP200` at the local directory `/mnt/lnbp200` on the client system. To do so, follow these steps:



LXO-102
Exam

1. Log in as `root` and create the directory with the following command:

```
mkdir /mnt/lntp200
```

2. Type the following command to perform the `mount` operation:

```
mount lntp200:/home/public /mnt/lntp200
```

If you know only the IP address of the server, replace the hostname (in this case, `lntp200`) with the IP address.

3. Change the directory to `/mnt/lntp200` with the command `cd /mnt/lntp200`.

Now you can view and access exported files from this directory.



To confirm that the NFS file system is indeed mounted, log in as `root` on the client system and type `mount` in a terminal window. You see a line similar to the following about the NFS file system:

```
lntp200:/home/public on /mnt/lntp200 type nfs (rw,addr=192.168.1.200)
```

Backing Up and Restoring Files



Backing up and restoring files is a crucial system administration task. If something happens to your system's hard drive, you have to rely on the backups to recover important files. The following discussion presents some backup strategies, describes several backup media, and explains how to back up and restore files by using the tape archiver (`tar`) program that comes with Linux. Also, you find out how to perform incremental and automatic backups on tapes.



If you have a CD burner, you can back up files also by recording them on a CD-R. Consult Book II, Chapter 5, for information on what application you can use to burn a data CD.

Selecting a backup strategy and media

Your Linux system's hard drive contains everything you need to keep the system running — as well as other files (such as documents and databases) that keep your business running. You have to back up these files so you can recover quickly and bring the system back to normal in case the hard drive crashes. Typically, you have to follow a strict regimen of regular backups because you can never tell when the hard drive may fail or the file system may get corrupted. To implement such a regimen, first decide which files you want to back up, how often, and what backup storage media to use. This process is what is meant by selecting a backup strategy and backup media.

Your choice of backup strategy and backup media depends on your assessment of the risk of business disruption due to hard drive failure. Depending on how you use your Linux system, a disk failure may or may not have much effect on you.

For example, if you use your Linux system as a learning tool (to find out more about Linux or programming), all you may need are backup copies of some system files required to configure Linux. In this case, your backup strategy can be to save important system configuration files on your preferred storage media every time you change any system configuration.

On the other hand, if you use your Linux system as an office server that provides shared file storage for many users, the risk of business disruption due to disk failure is much higher. In this case, you have to back up all the files every week and back up any new or changed files every day. You can perform these backups in an automated manner (with the job-scheduling features described in Chapter 1 of this minibook). Also, you probably need a backup storage medium that can store many gigabytes of data. In other words, for high-risk situations, your backup strategy has to be more elaborate and requires additional equipment (such as a high-capacity external hard drive).

Your choice of backup media depends on the amount of data you have to back up. For a small amount of data (such as system configuration files), you can use USB flash drives as backup media. If your PC has an old Zip drive, you can use Zip disks as backup media; these are good for backing up a single-user directory. To back up entire servers, use an external hard drive (which could be attached to the computer or the network) or other storage device.

When backing up files to these media, you have to refer to the backup device by name. You will find these devices under the `/dev` directory.

Commercial backup utilities for Linux

The next section explains how to back up and restore files using the tape archiver (`tar`) program that comes with Linux. Although you can manage backups with `tar`, a number of commercial backup utilities come with graphical user interfaces and other features to simplify backups. Here are some well-known commercial backup utilities for Linux:

- ◆ **BRU:** A backup and restore utility from the TOLIS Group, Inc. (www.tolisgroup.com)
- ◆ **LONE-TAR:** Tape backup software package from Lone Star Software Corp. (www.cactus.com)

- ◆ **Arkeia:** Backup and recovery software for heterogeneous networks from Arkeia (www.arkeia.com)
- ◆ **CA ARCserve Backup for Linux:** Data-protection technology for Linux systems from Computer Associates (<http://www.arcserve.com>)

Using the tape archiver — tar

You can use the `tar` command to archive files to a device, such as a hard drive or tape. The `tar` program creates an archive file that can contain other directories and files and (optionally) compress the archive for efficient storage. The archive is then written to a specified device or another file. Many software packages are distributed in the form of a compressed `tar` file.

The command syntax of the `tar` program is as follows:

```
tar options destination source
```

Here *options* are usually specified by a sequence of single letters, with each letter specifying what `tar` does. The *destination* is the device name of the backup device. And *source* is a list of file or directory names denoting the files to back up.

Backing up and restoring a single-volume archive

Suppose you want to back up the contents of the `/etc/X11` directory on a hard drive. Log in as `root`, and type the following command, where `xxx` represents your drive:

```
tar zcvf /dev/xxx /etc/X11
```

The `tar` program displays a list of filenames as each file is copied to the compressed `tar` archive. In this case, the options are `zcvf`, the destination is `/dev/xxx` (the drive), and the source is the `/etc/X11` directory (which implies all its subdirectories and their contents). You can use a similar `tar` command to back up files to a tape — simply replace the hard drive location with that of the tape device — such as `/dev/st0` for a SCSI tape drive.

Table 3-4 defines a few common `tar` options.

| Table 3-4 Common tar Options | |
|------------------------------|---|
| Option | Does the Following |
| c | Creates a new archive. |
| f | Specifies the name of the archive file or device on the next field in the command line. |

(continued)

Table 3-4 (continued)

| <i>Option</i> | <i>Does the Following</i> |
|---------------|---|
| M | Specifies a multivolume archive. (The next section describes multivolume archives.) |
| t | Lists the contents of the archive. |
| v | Displays verbose messages. |
| x | Extracts files from the archive. |
| z | Compresses the tar archive using gzip. |

To view the contents of the tar archive you create on the drive, type the following command (replacing xxx with the drive device):

```
tar ztf /dev/xxx
```

You see a list of filenames (each begins with /etc/X11) indicating what's in the backup. In this tar command, the t option lists the contents of the tar archive.

To extract the files from a tar backup, follow these steps while logged in as root:

1. Change the directory to /tmp by typing this command:

```
cd /tmp
```

This step is where you can practice extracting the files from the tar backup. For a real backup, change the directory to an appropriate location (typically, you type cd /).

2. Type the following command:

```
tar zxvf /dev/xxx
```

This tar command uses the x option to extract the files from the archive stored on the device (replace xxx with the drive).

Now if you check the contents of the /tmp directory, you notice that the tar command creates an etc/X11 directory tree in /tmp and restores all the files from the tar archive into that directory. The tar command strips the leading / from the filenames in the archive and restores the files in the current directory. If you want to restore the /etc/X11 directory from the archive, use this command (substituting the device name for xxx):

```
tar zxvf /dev/xxx -C /
```

The `-C` does a `cd` to the directory specified (in this case, the `root` directory of `/`) before doing the `tar`; the `/` at the end of the command denotes the directory where you want to restore the backup files.

You can use the `tar` command to create, view, and restore an archive. You can store the archive in a file or in any device you specify with a device name.

Backing up and restoring a multivolume archive

Sometimes the capacity of a single storage medium is less than the total storage space needed to store the archive. In this case, you can use the `M` option for a multivolume archive — meaning the archive can span multiple tapes or even floppies (if you happen to be using an older machine that still has them). Note, however, that you can't create a compressed, multivolume archive. That means you have to drop the `z` option.

Note: The `M` tells `tar` to create a multivolume archive. The `tar` command prompts you for a second media when the first one is filled. Take out the first media, and insert another when you see the following prompt:

```
Prepare volume #2 and hit return:
```

When you press `Enter`, the `tar` program continues with the second media. For larger archives, the `tar` program continues to prompt for new media as needed.

To restore from this multivolume archive, type `cd /tmp` to change the directory to `/tmp`. (I use the `/tmp` directory for illustrative purposes, but you have to use a real directory when you restore files from archive.) Then type (replacing `xxx` with the device you are using)

```
tar xvfM /dev/xxx
```

The `tar` program prompts you to feed the media as necessary.



Use the `du -s` command to determine the amount of storage you need for archiving a directory. For example, type `du -s /etc` to see the total size of the `/etc` directory in kilobytes. Here's a typical output of that command:

```
35724 /etc
```

The resulting output shows that the `/etc` directory requires at least 35,724 kilobytes of storage space to back up.

Backing up on tapes

Although backing up on tapes is as simple as using the right device name in the `tar` command, you do have to know some nuances of the tape device to use it well. When you use `tar` to back up to the device named `/dev/st0` (the first SCSI tape drive), the tape device automatically rewinds the tape after the `tar` program finishes copying the archive to the tape. The `/dev/st0` device is called a *rewinding tape device* because it rewinds tapes by default.

If your tape can hold several gigabytes of data, you may want to write several `tar` archives — one after another — to the same tape (otherwise much of the tape may be left empty). If you plan to do so, your tape device can't rewind the tape after the `tar` program finishes. To help you with scenarios like this one, several Linux tape devices are nonrewinding. The nonrewinding SCSI tape device is called `/dev/nst0`. Use this device name if you want to write one archive after another on a tape.



After each archive, the nonrewinding tape device writes an end-of-file (EOF) marker to separate one archive from the next. Use the `mt` command to control the tape — you can move from one marker to the next or rewind the tape. For example, after you finish writing several archives to a tape using the `/dev/nst0` device name, you can force the tape to rewind with the following command:

```
mt -f /dev/nst0 rewind
```

After rewinding the tape, you can use the following command to extract files from the first archive to the current disk directory:

```
tar xvf /dev/nst0
```

After that, you must move past the EOF marker to the next archive. To do so, use the following `mt` command:

```
mt -f /dev/nst0 fsf 1
```

This positions the tape at the beginning of the next archive. Now use the `tar xvf` command again to read this archive.



If you save multiple archives on a tape, you have to keep track of the archives yourself. The order of the archives can be hard to remember, so you may be better off simply saving one archive per tape.

Performing incremental backups

Suppose you use `tar` to back up your system's hard drive on a tape. Because such a full backup can take quite some time, you don't want to repeat this task every night. (Besides, only a small number of files may have changed

during the day.) To locate the files that need backing up, you can use the `find` command to list all files that have changed in the past 24 hours:

```
find / -mtime -1 -type f -print
```

This command prints a list of files that have changed within the last day. The `-mtime -1` option means you want the files that were last modified less than one day ago. You can now combine this `find` command with the `tar` command to back up only those files that have changed within the last day:

```
tar cvf /dev/st0 'find / -mtime -1 -type f -print'
```

When you place a command between single back quotes, the shell executes that command and places the output at that point in the command line. The result is that the `tar` program saves only the changed files in the archive. This process gives you an incremental backup of only the files that have changed since the previous day.

Performing automated backups

Chapter 1 of this minibook shows how to use `crontab` to set up recurring jobs (called *cron jobs*). The Linux system performs these tasks at regular intervals. Backing up your system is a good use of the `crontab` facility. Suppose your backup strategy is as follows:

- ◆ Every Sunday at 1:15 a.m., your system backs up the entire hard drive on the tape.
- ◆ Monday through Saturday, your system performs an incremental backup at 3:10 a.m. by saving only those files that have changed during the past 24 hours.

To set up this automated backup schedule, log in as `root` and type the following lines in a file named `backups` (this example assumes that you are using a SCSI tape drive):

```
15 1 * * 0 tar zcvf /dev/st0 /  
10 3 * * 1-6 tar zcvf /dev/st0 'find / -mtime -1 -type f -print'
```

Next, submit this job schedule by using the following `crontab` command:

```
crontab backups
```

Now you're set for an automated backup. All you need to do is to place a new tape in the tape drive every day. Remember also to give each tape an appropriate label.

Accessing a DOS or Windows File System

If you're using a legacy machine that you just don't want to throw out and have a really old version of Microsoft Windows installed on your hard drive, you've probably already mounted the DOS or Windows partition under Linux. If not, you can easily mount DOS or Windows partitions in Linux. Mounting makes the DOS or Windows directory hierarchy appear as part of the Linux file system.

Mounting a DOS or Windows disk partition

LX0-101
Exam

To mount a DOS or Windows hard drive partition or storage device in Linux, use the `mount` command but include the option `-t vfat` to indicate the file-system type as DOS. For example, if your DOS partition happens to be the first partition on your IDE (Integrated Drive Electronics) drive and you want to mount it on `/dosc`, use the following `mount` command:

```
mount -t vfat /dev/hda1 /dosc
```

The `-t vfat` part of the `mount` command specifies that the device you mount — `/dev/hda1` — has an MS-DOS file system. Figure 3-5 illustrates the effect of this `mount` command.

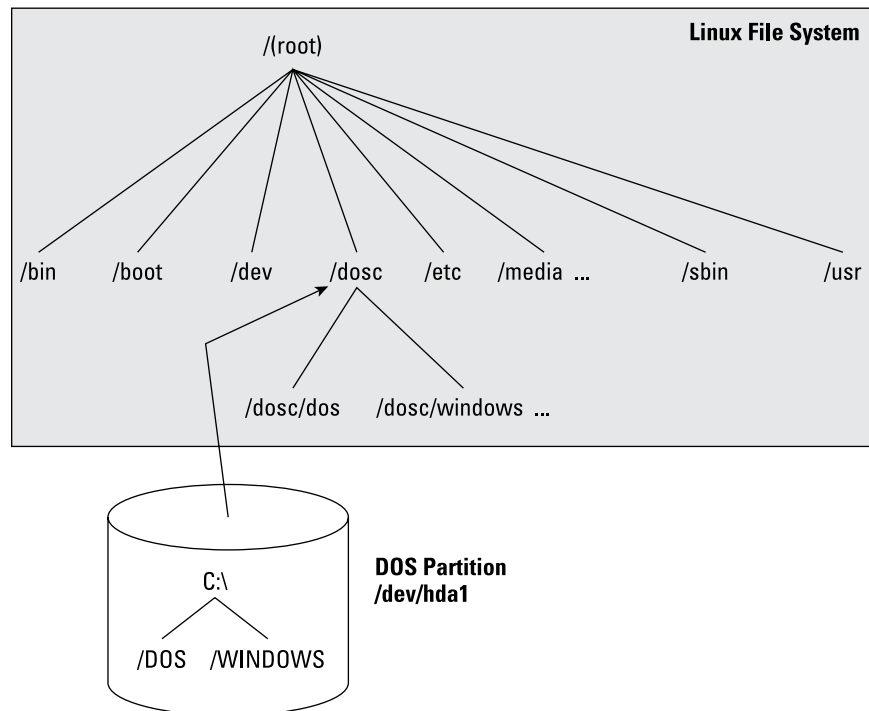

Figure 3-5: Here's how you mount a DOS partition on the `/dosc` directory.

Figure 3-5 shows how directories in your DOS partition map to the Linux file system. What was the `C:\DOS` directory under DOS becomes `/doscdos` under Linux. Similarly, `C:\WINDOWS` now is `/doscd/windows`. You probably can see the pattern. To convert a DOS filename to Linux (when you mount the DOS partition on `/doscd`), perform the following steps:

1. **Change the DOS names to lowercase.**
2. **Change `C:\` to `/doscd/`.**
3. **Change all backslashes (`\`) to slashes (`/`).**

Mounting those ancient DOS floppy disks

Just as you mount a DOS hard drive partition on the Linux file system, you can also mount a DOS floppy disk on a legacy machine. You must log in as `root` to mount a floppy, but you can set up your system so that any user can mount a DOS floppy disk. You also have to know the device name for the floppy drive. By default, Linux defines the following two generic floppy device names:

- ◆ `/dev/fd0` is the A drive (the first floppy drive)
- ◆ `/dev/fd1` is the B drive (the second floppy drive, if you have one)

You can use any empty directory in the file system as the mount point, but the Linux system comes with a directory, `/media/floppy`, specifically for mounting a floppy disk.

To mount a DOS floppy disk on the `/media/floppy` directory, put the floppy in the drive and type the following command:

```
mount -t vfat /dev/fd0 /media/floppy
```

After you mount the floppy, you can copy files to and from the floppy by using the Linux copy command (`cp`). To copy the file `gnome1.pcx` from the current directory to the floppy, type the following:

```
cp gnome1.pcx /media/floppy
```

Similarly, to see the contents of the floppy disk, type the following:

```
ls /media/floppy
```

If you want to remove the floppy disk from the drive, first unmount the floppy drive. *Unmounting* removes the association between the floppy disk's file system and the mount point on the Linux file system. Use the `umount` command to unmount the floppy disk like this:

```
umount /dev/fd0
```



You can set up your Linux system so that any user can mount a DOS floppy. To enable any user to mount a DOS floppy in the A drive on the `/a` directory, for example, perform the following steps:

1. **Log in as `root`.**
2. **Create the `/a` directory (the mount point) by typing the following command in a terminal window:**

```
mkdir /a
```

3. **Edit the `/etc/fstab` file in a text editor (such as `vi` or `emacs`) by inserting the following line, and then save the file and quit the editor:**

```
/dev/fd0 /a vfat noauto,user 0 0
```

The first field in that line is the device name of the floppy drive (`/dev/fd0`); the second field is the mount directory (`/a`); the third field shows the type of file system (`vfat`). The user option (which appears next to `noauto`) enables all users to mount DOS floppy disks.

4. **Log out and then log back in as a normal user.**
5. **To confirm that you can mount a DOS floppy as a normal user and not just as `root`, insert a DOS floppy in the A drive and type the following command:**

```
mount /a
```

The `mount` operation succeeds, and you see a listing of the DOS floppy when you type the command `ls /a`.

6. **To unmount the DOS floppy, type `umount /a`.**

Mounting an NTFS partition

Nowadays, most PCs come with Windows 7 or Windows 8 pre-installed on the hard drive. Both of these versions of Windows, as well as Windows XP, typically use the NT File System (NTFS). Linux supports read-only access to NTFS partitions, and many distributions come with the `ntfs.ko` kernel module, which is needed to access an NTFS partition.

If you've installed Linux on a Windows system and want to access files on the NTFS partition but your distribution doesn't include the `ntfs.ko` module, you can build the kernel after enabling an NTFS module during the kernel configuration step.

After rebuilding and booting from the new kernel, log in as `root` and type the following command to create a mount point for the NTFS partition. (In this case, I'm creating a mount point in the `/mnt` directory.)

```
mkdir /mnt/windir
```



Now you can mount the NTFS partition with the following command:

```
mount /dev/hda2 /mnt/windir -t ntfs -r -o umask=0222
```



If necessary, replace `/dev/hda2` with the device name for the NTFS partition on your system. On most PCs that come with Windows pre-installed, the NTFS partition is the second one (`/dev/hda2`) — the first partition (`/dev/hda1`) is usually a hidden partition used to hold files used for the Windows installation.

Chapter 4: Working with Samba and NFS

In This Chapter

- ✓ **Sharing files with Network File System**
- ✓ **Installing and configuring Samba**
- ✓ **Setting up a Windows server using Samba**

If your local area network is like many others, it needs the capability to share files between systems that run Linux and other systems that don't. Thus, Linux includes two prominent file-sharing services:

- ◆ **Network File System (NFS):** For sharing files with other Unix systems (or PCs with NFS client software)
- ◆ **Samba:** For file sharing and print sharing with Windows systems

This chapter describes how to share files using both NFS and Samba.

Sharing Files with NFS

Sharing files through NFS is simple and involves two basic steps:

- ◆ On the Linux system that runs the NFS server, you export (share) one or more directories by listing them in the `/etc/exports` file and by running the `exportfs` command. In addition, you must start the NFS server.
- ◆ On each client system, you use the `mount` command to mount the directories that your server has exported.

The only problem in using NFS is that each client system must support it. Microsoft Windows doesn't come with NFS, so you have to buy NFS software separately if you want to share files by using NFS. However, using NFS if all systems on your LAN run Linux (or other variants of Unix with built-in NFS support) makes sense.



NFS has security vulnerabilities. Therefore you should not set up NFS on systems directly connected to the Internet without using the `RPCSEC_GSS` security that comes with NFS version 4 (NFSv4).



The Linux 2.6 kernel includes support for NFSv4, which is built on earlier versions of NFS. But unlike earlier versions, NFSv4 has stronger security and was designed to operate in an Internet environment. (RFC 3510 describes NFSv4; see www.ietf.org/rfc/rfc3530.txt.) NFSv4 uses the RPCSEC_GSS (GSS stands for Generic Security Services) protocol for security. You can continue to use the older user ID- and group ID-based authentication with NFSv4, but if you want to use RPCSEC_GSS you have to run three additional services: `rpcsvcgassd` on the server, `rpsgssd` on the client, and `rpcidmapd` on both the client and the server. For more information about NFSv4 implementation in Linux, visit www.citi.umich.edu/projects/nfsv4/linux.

The next few sections walk you through NFS setup, using an example of two Linux PCs on a LAN.

Exporting a file system with NFS

Start with the server system that *exports* — makes available to the client systems — the contents of a directory. On the server, you must run the NFS service and also designate one or more file systems to export.

To export a file system, you have to add an appropriate entry to the `/etc/exports` file. For example, suppose that you want to export the `/home` directory and you want to enable the host named `LNBPF75` to mount this file system for read and write operations. You can do so by adding the following entry to the `/etc/exports` file:

```
/home LNBPF75(rw,sync)
```

If you want to give access to all hosts on a LAN such as `192.168.0.0`, you could change this line to

```
/home 192.168.0.0/24(rw,sync)
```

Every line in the `/etc/exports` file has this general format:

```
directory host1(options) host2(options) . . .
```

The first field is the directory being shared via NFS, followed by one or more fields that specify which hosts can mount that directory remotely and a number of options in parentheses. You can specify the hosts with names or IP addresses, including ranges of addresses.

The options in parentheses denote the kind of access each host is granted and how user and group IDs from the server are mapped to ID the client. (For example, if a file is owned by `root` on the server, what owner is that on the client?) Within the parentheses, commas separate the options. For example, if a host is allowed both read and write access — and all IDs are to be

mapped to the anonymous user (by default, the anonymous user is named `nobody`) — the options look like this:

```
(rw,all_squash)
```

Table 4-1 shows the options you can use in the `/etc/exports` file. You find two types of options: general options and user ID mapping options.

| Table 4-1 Options in /etc/exports | |
|--|--|
| <i>Option</i> | <i>Description</i> |
| General Options | |
| <code>secure</code> | Allows connections only from ports 1024 or lower (default) |
| <code>insecure</code> | Allows connections from ports 1024 or higher |
| <code>ro</code> | Allows read-only access (default) |
| <code>rw</code> | Allows both read and write access |
| <code>sync</code> | Performs write operations (writing information to the disk) when requested (by default) |
| <code>async</code> | Performs write operations when the server is ready |
| <code>no_wdelay</code> | Performs write operations immediately |
| <code>wdelay</code> | Waits a bit to see whether related write requests arrive and then performs them together (by default) |
| <code>hide</code> | Hides an exported directory that's a subdirectory of another exported directory (by default) |
| <code>no_hide</code> | Causes a directory to not be hidden (opposite of <code>hide</code>) |
| <code>subtree_check</code> | Performs subtree checking, which involves checking parent directories of an exported subdirectory whenever a file is accessed (by default) |
| <code>no_subtree_check</code> | Turns off subtree checking (opposite of <code>subtree_check</code>) |
| <code>insecure_locks</code> | Allows insecure file locking |
| User ID Mapping Options | |
| <code>all_squash</code> | Maps all user IDs and group IDs to the anonymous user on the client |
| <code>no_all_squash</code> | Maps remote user and group IDs to similar IDs on the client (by default) |
| <code>root_squash</code> | Maps remote <code>root</code> user to the anonymous user on the client (by default) |

(continued)

Table 4-1 (continued)

| <i>Option</i> | <i>Description</i> |
|-----------------------------|---|
| <code>no_root_squash</code> | Maps remote <code>root</code> user to the local <code>root</code> user |
| <code>anonuid=UID</code> | Sets the user ID of anonymous user to be used for the <code>all_squash</code> and <code>root_squash</code> options |
| <code>anongid=GID</code> | Sets the group ID of anonymous user to be used for the <code>all_squash</code> and <code>root_squash</code> options |

After adding the entry in the `/etc/exports` file, manually export the file system by typing the following command in a terminal window:

```
exportfs -a
```

This command exports all file systems defined in the `/etc/exports` file.

Now you can start the NFS server processes.



In Debian, start the NFS server by logging in as `root` and typing `/etc/init.d/nfs-kernel-server start` in a terminal window. In Fedora, type `/etc/init.d/nfs start`. In SUSE, type `/etc/init.d/nfsserver start`. If you want the NFS server to start when the system boots, type `update-rc.d nfs-kernel-server defaults` in Debian. In Fedora, type `chkconfig -level 35 nfs on`. In SUSE, type `chkconfig -level 35 nfsserver on`. In Xandros, type `update-rc.d nfs-user-server defaults`.

When the NFS service is up, the server side of NFS is ready. Now you can try to mount the exported file system from a client system and then access the exported file system as needed.



If you ever make any changes to the exported file systems listed in the `/etc/exports` file, remember to restart the NFS service. To restart a service, invoke the script in the `/etc/init.d` directory with `restart` as the argument (instead of the `start` argument that you use to start the service).

Mounting an NFS file system

To access an exported NFS file system on a client system, you have to mount that file system on a mount point. The *mount point* is nothing more than a local directory. For example, suppose that you want to access the `/home` directory exported from the server named `LNB200` at the local directory `/mnt/lntp200` on the client system. To do so, follow these steps:

1. Log in as `root` and create the directory with this command:

```
mkdir /mnt/lntp200
```

2. Type the following command to mount the directory from the remote system (LNBP200) on the local directory /mnt/lnbp200:

```
mount lnbp200:/home /mnt/lnbp200
```

After completing these steps, you can then view and access exported files from the local directory /mnt/lnbp200.

To confirm that the NFS file system is indeed mounted, log in as `root` on the client system and type **mount** in a terminal window. You see a line similar to the following about the NFS file system:

```
lnbp200:/home/public on /mnt/lnbp200 type nfs (rw,addr=192.168.0.4)
```



NFS supports two types of mount operations — hard and soft. By default, a mount is hard, which means that if the NFS server does not respond, the client keeps trying to access the server indefinitely until the server responds. You can soft mount an NFS volume by adding the `-o soft` option to the `mount` command. For a soft mount, the client returns an error if the NFS server fails to respond.

Setting Up a Windows Server Using Samba

If you rely on Windows for file sharing and print sharing, you probably use Windows in your servers and clients. If so, you can still move to a Linux PC as your server without losing Windows file-sharing and print-sharing capabilities; you can set up Linux as a Windows server. When you install Linux from this book's companion DVD-ROM, you also get a chance to install the Samba software package, which performs that setup. All you have to do is select the Windows File Server package group during installation.



After you install and configure Samba on your Linux PC, your client PCs — even if they're running an old Windows operating system or one of the more recent Windows versions — can access shared disks and printers on the Linux PC. To do so, they use the Common Internet File System (CIFS) protocol, the underlying protocol in Windows file and print sharing.

With the Samba package installed, you can make your Linux PC a Windows client, which means that the Linux PC can access the disks and printers that a Windows server manages. At the same time, your Linux PC can be a client to other Windows systems on the network.

The Samba software package has these major components:

- ◆ `/etc/samba/smb.conf`: The Samba configuration file that the SMB server uses.
- ◆ `/etc/samba/smbusers`: A Samba configuration file that shows the Samba usernames corresponding to usernames on the local Linux PC.

- ◆ `nmbd`: The NetBIOS name server, which clients use to look up servers. (NetBIOS stands for *Network Basic Input/Output System* — an interface that applications use to communicate with network transports, such as TCP/IP.)
- ◆ `nmblookup`: A command that returns the IP address of a Windows PC identified by its NetBIOS name.
- ◆ `smbadduser`: A program that adds users to the SMB (Server Message Block) password file.
- ◆ `smbcacls`: A program that manipulates Windows NT access control lists (ACLs) on shared files.
- ◆ `smbclient`: The Windows client, which runs on Linux and allows Linux to access the files and printer on any Windows server.
- ◆ `smbcontrol`: A program that sends messages to the `smbd`, `nmbd`, or `winbindd` processes.
- ◆ `smbd`: The SMB server, which accepts connections from Windows clients and provides file-sharing and print-sharing services.
- ◆ `smbmount`: A program that mounts a Samba share directory on a Linux PC.
- ◆ `smbpasswd`: A program that changes the password for an SMB user.
- ◆ `smbprint`: A script that enables printing on a printer on an SMB server.
- ◆ `smbstatus`: A command that lists the current SMB connections for the local host.
- ◆ `smbtar`: A program that backs up SMB shares directly to tape drives on the Linux system.
- ◆ `smbumount`: A program that unmounts a currently mounted Samba share directory.
- ◆ `testparm`: A program that ensures that the Samba configuration file is correct.
- ◆ `winbindd`: A server that resolves names from Windows NT servers.

The following sections describe how to configure and use Samba.

Installing Samba

You may have already installed Samba when you installed Linux. You can check first, and if you don't find Samba on your system, you can easily install it.



To see whether Samba is installed, type **`dpkg -l samba*`** in Debian, Ubuntu, and Xandros or type **`rpm -q samba`** in Fedora and SUSE.



In Debian and Ubuntu, type **apt-get install samba** to install Samba. In Fedora, log in as `root` and type **yum install samba samba-swat**. This installs not only `samba` but also the web configuration interface, SWAT (Samba Web Administration Tool). In SUSE, click Software Management in the YaST Control Center's Software category. Then use YaST's search facility to look for `samba`, select the relevant packages, and install them. As for Xandros, you get Samba when you install Xandros.

After installing the Samba software, you have to configure Samba before you can use it.

Configuring Samba

To set up the Windows file-sharing and print-sharing services, you can either edit the configuration file manually or use a GUI tool. Using the GUI tool is much easier than editing a configuration file. Fedora and SUSE come with GUI tools for configuring the Samba server.



In Fedora, choose System Settings → Advanced → Samba from the KDE desktop to open the Samba Server Configuration window. Enter a valid username and password at the prompt, and the configuration interface that follows lets you create and edit entries in the configuration file `/etc/samba/smb.conf`.



In SUSE, you can configure Samba through the YaST Control Center — choose System → Control Center (YaST) from the main menu. Click Network Services on the left side of the window and then click Samba Server on the right side of the window. In the window that appears, select a workgroup name (YaST displays the name of any existing Windows workgroup on your LAN) and click Next. Then you can select the server type, enable the server, and select what you want to share. After you exit the Samba server configuration utility, YaST stores the Samba settings in configuration files in the `/etc/samba` directory.

After configuring Samba, type the following command in a terminal window to verify that the Samba configuration file is okay:

```
testparm
```

If the command says that it loaded the files okay, you're all set to go. The `testparm` command also displays the contents of the Samba configuration file.



Samba uses the `/etc/samba/smb.conf` file as its configuration file. This is a text file with a syntax similar to that of a Microsoft Windows 3.1 INI file. You can edit that file in any text editor on your Linux system. Like the old Windows INI files, the `/etc/samba/smb.conf` file consists of sections, with a list of parameters in each section. Each section of the `smb.conf` file begins with the name of the section in brackets. The section continues until the next section begins or until the file ends. Each line uses the `name = value` syntax to specify the value of a parameter. As in Windows INI files,

Discovering more about Samba

This chapter is only an introduction to Samba. To find out more about Samba, you can consult the following resources:

- ✓ To view Samba documentation online, visit www.samba.org/samba/docs/man/Samba-HOWTO-Collection.
- ✓ *Using Samba*, 3rd Edition, by Jay Ts, Robert Eckstein, and David Collier-Brown (O'Reilly & Associates, 2007)

You should also visit www.samba.org to keep up with the latest news on Samba development. This site also has links to resources for learning Samba.

comment lines begin with a semicolon (;). In the `/etc/samba/smb.conf` file, comments may also begin with a hash mark (#).



To start the Samba services automatically when the system reboots, type **update-rc.d samba defaults** in Debian, Ubuntu, and Xandros or type **chkconfig -level 35 smb on** in Fedora and SUSE. To start Samba immediately, type **/etc/init.d/smb start** in Fedora and SUSE or type **/etc/init.d/samba start** in Debian, Ubuntu, and Xandros.

Trying out Samba

You can now access the Samba server on the Linux system from one of the Windows systems on the LAN. Double-click the Network Neighborhood icon on the Windows 95/98/ME desktop. On Windows XP, choose Start→My Network Places and then click View Workgroup Computers. All the computers on the same workgroup are shown. In Windows, choose Start→Computer→Network.

When you see the Samba server, you can open it by double-clicking the icon. After you enter your Samba username and password, you can access the folders and printers (if any) on the Samba share.

You can use the `smbclient` program to access shared directories and printers on Windows systems on the LAN and to ensure that your Linux Samba server is working. One quick way to check is to type **smbclient -L** in a terminal window to view the list of services on the Linux Samba server itself.

Book VI

Security

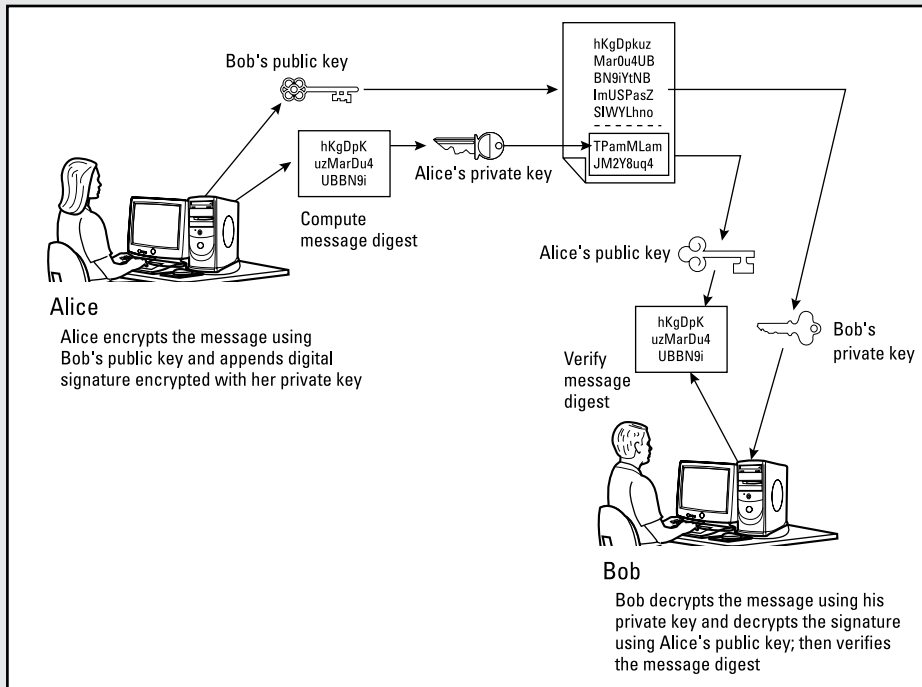

Contents at a Glance

| | |
|---|------------|
| Chapter 1: Introducing Linux Security | 383 |
| Why Worry about Security?..... | 383 |
| Establishing a Security Framework..... | 384 |
| Securing Linux..... | 389 |
| Delving into Computer Security Terminology & Tools | 391 |
| Keeping Up with Security News and Updates..... | 397 |
| Chapter 2: Securing Linux. | 399 |
| Securing Passwords..... | 399 |
| Protecting Files and Directories..... | 402 |
| Encrypting and Signing Files with GnuPG | 406 |
| Monitoring System Security | 412 |
| Securing Internet Services | 413 |
| Using Secure Shell (SSH) for Remote Logins | 415 |
| Setting Up Simple Firewalls | 418 |
| Security Files to Be Aware Of..... | 426 |
| Chapter 3: Computer Security Audits and Vulnerability Testing Types. | 429 |
| Understanding Security Audits | 429 |
| Implementing a Security Test Methodology | 431 |
| Vulnerability Testing Types..... | 440 |
| Exploring Security Testing Tools | 440 |

Chapter 1: Introducing Linux Security

In This Chapter

- ✓ **Establishing a security policy and framework**
- ✓ **Understanding host security issues**
- ✓ **Understanding network security issues**
- ✓ **Translating computer security terminology**
- ✓ **Keeping up with security news and updates**

This chapter explains why you need to worry about security — and offers a high-level view of how to get a handle on security. The idea of an overall security framework is explained and the two key aspects of security — host security and network security — are discussed. This chapter ends by introducing you to the terminology used in discussing computer security.

**LX0-102
Exam**

According to the weighting, 15 percent of the questions on the LX0-102 exam fall under the Security domain. This number should be viewed as being very conservative since so much of administration involves security. You'll find topics related to it in domains such as Administrative Tasks, Essential System Services, Networking Fundamentals, and so on. Because of that, you'll find a lot of security-relevant information in the three chapters of Book 6 and in other chapters as well.

Why Worry about Security?

In today's networked world, you have to worry about your Linux system's security. For a standalone system or a system used in an isolated local area network (LAN), you have to focus on protecting the system from the users, and the users from one another. In other words, you don't want a user to modify or delete system files, whether intentionally or unintentionally — and you don't want a user destroying another user's files (or their own, if you can prevent it).

Since the odds are good that your Linux system is connected to the Internet, you have to secure the system from unwanted accesses over the Internet. These intruders — or *crackers*, as they're commonly known — typically impersonate a user, steal or destroy information, and even deny you access to your own system — known as a *Denial of Service (DoS)*, or *Distributed Denial of Service (DDoS)*, attack.

By its very nature, an Internet connection makes your system accessible to any other system on the Internet. After all, the Internet connects a huge number of networks across the globe. In fact, the client/server architecture of Internet services, such as HTTP (web) and FTP, rely on the wide-open network access the Internet provides. Unfortunately, the easy accessibility to Internet services running on your system also means that anyone on the Net can easily access your system.

If you operate an Internet host that provides information to others, you certainly want everyone to access your system's Internet services, such as FTP and web servers. However, these servers often have vulnerabilities that crackers may exploit to harm your system. You need to know about the potential security risks of Internet services — and the precautions you can take to minimize the risk of someone exploiting the weaknesses of your FTP or web server.

You also want to protect your company's internal network from outsiders, even though your goal is to provide information to the outside world through your web or FTP server. You can protect your internal network by setting up an Internet *firewall* — a controlled-access point to the internal network — and placing the web and FTP servers on a host outside the firewall.

Establishing a Security Framework

The first step in securing your Linux system is to set up a *security policy* — a set of guidelines that state what you enable users (as well as visitors over the Internet) to do on your Linux system. The level of security you establish depends on how you use the Linux system — and on how much is at risk if someone gains unauthorized access to your system.

If you're a system administrator for one or more Linux systems at an organization, you probably want to involve company management, as well as the users, in setting up the security policy. Obviously, you can't create a draconian policy that blocks all access. (That would prevent anyone from effectively working on the system.) On the other hand, if the users are creating or using data valuable to the organization, you have to set up a policy that protects the data from disclosure to outsiders. In other words, the security policy should strike a balance between the users' needs and the need to protect the system.

For a standalone Linux system or a home system that you occasionally connect to the Internet, the security policy can be just a listing of the Internet services that you want to run on the system and the user accounts that you plan to set up on the system. For any larger organization, you probably have one or more Linux systems on a LAN connected to the Internet — preferably through a firewall. (To reiterate, a *firewall* is a device that controls the flow of Internet Protocol — IP — packets between the LAN and the Internet.) In such cases, thinking of computer security systematically — across the entire organization — is best. Figure 1-1 shows the key elements of an organization-wide framework for computer security.

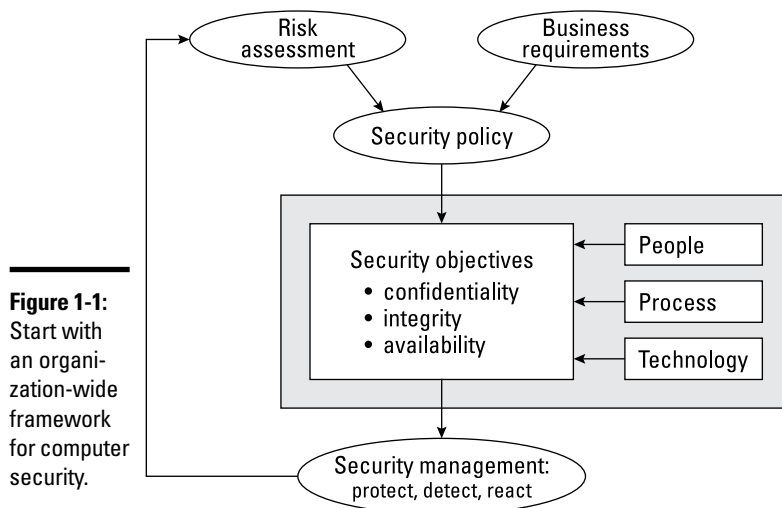

Figure 1-1: Start with an organization-wide framework for computer security.

The security framework outlined in Figure 1-1 focuses on

- ◆ Determining the business requirements for security
- ◆ Performing risk assessments
- ◆ Establishing a security policy
- ◆ Implementing a cybersecurity solution that includes people, process, and technology to mitigate identified security risks
- ◆ Continuously monitoring and managing security

The following sections discuss some of the key elements of the security framework.

Determining business requirements for security

The business requirements for security identify the computer resources and information you have to protect (including any requirements imposed by applicable laws, such as the requirement to protect the privacy of some types of data). Typical security requirements may include items such as the following:

- ◆ Enabling access to information by authorized users
- ◆ Implementing business rules that specify who has access to what information
- ◆ Employing a strong user-authentication system
- ◆ Denying execution to malicious or destructive actions on data

- ◆ Protecting data from end to end as it moves across networks
- ◆ Implementing all security and privacy requirements that applicable laws impose

Performing risk analysis

Risk analysis is all about identifying and assessing risks — potential events that can harm your Linux system. The analysis involves determining the following and performing some analysis to establish the priority for handling the risks:

- ◆ **Threats:** What you're protecting against
- ◆ **Vulnerabilities:** Weaknesses that may be exploited by threats (these are the risks)
- ◆ **Probability:** The likelihood that a threat will exploit the vulnerability
- ◆ **Impact:** The effect of exploiting a specific vulnerability
- ◆ **Mitigation:** What to do to reduce vulnerabilities

Typical threats

Some typical threats to your Linux system include the following:

- ◆ **Denial of Service:** The computer and network are tied up so legitimate users can't make use of the systems. For businesses, Denial of Service (DoS) can mean a loss of revenue. Since bringing a system to its knees with a single computer attack is a bit of a challenge these days, the more common tactic is to point a number of computers at a single site and let them do the dirty work. While the purpose and result are the same as ever, this ganging up is referred to as Distributed Denial of Service (DDoS) attack because more than one computer is attacking the host.
- ◆ **Unauthorized access:** Use of the computer and network by someone who isn't an authorized user. The unauthorized user can steal information or maliciously corrupt or destroy data. Some businesses may be hurt by the negative publicity resulting from the mere act of an unauthorized user gaining access to the system, even if the data shows no sign of explicit damage.
- ◆ **Disclosure of information to the public:** The unauthorized release of information to the public. For example, the disclosure of a password file enables potential attackers to figure out username and password combinations for accessing a system. Exposure of other sensitive information, such as financial and medical data, may be a potential liability for a business.

Typical vulnerabilities

The threats to your system and network come from exploitation of vulnerabilities in your organization's resources — both computer and people. Some common vulnerabilities follow:

- ◆ People's foibles (divulging passwords, losing security cards, and so on)
- ◆ Internal network connections (routers, switches)
- ◆ Interconnection points (gateways — routers and firewalls — between the Internet and the internal network)
- ◆ Third-party network providers (ISPs, long-distance carriers) with looser security
- ◆ Operating system security holes (potential holes in Internet servers, such as those associated with `sendmail`, `named`, and `bind`)
- ◆ Application security holes (known weaknesses in specific applications)

The 1-2-3 of risk analysis (probability and effect)

To perform risk analysis, assign a numeric value to the probability and effect of each potential vulnerability. To develop a workable risk analysis, do the following for each vulnerability or risk:

1. Assign subjective ratings of low, medium, and high to the probability. As the ratings suggest, low probability means a lesser chance that the vulnerability will be exploited; high probability means a greater chance.
2. Assign similar ratings to the effect. What you consider the effect is up to you. If the exploitation of a vulnerability will affect your business greatly, assign it a high effect rating.
3. Assign a numeric value to the three levels — low = 1, medium = 2, and high = 3 — for both probability and effect.
4. Multiply the probability by the effect — you can think of this product as the *risk level*. Then make a decision to develop protections for vulnerabilities that exceed a specific threshold for the product of probability and effect. For example, you may choose to handle all vulnerabilities that have a probability-times-effect value greater than 6.

If you want to characterize the probability and effect with finer gradations, use a scale of 1 through 5 (for example) instead of 1 through 3, and follow the same steps as before.

Establishing a security policy

Using risk analysis and any business requirements that you may have to address (regardless of risk level) as a foundation, you can craft a security policy for the organization. Such a security policy typically addresses high-level objectives such as ensuring the confidentiality, integrity, and availability of data and systems.

The security policy typically addresses the following areas:

- ◆ **Authentication:** What method is used to ensure that a user is the real user? Who gets access to the system? What is the minimum length and complexity of passwords? How often do users change passwords? How long can a user be idle before that user is logged out automatically?
- ◆ **Authorization:** What can different classes of users do on the system? Who can have the `root` password?
- ◆ **Data protection:** What data must be protected? Who has access to the data? Is encryption necessary for some data?
- ◆ **Internet access:** What are the restrictions on users (from the LAN) accessing the Internet? What Internet services (such as web, Internet Relay Chat, and so on) can users access? Are incoming e-mails and attachments scanned for viruses? Is there a network firewall? Are virtual private networks (VPNs) used to connect private networks across the Internet?
- ◆ **Internet services:** What Internet services are allowed on each Linux system? Are there any file servers, mail servers, or web servers? What services run on each type of server? What services, if any, run on Linux systems used as desktop workstations?
- ◆ **Security audits:** Who tests whether the security is adequate? How often is the security tested? How are problems found during security testing handled?
- ◆ **Incident handling:** What are the procedures for handling any computer security incidents? Who must be informed? What information must be gathered to help with the investigation of incidents?
- ◆ **Responsibilities:** Who is responsible for maintaining security? Who monitors log files and audit trails for signs of unauthorized access? Who maintains the security policy?

Implementing security solutions (mitigation)

After you analyze the risks — vulnerabilities — and develop a security policy, you have to select the *mitigation approach*: how to protect against specific vulnerabilities. This is where you develop an overall security solution based on security policy, business requirements, and available technology — a solution that makes use of people, process, and technology and includes the following:

- ◆ Services (authentication, access control, encryption)
- ◆ Mechanisms (username and password, firewalls)
- ◆ Objects (hardware, software)

Because it's impossible to protect computer systems from all attacks, solutions identified through the risk management process must support three integral concepts of a holistic security program:

- ◆ **Protection:** Provides countermeasures such as policies, procedures, and technical solutions to defend against attacks on the assets being protected.
- ◆ **Detection:** Monitors for potential breakdowns in the protective measures that could result in security breaches.
- ◆ **Reaction or Response:** Responds to detected breaches to thwart attacks before damage occurs; often requires human involvement.

Because absolute protection from attacks is impossible to achieve, a security program that doesn't incorporate detection and reaction is incomplete.

Managing security

In addition to implementing security solutions, you have to install security management that continually monitors, detects, and responds to any security incidents.

The combination of the risk analysis, security policy, security solutions, and security management provides the overall security framework. Such a framework helps establish a common level of understanding of security concerns — and a common basis for the design and implementation of security solutions.

Securing Linux

After you define a security policy, you can proceed to secure the system according to the policy. The exact steps depend on what you want to do with the system, whether the system is a server or workstation, and how many users must access the system.

To secure the Linux system, you have to handle two broad categories of security issues:

- ◆ **Host-security issues:** These issues relate to securing the operating system and the files and directories on the system.
- ◆ **Network-security issues:** These issues refer to the threat of attacks over the network connection.



If your host is connecting to a large network, Directory Services can become a significant issue. Directory Services security is outside the scope of this book, but you can find a number of sources addressing the issue with a Google search.

Understanding the host-security issues

Here are some high-level guidelines to address host security. (I cover some of these topics in detail in Chapter 2 of this minibook.)

LXO-102
Exam

- ◆ When installing Linux, select only the package groups that you need for your system. Don't install unnecessary software. For example, if your system is used as a workstation, you don't have to install most of the servers (web server, news server, and so on).
- ◆ Create initial user accounts and make sure that all passwords are strong enough that password-cracking programs can't guess them. Linux includes tools to enforce strong passwords.
- ◆ Set file ownerships and permissions to protect important files and directories.
- ◆ If mandatory access-control capabilities are available, enable them. Support for this feature has been incorporated, through Security Enhanced Linux (SELinux), since kernel 2.6.

LXO-102
Exam

- ◆ Use the GNU Privacy Guard (GnuPG) to encrypt or decrypt files with sensitive information and to authenticate files that you download from the Internet. GnuPG comes with Linux, and you can use the `gpg` command to perform tasks such as encrypting or decrypting a file and digitally signing a file. (See Chapter 2 of this minibook for an explanation of digital signatures.)
- ◆ Use file-integrity checking tools, such as Tripwire, to monitor any changes to crucial system files and directories. Visit www.tripwire.com for the commercial version.
- ◆ Periodically, check various log files for signs of any break-ins or attempted break-ins. These log files are in the `/var/log` directory of your system.
- ◆ Install security updates as soon as they are available and tested. These security updates fix known vulnerabilities in Linux. Be sure to test the update on nonproduction machines before rolling it out to your production servers.

Understanding network-security issues

The issue of security comes up as soon as you connect your organization's internal network to the Internet. You need to think of security even if you connect a single computer to the Internet, but security concerns are more pressing when an entire internal network is opened to the world.

If you're an experienced system administrator, you already know that the cost of managing an Internet presence doesn't worry corporate management; their main concern is security. To get your management's backing for

the website, you have to lay out a plan to keep the corporate network secure from intruders.

You may think that you can avoid jeopardizing the internal network by connecting only external servers, such as web and FTP servers, to the Internet. However, employing this simplistic approach isn't wise. It's like deciding not to drive because you may have an accident. Not having a network connection between your web server and your internal network also has the following drawbacks:

- ◆ You can't use network file transfers, such as FTP, to copy documents and data from your internal network to the web server.
- ◆ Users on the internal network can't access the corporate web server.
- ◆ Users on the internal network don't have access to web servers on the Internet. Such a restriction makes a valuable resource — the web — inaccessible to the users in your organization.

A practical solution to this problem is to set up an Internet firewall and to put the web server on a highly secured host outside the firewall.

In addition to using a firewall, here are some other steps to take to address network security. (I explain these further in Chapter 2 of this minibook.)

- ◆ Enable only those Internet services you need on a system. In particular, don't enable services that aren't properly configured.
- ◆ Use Secure Shell (`ssh`) for remote logins. Don't use the `r` commands, such as `rlogin` and `rsh`.
- ◆ Secure any Internet services, such as FTP or TELNET, that you want to run on your system. You can use the *TCP wrapper* access-control files — `/etc/hosts.allow` and `/etc/hosts.deny` — to secure some of these services. (See Chapter 3 of this minibook for more on the TCP wrapper.)
- ◆ Promptly fix any known vulnerabilities of Internet services that you choose to run. Typically, you can download and install the latest security updates from your Linux distribution's online update sites.

Delving into Computer Security Terminology and Tools

Computer books, magazine articles, and experts on computer security use a number of terms that you need to know in order to understand discussions about computer security (and to communicate effectively with security vendors).

LX0-102
Exam

Table 1-1 describes some of the commonly used computer security terms. If you're taking the LX0-102 exam, port scanning and `setuid` are important.

| Table 1-1 Common Computer Security Terminology | |
|---|--|
| <i>Term</i> | <i>Description</i> |
| Application gateway | A proxy service that acts as a gateway for application-level protocols, such as FTP, HTTP, NNTP, and SSH. |
| Authentication | The process of confirming that a user is indeed who he or she claims to be. The typical authentication method is a challenge-response method wherein the user enters a username and secret password to confirm his or her identity. |
| Backdoor | A security weakness that a cracker places on a host to bypass security features. |
| Bastion host | A highly secured computer that serves as an organization's main point of presence on the Internet. A bastion host typically resides on the perimeter network, but a <i>dual-homed host</i> (with one network interface connected to the Internet and the other to the internal network) is also a bastion host. |
| Buffer overflow | A security flaw in a program that enables a cracker to send an excessive amount of data to that program and to overwrite parts of the running program with code in the data being sent. The result is that the cracker can execute arbitrary code on the system and possibly gain access to the system as a privileged user. The new <code>exec-shield</code> feature of the Linux kernel protects against buffer overflows. |
| Certificate | An electronic document that identifies an entity (such as an individual, an organization, or a computer) and associates a public key with that identity. A certificate contains the certificate holder's name, a serial number, an expiration date, a copy of the certificate holder's public key, and the digital signature of the certificate authority so a recipient can verify that the certificate is real. |
| Certificate authority (CA) | An organization that validates identities and issues certificates. |
| Confidentiality | Of data, a state of being accessible to no one but authorized users (usually achieved by encryption). |
| Cracker | A person who breaks into (or attempts to break into) a host, often with malicious intent. |
| Decryption | The process of transforming encrypted information into its original, intelligible form. |

| <i>Term</i> | <i>Description</i> |
|--------------------------------------|--|
| Denial of Service (DoS) | An attack that uses so many of the resources on your computer and network that legitimate users can't access and use the system. From a single source, the attack overwhelms the target computer with messages and blocks legitimate traffic. It can prevent one system from being able to exchange data with other systems or prevent the system from using the Internet. |
| Digital signature | A one-way MD5 (Message Digest algorithm 5) or SHA-1 (Secure Hash Algorithm-1) hash of a message encrypted with the private key of the message originator, used to verify the integrity of a message and ensure nonrepudiation. |
| Distributed Denial of Service (DDoS) | A variant of the Denial of Service attack that uses a coordinated attack from a distributed system of computers rather than a single source. It often makes use of worms to spread to — and take control of — multiple computers that can then attack the target. |
| DMZ | Another name for the perimeter network. (DMZ originally stood for <i>demilitarized zone</i> , the buffer zone separating the warring North and South in Korea and Vietnam.) |
| Dual-homed host | A computer with two network interfaces (think of each network as a home). |
| Encryption | The process of transforming information so it's unintelligible to anyone but the intended recipient. The transformation is performed by a mathematical operation between a key and the information. |
| Exploit tools | Publicly available and sophisticated tools that intruders of various skill levels can use to determine vulnerabilities and gain entry into targeted systems. |
| Firewall | A controlled-access gateway between an organization's internal network and the Internet. A dual-homed host can be configured as a firewall. |
| Hash | The result when a mathematical function converts a message into a fixed-size numeric value known as a <i>message digest</i> (or <i>hash</i>). The MD5 algorithm, for example, produces a 128-bit message digest; SHA-1 generates a 160-bit message digest. The hash of a message is encrypted with the private key of the sender to produce the digital signature. |

(continued)

Table 1-1 (continued)

| <i>Term</i> | <i>Description</i> |
|------------------------------|---|
| Host | A computer on a network that's configured to offer services to other computers on the network. |
| Integrity | Of received data, a state of being the same as originally sent (that is, unaltered in transit). |
| IP spoofing | An attack in which a cracker figures out the IP address of a trusted host and then sends packets that appear to come from the trusted host. The attacker can send packets but can't see responses. However, the attacker can predict the sequence of packets and essentially send commands that set up a backdoor for future break-ins. |
| IPSec (IP Security Protocol) | A security protocol for the network layer of the OSI networking model, designed to provide cryptographic security services for IP packets. IPSec provides encryption-based authentication, integrity, access control, and confidentiality. (For information on IPSec for Linux, visit www.ipsec-howto.org .) |
| Logic bombs | A form of sabotage in which a programmer inserts code that causes the program to perform a destructive action when some triggering event occurs, such as terminating the programmer's employment. |
| Nonrepudiation | A security feature that prevents the sender of data from being able to deny ever having sent the data. |
| Packet | A collection of bytes, assembled according to a specific protocol, that serves as the basic unit of communication on a network. On TCP/IP networks, for example, the packet may be referred to as an <i>IP packet</i> or a <i>TCP/IP packet</i> . |
| Packet filtering | Selective blocking of packets according to type of packet (as specified by the source and destination IP address or port). |
| Perimeter network | A network between the Internet and the protected internal network. The perimeter network (also known as DMZ) is where the bastion host resides. |
| Port scanning | A method of discovering which ports are open (in other words, which Internet services are enabled) on a system, performed by sending connection requests to the ports, one by one. This procedure is usually a precursor to further attacks; two port-scanning tools to know are <i>nmap</i> , and <i>netstat</i> . |

| <i>Term</i> | <i>Description</i> |
|---------------------------------|--|
| Proxy server | A server on the bastion host that enables internal clients to access external servers (and enables external clients to access servers inside the protected network). There are proxy servers for various Internet services, such as FTP and HTTP. |
| Public key cryptography | An encryption method that uses a pair of keys — a private key and a public key — to encrypt and decrypt the information. Anything encrypted with the public key is decrypted only with the corresponding private key, and vice versa. |
| Public Key Infrastructure (PKI) | A set of standards and services that enables the use of public key cryptography and certificates in a networked environment. PKI facilitates tasks such as issuing, renewing, and revoking certificates, and generating and distributing public and private key pairs. |
| Screening router | An Internet router that filters packets. |
| setuid program | A program that runs with the permissions of the owner regardless of who runs the program. For example, if <code>root</code> owns a <code>setuid/suid</code> program, that program has <code>root</code> privileges regardless of who started the program. Crackers often exploit vulnerabilities in <code>setuid</code> programs to gain privileged access to a system. Similarly, <code>sgid</code> programs are used to run with the permissions of the group, regardless of who runs the program, and have their own similar vulnerabilities. |
| Sniffer | Synonymous with <i>packet sniffer</i> — a program that intercepts routed data and examines each packet in search of specified information, such as passwords transmitted in clear text. |
| Spyware | Any software that covertly gathers user information through the user's Internet connection and usually transmits that information in the background to someone else. Spyware can also gather information about e-mail addresses and even passwords and credit card numbers. Spyware is similar to a Trojan horse in that users are tricked into installing spyware when they install something else. |
| Symmetric key encryption | An encryption method wherein the same key is used to encrypt and decrypt the information. |
| Threat | An event or activity, deliberate or unintentional, with the potential for causing harm to a system or network. |

(continued)

Table 1-1 (continued)

| <i>Term</i> | <i>Description</i> |
|---------------|---|
| Trojan horse | A program that masquerades as a benign program but is really a backdoor used for attacking a system. Attackers often install a collection of Trojan horse programs that enable the attacker to freely access the system with <code>root</code> privileges, yet hide that fact from the system administrator. Such collections of Trojan horse programs are called <i>rootkits</i> . |
| Virus | A self-replicating program that spreads from one computer to another by attaching itself to other programs. |
| Vulnerability | A flaw or weakness that may cause harm to a system or network. |
| War-dialing | Simple programs that dial consecutive phone numbers looking for modems. |
| War-driving | A method of gaining entry into wireless computer networks that uses a laptop, antennas, and a wireless network card and involves patrolling locations to gain unauthorized access. |
| Worm | A self-replicating program that copies itself from one computer to another over a network. |

LX0-102
Exam

Table 1-2 lists some of the commonly used computer security-related tools. Some of these you've seen before as they were discussed in other chapters where they related to the topics there; some others are new as they are relevant to security only.

Table 1-2 Common Computer Security Tools

| <i>Tool</i> | <i>Description</i> |
|--------------------|---|
| <code>chage</code> | With this command, you can modify the time between required password changes (both minimum and maximum number of days), the number of days of warning to be given that a change must be made, and expiration date. |
| <code>find</code> | One of the most powerful all-around tools, this command allows you to find almost anything on machine if you can come up with the right syntax. Among the plethora of choices, you can find files created by a user, by a group, on a certain date, with certain permissions. |

| <i>Tool</i> | <i>Description</i> |
|----------------------|---|
| <code>lsdf</code> | An acronym for list open files, this utility does just that. Depending on the parameters used, you can choose to see files opened by a process, or by a user. |
| <code>netstat</code> | To see the status of the network, including network connections, routing tables and statistics per interface, this tool does it all. A similar command, <code>ss</code> , is intended to replace much of the functionality here. |
| <code>nmap</code> | This tool is used to scan the network and essentially create a map of what is available on it. This capability makes it an ideal tool for port scanning and security auditing. |
| <code>passwd</code> | A utility (not the file by the same name that holds user account information), with which users can change their passwords at the command line whenever necessary. Many users don't know this utility exists, so they change their passwords when required, through one of the graphical interface tools. |
| <code>su</code> | To temporarily become another user, <code>su</code> can be used within the current user's session. Another shell is created; upon exiting from this second shell, the user goes back to the original session. This utility can be used to become the <code>root</code> user or any other user (provided the corresponding password is given). |
| <code>sudo</code> | Instead of creating a new session (as <code>su</code> requires) to perform a job with elevated privileges, <code>sudo</code> enables the user to just run that task. |
| <code>ulimit</code> | Resource limits on shells can be set or viewed using this command to keep one user from excessively hogging system resources. |
| <code>usermod</code> | This utility can be thought of as an enhanced version of <code>chage</code> . Not only can it be used to set/change password expiration parameters, it can also be used to specify a default shell, lock/unlock an account, and so on. |

Keeping Up with Security News and Updates

To keep up with the latest security alerts, you may want to visit one or both of the following sites on a daily basis:

- ◆ CERT Coordination Center (CERT/CC) at www.cert.org
- ◆ United States Computer Emergency Readiness Team (US-CERT) at www.us-cert.gov

If you prefer to receive regular security updates through e-mail, you can also sign up for (subscribe to) various mailing lists:

- ◆ **Focus on Linux:** Fill out the form at www.securityfocus.com/archive to subscribe to this mailing list focused on Linux security issues.
- ◆ **US-CERT National Cyber Alert System:** Follow the directions at www.us-cert.gov to subscribe to this mailing list. The Cyber Alert System features four categories of security information through its mailing lists:
 - *Technical Cyber Security Alerts:* Alerts that provide technical information about vulnerabilities in various common software products.
 - *Cyber Security Alerts:* Alerts sent when vulnerabilities affect the general public. Each alert outlines the steps and actions that non-technical home and corporate computer users can take to protect themselves from attacks.
 - *Cyber Security Bulletins:* Biweekly summaries of security issues and new vulnerabilities along with patches, workarounds, and other actions that users can take to help reduce risks.
 - *Cyber Security Tips:* Advice on common security issues for nontechnical computer users.



Finally, check your distribution's website for updates that may fix any known security problems with that distribution:

- ◆ In Debian and Ubuntu, you can update the system with the commands `apt-get update` followed by `apt-get upgrade`.
- ◆ For Fedora, the website is <http://fedoraproject.org>.
- ◆ In SUSE, use YaST Online Update to keep your system up to date.
- ◆ In Xandros, obtain the latest updates from Xandros Networks.

Chapter 2: Securing Linux

In This Chapter

- ✓ **Securing passwords on your Linux system**
- ✓ **Protecting the system's files and directories**
- ✓ **Using GnuPG to encrypt and sign files**
- ✓ **Monitoring the security of your system**
- ✓ **Hardening Internet services**
- ✓ **Using Secure Shell for secure remote logins**
- ✓ **Setting up simple firewalls and enabling packet filtering**

To secure your Linux system, you have to pay attention to both host security and network security. The distinction between the two types of security is somewhat arbitrary because securing the network involves securing the applications on the host that relate to what Internet services your system offers.

This chapter first examines host security and then explains how you can secure network services (mostly by not offering unnecessary services), how you can use a firewall to stop unwanted network packets from reaching your network, and how to use Secure Shell for secure remote logins.

Host is the techie term for your Linux system — especially when you use it to provide services on a network. But the term makes sense even when you think of the computer by itself; it's the host for everything that runs on it: the operating system and all applications. A key aspect of computer security is to secure the host.

Securing Passwords

Historically, Unix passwords are stored in the `/etc/passwd` file, which any user can read. For example, a typical old-style `/etc/passwd` file entry for the `root` user looks like this:

```
root:t6Z7NWDK1K8sU:0:0:root:/root:/bin/bash
```

The fields are separated by colons (:), and the second field contains the password in encrypted form. To check whether a password is valid, the `login` program encrypts the plain-text password the user enters and compares the password with the contents of the `/etc/passwd` file. If they match, the user is allowed to log in.

Password-cracking programs work just like the login program, except these programs choose one word at a time from a dictionary, encrypt the word, and compare the encrypted word with the encrypted passwords in the `/etc/passwd` file for a match. To crack the passwords, the intruder needs the `/etc/passwd` file. Often crackers use weaknesses of various Internet servers (such as mail and FTP) to get a copy of the `/etc/passwd` file.

Passwords have become more secure in Linux due to several improvements, including shadow passwords and pluggable authentication modules, or PAMs (described in the next two sections). You can install shadow passwords or a PAM easily while you install Linux. During Linux installation, you typically get a chance to configure the authentication. If you enable MD5 security and enable shadow passwords, you automatically enable more secure passwords in Linux.

Shadow passwords

Obviously, leaving passwords lying around where anyone can get at them — even if the passwords are encrypted — is bad security. So instead of storing passwords in the `/etc/passwd` file (which any user can read), Linux now stores them in a *shadow password file*, `/etc/shadow`. Only the superuser (`root`) can read this file. For example, here's the entry for `root` in the new-style `/etc/passwd` file:

```
root:x:0:0:root:/root:/bin/bash
```

In this case, note that the second field contains an `x` instead of an encrypted password. The `x` is the *shadow password*; the actual encrypted password is now stored in the `/etc/shadow` file, where the entry for `root` is like this:

```
root:$1$AAAni/yN$uESHbzÜpy9Cgfoo1Bf0tS0:11077:0:99999:7:-1:-1:134540356
```

The format of the `/etc/shadow` entries with colon-separated fields resembles the entries in the `/etc/passwd` file, but the meanings of most of the fields differ. The first field is still the username, and the second one is the encrypted password.

The remaining fields in each `/etc/shadow` entry control when the password expires. You don't have to interpret or change these entries in the `/etc/shadow` file. Instead, use the `chage` command to change the password expiration information. For starters, you can check a user's password expiration information by using the `chage` command with the `-l` option, as follows. (In such a case, you have to be logged in as `root`.)

```
chage -l root
```

This command displays expiration information, including how long the password lasts and how often you can change the password.

If you want to ensure that the user is forced to change a password at regular intervals, you can use the `-M` option to set the maximum number of days that a password stays valid. For example, to make sure that user `kdulaney` is prompted to change the password in 90 days, log in as `root` and type the following command:

```
chage -M 90 kdulaney
```

You can use the command for each user account to ensure that all passwords expire when appropriate and that all users must choose new passwords.

Pluggable authentication modules (PAMs)

In addition to improving the password file's security by using shadow passwords, Linux also improves the encryption of the passwords stored in the `/etc/shadow` file by using the MD5 message-digest algorithm described in RFC 1321 (www.ietf.org/rfc/rfc1321.txt or www.cse.ohio-state.edu/cgi-bin/rfc/rfc1321.html). MD5 reduces a message of any length to a 128-bit message digest (or *fingerprint*) of a document so that you can digitally sign it by encrypting it with your private key. MD5 works quite well for password encryption, too.

Another advantage of MD5 over older-style password encryption is that the older passwords were limited to a maximum of eight characters; new passwords (encrypted with MD5) can be much longer. Longer passwords are harder to guess, even if the `/etc/shadow` file falls into the wrong hands.

You can tell that MD5 encryption is in effect in the `/etc/shadow` file. The encrypted passwords are longer and they all sport the `1` prefix, as in the second field of the following sample entry:

```
root:$1$AAAni/yN$uESHbzUpy9Cgfoo1Bf0tS0:11077:0:99999:7:-1:-1:134540356
```

An add-on program module called a *pluggable authentication module* (PAM) performs the MD5 encryption. Linux PAMs provide a flexible method for authenticating users. By setting the PAM's configuration files, you can change your authentication method on-the-fly, without modifying vital programs that verify a user's identity (such as `login` and `passwd`).

Linux uses PAM capabilities extensively. The PAMs reside in many different modules (more on this momentarily); their configuration files are in the `/etc/pam.d` directory of your system. Check out the contents of this directory on your system by typing the following command:

```
ls /etc/pam.d
```

Each configuration file in this directory specifies how users are authenticated for a specific utility.

Protecting Files and Directories

One important aspect of securing the host is to protect important system files — and the directories that contain these files. You can protect the files through file ownership and the permission settings that control who can read, write, or (in the case of executable programs) execute the file.

The default Linux file security is controlled through the following settings for each file or directory:

- ◆ User ownership
- ◆ Group ownership
- ◆ Read, write, execute permissions for the owner
- ◆ Read, write, execute permissions for the group
- ◆ Read, write, execute permissions for others (everyone else)

Viewing ownerships and permissions

You can see settings related to ownership and permissions for a file when you look at a detailed listing with the `ls -l` command. For example, type the following command to see the detailed listing of the `/etc/inittab` file:

```
ls -l /etc/inittab
```

The resulting listing looks something like this:

```
-rw-r--r-- 1 root root 1666 Feb 16 07:57 /etc/inittab
```

The first set of characters describes the file permissions for user, group, and others. The third and fourth fields show the user and group that own this file. In this case, both user and group names are the same: `root`.

Changing file ownerships

You can set the user and group ownerships with the `chown` command. For example, if the file `/dev/hda` should be owned by the user `root` and the group `disk`, you type the following command as `root` to set up this ownership:

```
chown root.disk /dev/hda
```

To change the group ownership alone, use the `chgrp` command. For example, here's how you can change the group ownership of a file from whatever it was earlier to the group named `accounting`:

```
chgrp accounting ledger.out
```

Changing file permissions

Use the `chmod` command to set the file permissions. To use `chmod` effectively, you have to specify the permission settings. One way is to concatenate one or more letters from each column of Table 2-1, in the order shown (Who/Action/Permission).

| <i>Who</i> | <i>Action</i> | <i>Permission</i> |
|------------|-----------------|-------------------|
| u (user) | + (add) | r (read) |
| g (group) | - (remove) | w (write) |
| o (others) | = (assign) | x (execute) |
| a (all) | s (set user ID) | |

To give everyone read and write access to all files in a directory, type **`chmod a+rw *`**. On the other hand, to permit everyone to execute a specific file, type **`chmod a+x filename`**.

Another way to specify a permission setting is to use a three-digit sequence of numbers. In a detailed listing, the read, write, and execute permission settings for the user, group, and others appear as the sequence

```
rwXrwxrwx
```

with dashes in place of letters for disallowed operations. Think of `rwXrwxrwx` as three occurrences of the string `rwX`. Now assign the values `r=4`, `w=2`, and `x=1`. To get the value of the sequence `rwX`, simply add the values of `r`, `w`, and `x`. Thus `rwX = 7`. With this formula, you can assign a three-digit value to any permission setting. For example, if the user can read and write the file but everyone else can only read the file, the permission setting is `rw-r--r--` (that's how it appears in the listing), and the value is 644. Thus, if you want all files in a directory to be readable by everyone but writable only by the user, use the following command:

```
chmod 644 *
```

Setting default permission

What permission setting does a file get when you (or a program) create a new file? The answer is in what is known as the *user file-creation mask*, which you can see and set by using the `umask` command.

Type **`umask`**, and the command prints a number showing the current file-creation mask. For the `root` user, the mask is set to 022, whereas the mask

for other users is 002. To see the effect of this file-creation mask and to interpret the meaning of the mask, follow these steps:

1. Log in as root and type the following command:

```
touch junkfile
```

This command creates a file named `junkfile` with nothing in it.

2. Type `ls -l junkfile` to see that file's permissions.

You see a line similar to the following:

```
-rw-r--r-- 1 root root 0 Aug 24 10:56 junkfile
```

Interpret the numerical value of the permission setting by converting each three-letter permission in the first field (excluding the very first letter) to a number between 0 and 7. For each letter that's present, the first letter gets a value of 4, the second letter is 2, and the third is 1. For example, `rw-` translates to $4+2+0$ (because the third letter is missing), or 6. Similarly, `r--` is $4+0+0 = 4$. Thus the permission string `-rw-r--r--` becomes 644.

3. Subtract the numerical permission setting from 666 and what you get is the `umask` setting.

In this case, $666 - 644$ results in a `umask` of 022.

Thus a `umask` of 022 results in a default permission setting of $666 - 022 = 644$. When you rewrite 644 in terms of a permission string, it becomes `rw-r--r--`.

To set a new `umask`, type **`umask`** followed by the numerical value of the mask. Here is how you go about it:

1. Figure out what permission settings you want for new files.

For example, if you want new files that can be read and written only by the owner and no one else, the permission setting looks like this:

```
rw-----
```

2. Convert the permissions into a numerical value by using the conversion method that assigns 4 to the first field, 2 to the second, and 1 to the third.

Thus, for files that are readable and writable only by their owner, the permission setting is 600.

3. Subtract the desired permission setting from 666 to get the value of the mask.

For a permission setting of 600, the mask becomes $666 - 600 = 066$.

4. Use the `umask` command to set the file-creation mask by typing

```
umask 066
```



A default `umask` of 022 is good for system security because it translates to files that have read and write permission for the owner and read permissions for everyone else. The bottom line is that you don't want a default `umask` that results in files that are writable by the whole world.

Checking for set user ID permission

Another permission setting can be a security hazard. This permission setting, called the *set user ID* (or `setuid` and/or `suid` for short), applies to executable files. When the `suid` permission is enabled, the file executes under the user ID of the file's owner. In other words, if an executable program is owned by `root` and the `suid` permission is set, the program runs as if `root` is executing it — no matter who executed the program. The `suid` permission means that the program can do a lot more (for example, read all files, create new files, and delete files) than what a normal user program can do. Another risk is that if a `suid` program file has a security hole, crackers can do a lot more damage through such programs than through other vulnerabilities.

You can find all `suid` programs with a simple `find` command:

```
find / -type f -perm +4000
```

You see a list of files such as the following:

```
/bin/su
/bin/ping
/bin/eject
/bin/mount
/bin/ping6
/bin/umount
/opt/kde4/bin/fileshareset
/opt/kde4/bin/artswrapper
/opt/kde4/bin/kcheckpass
. . . lines deleted . . .
```

Many of the programs have the `suid` permission because they need it, but check the complete list and make sure that there are no strange `suid` programs (for example, `suid` programs in a user's home directory).

For example, if you type `ls -l /bin/su`, you see the following permission settings:

```
-rwsr-xr-x 1 root root 25756 Aug 19 17:06 /bin/su
```

The `s` in the owner's permission setting (`-rws`) tells you that the `suid` permission is set for the `/bin/su` file, which is the executable file for the `su` command that you can use to become `root` or another user.

Encrypting and Signing Files with GnuPG

Linux comes with the *GNU Privacy Guard* (GnuPG, or simply GPG) encryption and authentication utility. With GPG, you can create your public and private key pair, encrypt files using your key, and also digitally sign a message to authenticate that it's really from you. If you send a digitally signed message to someone who has your public key, the recipient can verify that it was you who signed the message.

Understanding public key encryption

The basic idea behind *public key encryption* is to use a pair of keys — one private and the other public — that are related but can't be used to guess one from the other. Anything encrypted with the private key can be decrypted only with the corresponding public key, and vice versa. The public key is for distribution to other people while you keep the private key in a safe place.

You can use public key encryption to communicate securely with others; Figure 2-1 illustrates the basic idea. Suppose Alice wants to send secure messages to Bob. Each of them generates public key and private key pairs, after which they exchange their public keys. Then, when Alice wants to send a message to Bob, she simply encrypts the message using Bob's public key and sends the encrypted message to him. Now the message is secure from eavesdropping because only Bob's private key can decrypt the message — and only Bob has that key. When Bob receives the message, he uses his private key to decrypt the message and read it.

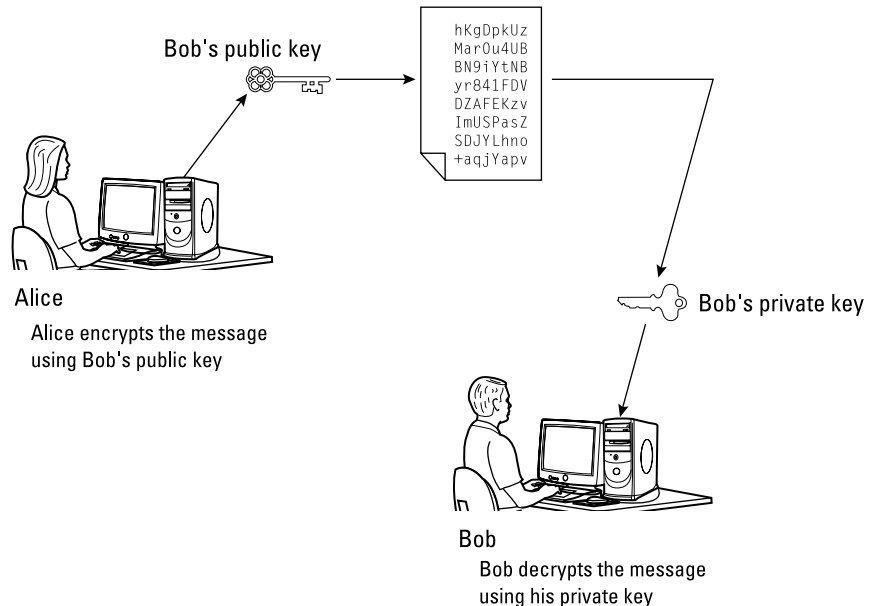

Figure 2-1: Bob and Alice can communicate securely with public key encryption.

At this point, you need to stop and think and say, “Wait a minute! How does Bob know the message really came from Alice? What if someone else uses Bob’s public key and sends a message as if it came from Alice?” This situation is where digital signatures come in.

Understanding digital signatures

The purpose of *digital*, or electronic, *signatures* is the same as pen-and-ink signatures, but how you sign digitally is different. Unlike a pen-and-ink signature, your digital signature depends on the message you’re signing. The first step in creating a digital signature is to apply a mathematical function to the message and reduce it to a fixed-size message digest (also called a *hash* or a *fingerprint*). No matter how big your message, the message digest is usually 128 or 160 bits, depending on the hashing function.

The next step is to apply public key encryption. Simply encrypt the message digest with your private key, and you get the digital signature for the message. Typically, the digital signature is added to the end of the message, and voilà — you get an electronically signed message.

What good does the digital signature do? Well, anyone who wants to verify that the message is indeed signed by you takes your public key and decrypts the digital signature. What that person gets is the message digest (the encrypted hash) of the message. Then he or she applies the same hash function to the message and compares the computed hash with the decrypted value. If the two match, no one has tampered with the message. Because your public key was used to verify the signature, the message must have been signed with the private key known only to you. So the message must be from you!

In the theoretical scenario of Alice sending private messages to Bob, Alice can digitally sign her message to make sure that Bob can tell that the message is really from her. Figure 2-2 illustrates the use of digital signatures along with normal public key encryption.

Here’s how Alice sends her private message to Bob with the assurance that Bob can really tell it’s from her:

1. Alice uses software to compute the message digest of the message and then encrypts the digest by using her private key. This is her digital signature for the message.
2. Alice encrypts the message (again, using some convenient software *and* Bob’s public key).
3. She sends both the encrypted message and the digital signature to Bob.
4. Bob decrypts the message, using his private key.
5. Bob decrypts the digital signature, using Alice’s public key. This gives him the message digest.

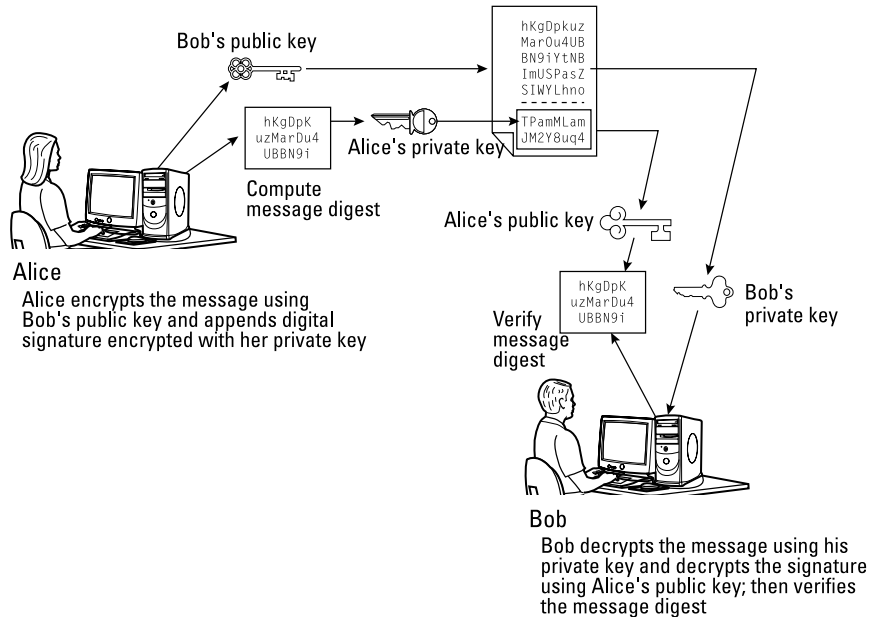

Figure 2-2: Alice can digitally sign her message so that Bob can tell it's really from her.

6. Bob computes the message digest of the message and compares it with what he got by decrypting the digital signature.
7. If the two message digests match, Bob can be sure that the message really came from Alice.

Using GPG

GPG includes the tools you need to use public key encryption and digital signatures. You can figure out how to use GPG gradually as you begin using encryption. The following shows you some of the typical tasks you can perform with GPG.

Generating the key pair

The steps for generating the key pairs are as follows:

1. Type `gpg --gen-key`.

If you're using `gpg` for the first time, it creates a `.gnupg` directory in your home directory and a file named `gpg.conf` in that directory. Then GPG asks what kind of keys you want:

```
Please select what kind of key you want:
(1) DSA and ElGamal (default)
(2) DSA (sign only)
(4) RSA (sign only)
Your selection?
```

2. **Press Enter for the default choice because it's good enough.**
GPG then prompts you for the key size (the number of bits).
3. **Press Enter again to accept the default value of 2,048 bits.**
GPG asks you when the keys expire. The default is to never expire.
4. **If the default is what you want (and why not?), press Enter.**
5. **When GPG asks if you really want the keys to never expire, press the Y key to confirm.**
GPG prompts you for your name, your e-mail address, and finally a comment to make it easier to associate the key pair with your name.
6. **Type each piece of requested information and press Enter.**
7. **When GPG gives you a chance to change the information or confirm it as is, confirm by typing o and pressing Enter.**
GPG next prompts you for a passphrase that protects your private key.
8. **Type a long phrase that includes lowercase and uppercase letters, numbers, and punctuation marks — the longer the better — and then press Enter.**

Be careful to choose a passphrase that you can easily remember.

GPG generates the keys. It may ask you to perform some work on the PC so that the random-number generator can generate enough random numbers for the key-generation process.



Exchanging keys

To communicate with others, you have to give them your public key. You also have to get public keys from those who may send you a message (or someone who might sign a file and you want to verify the signature). GPG keeps the public keys in your key ring. (The *key ring* is simply the public keys stored in a file, but it sounds nice to call it a key ring because everyone has a key ring in the real world, and these are keys of a sort, right?) To list the keys in your key ring, type

```
gpg --list-keys
```

To send your public key to someone or to place it on a website, you have to export the key to a file. The best way is to put the key in what GPG documentation calls an *ASCII-armored* format, with a command like this:

```
gpg --armor --export kdulaney@insightbb.com > kdulaneykey.asc
```

This command saves the public key in an ASCII-armored format (it basically looks like garbled text) in the file named `kdulaneykey.asc`. You would replace the e-mail address with your e-mail address (the one you used when you created the key) and replace the output filename to something different.

After you export the public key to a file, you can mail that file to others or place it on a website for use by others.

When you import a key from someone, you typically get it in an ASCII-armored format as well. For example, if you have a `us-cert@us-cert.gov` GPG public key in a file named `uscertkey.asc` (obtained from the link at www.us-cert.gov/pgp/email.html), you then import it into the key ring with the following command:

```
gpg --import uscertkey.asc
```

Use the `gpg --list-keys` command to verify that the key is in your key ring. For example, here's what you might see when typing **gpg --list-keys** on the system:

```
/home/kdulaney/.gnupg/pubring.gpg
-----
pub 1024D/7B38A728 2013-08-28
uid Kristin Dulaney <kdulaney@insightbb.com>
sub 2048g/3BD6D418 2013-08-28
pub 2048R/F0E187D0 2014-09-08 [expires: 2014-10-01]
uid US-CERT Operations Key <us-cert@us-cert.gov>
```

The next step is to check the fingerprint of the new key. Type the following command to get the fingerprint of the US-CERT key:

```
gpg --fingerprint us-cert@us-cert.gov
```

GPG prints the fingerprint:

```
pub 2048R/F0E187D0 2013-09-08 [expires: 2014-10-01]
Key fingerprint = 049F E3BA 240B 4CF1 3A76 06DC 1868 49EC F0E1 87D0
uid US-CERT Operations Key <us-cert@us-cert.gov>
```

At this point, you need to verify the key fingerprint with someone at the US-CERT organization.

If you think the key fingerprint is good, you can sign the key and validate it. Here's the command you use to sign the key:

```
gpg --sign-key us-cert@us-cert.gov
```

GPG asks for confirmation and then prompts you for your passphrase. After that, GPG signs the key.

Because key verification and signing is a potential weak link in GPG, be careful about what keys you sign. By signing a key, you basically say that you trust the key to be from that person or organization.



Signing a file

You may find signing files useful if you send a file to someone and want to assure the recipient that no one tampered with the file and that you did, in fact, send the file. GPG makes signing a file easy. You can compress and sign a file named `message` with the following command:

```
gpg -o message.sig -s message
```

To verify the signature, type

```
gpg --verify message.sig
```

To get back the original document, simply type

```
gpg -o message --decrypt message.sig
```

Sometimes you don't care about keeping a message secret, but you simply want to sign it to indicate that the message is from you. In such a case, you can generate and append a clear-text signature with the following command:

```
gpg -o message.asc --clearsign message
```

This command basically appends a clear-text signature to the text message. Here's a typical clear-text signature block:

```
-----BEGIN PGP SIGNATURE-----  
Version: GnuPG v1.4.2 (GNU/Linux)  
iD8DBQFDEhAtaHWlHhs4pygRAhiqAJ9Qj0pPMgKVBuokDyUZaEYVsp6RIQCfaoBm  
9zCwrSAG9mo2DXJvbKS3ri8=  
=2uc/  
-----END PGP SIGNATURE-----
```

When a message has a clear-text signature appended, you can use GPG to verify the signature with the following command:

```
gpg --verify message.asc
```

If you had indeed signed the message, the last line of the output says that it's a good signature.

Encrypting and decrypting documents

To encrypt a message meant for a recipient, you can use the `--encrypt` (or `-e`) GPG command. Here's how you might encrypt a message for US-CERT using its GPG key:

```
gpg -o message.gpg -e -r us-cert@us-cert.gov message
```

The message is encrypted using the US-CERT public key (without a signature, but you can add the signature with the `-s` command).

When US-CERT receives the `message.gpg` file, the recipient has to decrypt it using US-CERT's private key. Here's the command someone at US-CERT can use:

```
gpg -o message --decrypt message.gpg
```

GPG then prompts for the passphrase to unlock the US-CERT private key, decrypts the message, and saves the output in the file named `message`.

If you simply want to encrypt a file and no one else has to decrypt the file, you can use GPG to perform *symmetric encryption*. In this case, you provide a passphrase to encrypt the file with the following GPG command:

```
gpg -o secret.gpg -c somefile
```

GPG prompts you for the passphrase and asks you to repeat the passphrase (to make sure that you didn't mistype anything). Then GPG encrypts the file using a key generated from the passphrase.

To decrypt a file encrypted with a symmetric key, type

```
gpg -o myfile --decrypt secret.gpg
```

GPG prompts you for the passphrase. If you enter the correct passphrase, GPG decrypts the file and saves the output (in this example) in the file named `myfile`.

Monitoring System Security

Even if you secure your system, you have to monitor the log files periodically for signs of intrusion. You may want to use Tripwire (a good tool for detecting any changes made to the system files) so that you can monitor the integrity of critical system files and directories. Your Linux system probably doesn't come with the Tripwire package. To use Tripwire, you have to buy it from www.tripwire.com. After you purchase and install Tripwire, you can configure it to monitor any changes to specified system files and directories on your system.

Periodically examine the log files in the `/var/log` directory and its sub-directories. Many Linux applications, including some servers, write log information by using the logging capabilities of `syslogd` or `rsyslogd`. On Linux systems, the log files written by `syslogd` and `rsyslogd` reside in the `/var/log` directory. Make sure that only the `root` user can read and write these files.



The `syslogd` configuration file is `/etc/syslog.conf`, and the `rsyslogd` configuration file (existing on many newer systems) is `/etc/rsyslog.conf`. The default configuration of `syslogd` generates the necessary log files; however, if you want to examine and understand the configuration file, type **man syslog.conf** for more information.

Securing Internet Services

For an Internet-connected Linux system (or even one on a TCP/IP LAN that's not connected to the Internet), a significant threat is that someone could use one of many Internet services to gain access to your system. Each service — such as mail, web, or FTP — requires running a server program that responds to client requests arriving over the TCP/IP network. Some of these server programs have weaknesses that can allow an outsider to log in to your system — maybe with `root` privileges. Luckily, Linux comes with some facilities that you can use to make the Internet services more secure.



Potential intruders can employ a *port-scanning tool* — a program that attempts to establish a TCP/IP connection at a port and then looks for a response — to check which Internet servers are running on your system. Then, to gain access to your system, the intruders can potentially exploit any known weaknesses of one or more services.

Turning off standalone services

To provide Internet services, such as web, e-mail, and FTP, your Linux system has to run server programs that listen to incoming TCP/IP network requests. Some of these servers start when your system boots, and they run all the time. Such servers are *standalone servers*. The web server and mail server are examples of standalone servers.

Another server, `xinetd`, starts other servers that are configured to work under `xinetd`. Some Linux systems use the `inetd` server instead of `xinetd` to start other servers.

Some servers can be configured to run standalone or under a super server such as `xinetd`. For example, the `vsftpd` FTP server can be configured to run standalone or to run under the control of `xinetd`.



In Debian, Ubuntu, and Xandros, use the `update-rc.d` command to turn off standalone servers and use the `invoke-rc.d` command to start or stop servers interactively. To get a clue about the available services, type **ls /etc/init.d** and look at all the script files designed to turn services on or off. You have to use these filenames when you want to turn a service on or off. For example, to turn off Samba service, type **update-rc.d -f samba remove**. If the service was already running, type **invoke-rc.d samba stop** to stop the service. You can use the `invoke-rc.d` command to stop any service in a similar manner.



In Fedora and SUSE, you can turn standalone servers on or off by using the `chkconfig` command. You can get the names of the service scripts by typing `ls /etc/init.d`. Then you can turn off a service (for example, Samba) by typing `chkconfig --del smb`. If the service was already running, type `/etc/init.d/smb stop` to stop the service. You can run scripts from the `/etc/init.d` directory with the `stop` argument to stop any service in a similar manner.

Configuring the Internet super server

In addition to standalone servers such as a web server or mail server, other servers — `inetd` or `xinetd` — have to be configured separately. These servers are *Internet super servers* because they can start other servers on demand.



Type `ps ax | grep inetd` to see which Internet super server — `inetd` or `xinetd` — your system runs.



Debian, Ubuntu, and Xandros use `inetd`, and Fedora and SUSE use `xinetd`.

The `inetd` server is configured through the `/etc/inetd.conf` file. You can disable a service by locating the appropriate line in that file and commenting it out by placing a pound sign (`#`) at the beginning of the line. After saving the configuration file, type `/etc/init.d/inetd restart` to restart the `inetd` server.

Configuring the `xinetd` server is a bit more complicated. The `xinetd` server reads a configuration file named `/etc/xinetd.conf` at startup. This file, in turn, refers to configuration files stored in the `/etc/xinetd.d` directory. The configuration files in `/etc/xinetd.d` tell `xinetd` which ports to listen to and which server to start for each port. Type `ls /etc/xinetd.d` to see a list of the files in the `/etc/xinetd.d` directory on your system. Each file represents a service that `xinetd` can start. To turn off any of these services, edit the file in a text editor and add a `disable = yes` line in the file. After you make any changes to the `xinetd` configuration files, you must restart the `xinetd` server; otherwise, the changes don't take effect. To restart the `xinetd` server, type `/etc/init.d/xinetd restart`. This command stops the `xinetd` server and then starts it again. When it restarts, it reads the configuration files, and the changes take effect.

Configuring TCP wrapper security

A security feature of both `inetd` and `xinetd` is their use of the TCP wrapper to start various services. The *TCP wrapper* is a block of code that provides an access-control facility for Internet services, acting like a protective package for your message. The TCP wrapper can start other services, such as FTP and TELNET; but before starting a service, it consults the `/etc/hosts.allow` file to see whether the host requesting the service is allowed

to use that service. If nothing appears in `/etc/hosts.allow` about that host, the TCP wrapper checks the `/etc/hosts.deny` file to see if it denies the service. If both files are empty, the TCP wrapper provides access to the requested service.

Here are the steps to follow to tighten access to the services that `inetd` or `xinetd` are configured to start:

1. Use a text editor to edit the `/etc/hosts.deny` file, adding the following line into that file:

```
ALL:ALL
```

This setting denies all hosts access to any Internet services on your system.

2. Edit the `/etc/hosts.allow` file and add to it the names of hosts that can access services on your system.

For example, to enable only hosts from the 192.168.1.0 network and the `localhost` (IP address 127.0.0.1) to access the services on your system, place the following line in the `/etc/hosts.allow` file:

```
ALL: 192.168.1.0/255.255.255.0 127.0.0.1
```

3. If you want to permit a specific remote host access to a specific Internet service, use the following syntax for a line in `/etc/hosts.allow`:

```
server_program_name: hosts
```

Here `server_program_name` is the name of the server program, and `hosts` is a comma-separated list of the hosts that can access the service. You may also write `hosts` as a network address or an entire domain name, such as `.mycompany.com`.

Using Secure Shell (SSH) for Remote Logins

Linux comes with the *Open Secure Shell* (OpenSSH) software, a suite of programs that provides a secure replacement for the Berkeley `r` commands: `rlogin` (remote login), `rsh` (remote shell), and `rcp` (remote copy). OpenSSH uses public key cryptography to authenticate users and to encrypt the communication between two hosts, so users can securely log in from remote systems and copy files securely.

This section briefly describes how to use the OpenSSH software in Linux. To find out more about OpenSSH and read the latest news about it, visit www.openssh.com or www.openssh.org.

The OpenSSH software is installed during Linux installation. Table 2-2 lists the main components of the OpenSSH software.

| <i>Component</i> | <i>Description</i> |
|-----------------------------------|---|
| <code>/usr/sbin/sshd</code> | This Secure Shell daemon must run on a host if you want users on remote systems to use the <code>ssh</code> client to log in securely. When a connection from the <code>ssh</code> client arrives, <code>sshd</code> performs authentication using public key cryptography and establishes an encrypted communication link with the <code>ssh</code> client. |
| <code>/usr/bin/ssh</code> | Users can run this Secure Shell client to log in to a host that is running <code>sshd</code> . Users can also use <code>ssh</code> to execute a command on another host. |
| <code>/usr/bin/slogin</code> | This component is a symbolic link to <code>/usr/bin/ssh</code> . |
| <code>/usr/bin/scp</code> | This secure-copy program works like <code>rcp</code> but securely. The <code>scp</code> program uses <code>ssh</code> for data transfer and provides the same authentication and security as <code>ssh</code> . |
| <code>/usr/bin/ssh-keygen</code> | You use this program to generate the public and private key pairs you need for the public key cryptography used in OpenSSH. The <code>ssh-keygen</code> program can generate key pairs for both RSA and DSA (Digital Signature Algorithm) authentication. (RSA comes from the initial of the last name of Ron Rivest, Adi Shamir, and Leonard Adleman — the developers of the RSA algorithm.) |
| <code>/etc/ssh/sshd_config</code> | This configuration file for the <code>sshd</code> server specifies many parameters for <code>sshd</code> , including the port to listen to, the protocol to use, and the location of other files. (There are two versions of SSH protocols: SSH1 and SSH2, both supported by OpenSSH.) |
| <code>/etc/ssh/ssh_config</code> | This configuration file is for the <code>ssh</code> client. Each user can also have an <code>ssh</code> configuration file named <code>config</code> in the <code>.ssh</code> subdirectory of the user's home directory. |

OpenSSH uses public key encryption, in which the sender and receiver both have a pair of keys — a public key and a private key. The public keys are freely distributed, and each party knows the other's public key. The sender encrypts data by using the recipient's public key. Only the recipient's private key can then decrypt the data.

To use OpenSSH, you first need to start the `sshd` server and then generate the host keys. Here's how:

- ◆ If you want to support SSH-based remote logins on a host, start the `sshd` server on your system. Type `ps ax | grep sshd` to see if the server is already running. If not, log in as `root` and turn on the SSH service.
- ◆ Generate the host keys with the following command:

```
ssh-keygen -d -f /etc/ssh/ssh_host_key -N ''
```

The `-d` flag causes the `ssh-keygen` program to generate DSA keys, which the SSH2 protocol uses. If you see a message saying that the file `/etc/ssh/ssh_host_key` already exists, it means that the key pairs were generated during Linux installation. You can use the existing file without having to regenerate the keys.

A user who wants to log in using SSH can simply use the `ssh` command. For example:

```
ssh 192.168.0.4 -l kdulaney
```

where `192.168.0.4` is the IP address of the other Linux system. SSH then displays a message:

```
The authenticity of host '192.168.0.4 (192.168.0.4)' can't be established.
RSA key fingerprint is 7b:79:f2:dd:8c:54:00:a6:94:ec:fa:8e:7f:c9:ad:66.
Are you sure you want to continue connecting (yes/no)?
```

Type **yes** and press Enter. SSH then adds the host to its list of known hosts and prompts you for a password on the other Linux system:

```
kdulaney@192.168.0.4's password:
```

After entering the password, you have a secure login session with that system. You can also log in to this account with the following equivalent command:

```
ssh kdulaney@192.168.0.4
```

If you simply want to copy a file securely from another system on the LAN (identified by its IP address, `192.168.0.4`), you can use `scp` like this:

```
scp 192.168.0.4:/etc/X11/xorg.conf
```

This command prompts for a password and securely copies the `/etc/X11/xorg.conf` file from the `192.168.0.4` host to the system from which the `scp` command was typed, as follows:

```
kdulaney@192.168.0.4's password: (type the password.)
xorg.conf 100% 2814 2.8KB/s 00:00
```

Setting Up Simple Firewalls

A *firewall* is a network device or host with two or more network interfaces — one connected to the protected internal network and the other connected to unprotected networks, such as the Internet. The firewall controls access to and from the protected internal network.

If you connect an internal network directly to the Internet, you have to make sure that every system on the internal network is properly secured — which can be nearly impossible because a single careless user can render the entire internal network vulnerable. A firewall is a single point of connection to the Internet: You can direct all your efforts toward making that firewall system a daunting barrier to unauthorized external users. Essentially, a firewall is like a protective fence that keeps unwanted external data and software out and sensitive internal data and software in. (See Figure 2-3.)

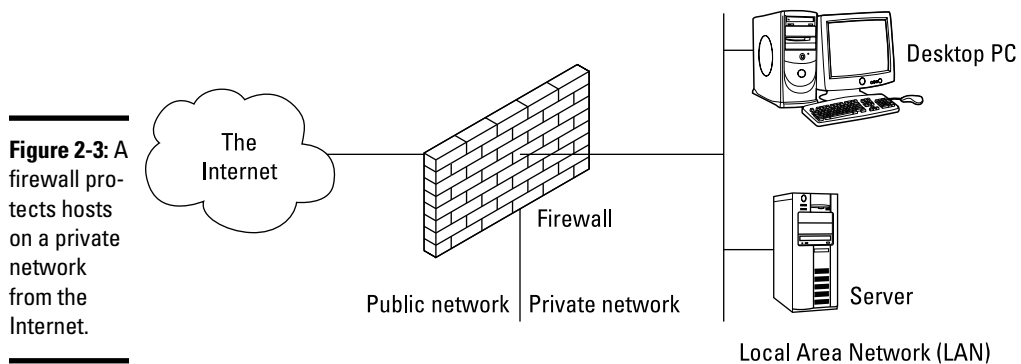

The firewall runs software that examines the network packets arriving at its network interfaces, and then takes appropriate action based on a set of rules. The idea is to define these rules so they allow only authorized network traffic to flow between the two interfaces. Configuring the firewall involves setting up the rules properly. A configuration strategy is to reject all network traffic and then enable only a limited set of network packets to go through the firewall. The authorized network traffic would include the connections necessary to enable internal users to do things such as visit websites and receive electronic mail.

To be useful, a firewall has the following general characteristics:

- ◆ It must control the flow of packets between the Internet and the internal network.
- ◆ It must *not* provide dynamic routing because dynamic routing tables are subject to route *spoofing* — the use of fake routes by intruders. Instead, the firewall uses static routing tables (which you can set up with the `route` command on Linux systems).

- ◆ It must not allow any external user to log in as `root`. That way, even if the firewall system is compromised, the intruder is blocked from using `root` privileges from a remote login.
- ◆ It must be kept in a physically secure location.
- ◆ It must distinguish between packets that come from the Internet and packets that come from the internal protected network. This feature allows the firewall to reject packets that come from the Internet but have the IP address of a trusted system on the internal network.
- ◆ It acts as the SMTP mail gateway for the internal network. Set up the `sendmail` software so that all outgoing mail appears to come from the firewall system.
- ◆ Its user accounts are limited to a few user accounts for those internal users who need access to external systems. External users who need access to the internal network should use SSH for remote login (see “Using Secure Shell (SSH) for Remote Logins,” earlier in this chapter).
- ◆ It keeps a log of all system activities, such as successful and unsuccessful login attempts.
- ◆ It provides DNS name-lookup service to the outside world to resolve any hostnames that are known to the outside world.
- ◆ It provides good performance so that it doesn’t hinder the internal users’ access to specific Internet services (such as HTTP and FTP).

A firewall can take many different forms. Here are three common forms of a firewall:

- ◆ **Packet filter firewall:** This simple firewall uses a router capable of filtering (blocking or allowing) packets according to a number of their characteristics, including the source and destination IP addresses, the network protocol (TCP or UDP), and the source and destination port numbers. Packet filter firewalls are usually placed at the outermost boundary with an untrusted network, and they form the first line of defense. An example of a packet filter firewall is a network router that employs filter rules to screen network traffic.

Packet filter firewalls are fast and flexible, but they can’t prevent attacks that exploit application-specific vulnerabilities or functions. They can log only a minimal amount of information, such as source IP address, destination IP address, and traffic type. Also, they’re vulnerable to attacks and exploits that take advantage of flaws within the TCP/IP protocol, such as IP address spoofing, which involves altering the address information in network packets to make them appear to come from a trusted IP address.

- ◆ **Stateful inspection firewall:** This type of firewall keeps track of the network connections that network applications are using. When an application on an internal system uses a network connection to create a session with a remote system, a port is also opened on the internal system. This port receives network traffic from the remote system. For successful

connections, packet filter firewalls must permit incoming packets from the remote system. Opening up many ports to incoming traffic creates a risk of intrusion by unauthorized users who abuse the expected conventions of network protocols such as TCP. Stateful inspection firewalls solve this problem by creating a table of outbound network connections, along with each session's corresponding internal port. This *state table* is then used to validate any inbound packets. This stateful inspection is more secure than a packet filter because it tracks internal ports individually rather than opening all internal ports for external access.

- ◆ **Application-proxy gateway firewall:** This firewall acts as an intermediary between internal applications that attempt to communicate with external servers such as a web server. For example, a web proxy receives requests for external web pages from web browser clients running inside the firewall and relays them to the exterior web server as though the firewall was the requesting web client. The external web server responds to the firewall, and the firewall forwards the response to the inside client as though the firewall was the web server. No direct network connection is ever made from the inside client host to the external web server.

Application-proxy gateway firewalls have some advantages over packet filter firewalls and stateful inspection firewalls. First, application-proxy gateway firewalls examine the entire network packet rather than only the network addresses and ports. This enables these firewalls to provide more extensive logging capabilities than packet filters or stateful inspection firewalls. Another advantage is that application-proxy gateway firewalls can authenticate users directly, whereas packet filter firewalls and stateful inspection firewalls normally authenticate users on the basis of the IP address of the system (that is, source, destination, and protocol type). Given that network addresses can be easily spoofed, the authentication capabilities of application-proxy gateway firewalls are superior to those found in packet filter and stateful inspection firewalls.

The advanced functionality of application-proxy gateway firewalls, however, results in some disadvantages when compared with packet filter or stateful inspection firewalls. First, because of the *full packet awareness* found in application-proxy gateways, the firewall is forced to spend significant time reading and interpreting each packet. Therefore application-proxy gateway firewalls are generally not well suited to high-bandwidth or real-time applications. To reduce the load on the firewall, a dedicated proxy server can be used to secure less time-sensitive services, such as e-mail and most web traffic. Another disadvantage is that application-proxy gateway firewalls are often limited in terms of support for new network applications and protocols. An individual application-specific proxy agent is required for each type of network traffic that needs to go through the firewall. Most vendors of application-proxy gateways provide generic proxy agents to support undefined network protocols or applications. However, those generic agents tend to negate many of the strengths of the application-proxy gateway architecture, and they simply allow traffic to *tunnel* through the firewall.

Most firewalls implement a combination of these firewall functionalities. For example, many vendors of packet filter firewalls or stateful inspection firewalls have also implemented basic application-proxy functionality to offset some of the weaknesses associated with their firewalls. In most cases, these vendors implement application proxies to provide better logging of network traffic and stronger user authentication. Nearly all major firewall vendors have introduced multiple firewall functions into their products in some manner.



In a large organization, you may also have to isolate smaller internal networks from the corporate network. You can set up such internal firewalls the same way that you set up Internet firewalls.

Using NAT

Network Address Translation (NAT) is an effective tool that enables you to *hide* the network addresses of an internal network behind a firewall. In essence, NAT allows an organization to use private network addresses behind a firewall while maintaining the ability to connect to external systems through the firewall.

Here are the three methods for implementing NAT:

- ◆ **Static:** In static NAT, each internal system on the private network has a corresponding external, routable IP address associated with it. This particular technique is seldom used because unique IP addresses are in short supply.
- ◆ **Hiding:** With hiding NAT, all systems behind a firewall share the same external, routable IP address, while the internal systems use private IP addresses. Thus, with a hiding NAT, a number of systems behind a firewall still appear to be a single system.
- ◆ **Port address translation:** With port address translation, you can place hosts behind a firewall system and still make them selectively accessible to external users.

In terms of strengths and weaknesses, each type of NAT — static, hiding, or port address translation — is applicable in certain situations; the variable is the amount of design flexibility offered by each type. Static NAT offers the most flexibility, but it's not always practical because of the shortage of IP addresses. Hiding NAT technology is seldom used because port address translation offers additional features. Port address translation is often the most convenient and secure solution.

Enabling packet filtering on your Linux system

The Linux kernel has built-in packet filtering software in the form of something called `netfilter`. You use the `iptables` command to set up the rules for what happens to the packets based on the IP addresses in their header and the network connection type.

422 *Setting Up Simple Firewalls*



To find out more about `netfilter` and `iptables`, visit the documentation section of the `netfilter` website at www.netfilter.org/documentation.

The built-in packet filtering capability is handy when you don't have a dedicated firewall between your Linux system and the Internet. This is the case, for example, when you connect your Linux system to the Internet through a DSL or cable modem. Essentially, you can have a packet filtering firewall inside your Linux system, sitting between the kernel and the applications.

Using the security level configuration tool

Some Linux distributions, such as Fedora and SUSE, include GUI tools to turn on a packet filtering firewall.



In Fedora, you can turn on different levels of packet filtering through the graphical Firewall Configuration tool. To run the tool, log in as `root` and choose Activities then type in Firewall. The Firewall Configuration window appears (see Figure 2-4) along with an authentication window.

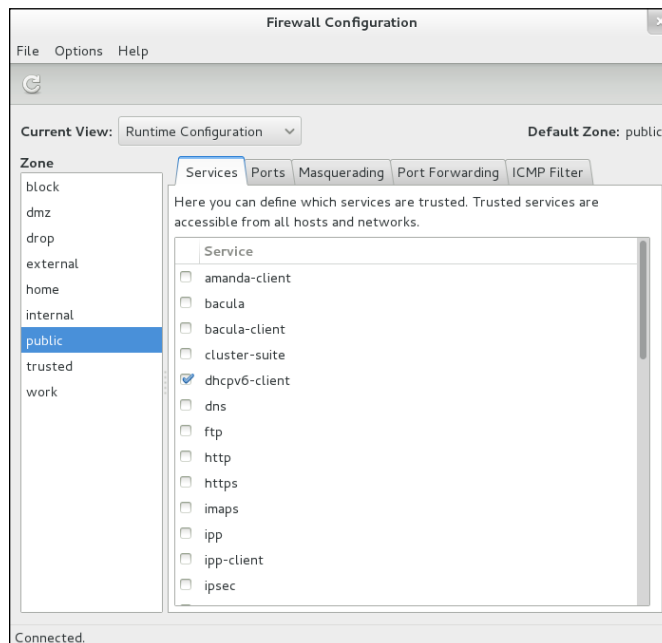

Figure 2-4: In Fedora, you can configure the firewall with this tool.

From the Firewall Configuration dialog box, you can select two predefined levels of simple firewalling (more precisely, packet filtering):

- ◆ **Disabled:** This option doesn't perform any filtering and allows all connections. (You can still turn off Internet services by not running the servers or disabling them in the `xinetd` configuration files.) This security

level is fine if your Linux system is inside a protected local area network or if you have a separate firewall device.

- ◆ **Enabled:** This option turns on packet filtering. You can then select the services that you want to allow and the network devices that you trust.

You can allow incoming packets meant for specific Internet services such as SSH, TELNET, and FTP. If you select a network interface such as `eth0` (the first Ethernet card) as trusted, all network traffic over that interface is allowed without any filtering.



In SUSE, to set up a firewall, choose Main Menu → System → YaST. In the YaST Control Center window that appears, click Security and Users on the left side of the window and then click Firewall on the right side. YaST opens a window that you can use to configure the firewall.

You can designate network interfaces (by device name, such as `eth0`, `ppp0`, and so on) to one of three zones: internal, external, or demilitarized zone. Then, for that zone, you can specify what services (such as HTTP, FTP, and SSH) are allowed. If you have two or more network interfaces and you use the Linux system as a gateway (a router), you can enable forwarding packets between network interfaces (a feature called *masquerading*). Figure 2-5 shows an example of this feature in the Firewall Configuration tool included with Fedora.

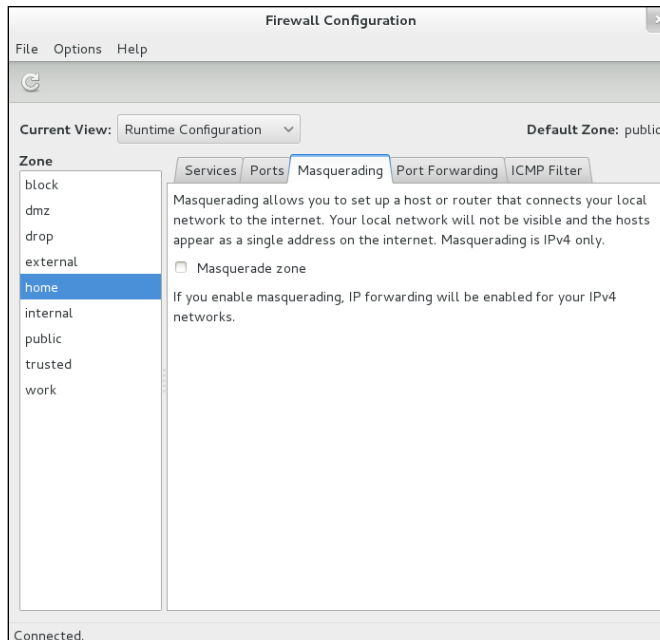

Figure 2-5:
In Fedora,
you can turn
on masquer-
ading with a
single click.

You can also turn on different levels of logging (for example, logging all dropped packets that attempt connection at specific ports). If you make changes to firewall settings, click the Startup category and click Save Settings and Restart Firewall Now.

Using the iptables command

The GUI firewall configuration tools use the `iptables` command to implement the firewall. If your Linux system doesn't have a GUI tool, you can use `iptables` directly to configure firewalling on your Linux system.

Using the `iptables` command is somewhat complex. The `iptables` command uses the concept of a *chain*, which is a sequence of rules. Each rule says what to do with a packet if the header contains certain information (such as the source or destination IP address). If a rule doesn't apply, `iptables` consults the next rule in the chain. By default, there are three chains:

- ◆ **INPUT chain:** The first set of rules against which packets are tested. The packets continue to the next chain only if the `INPUT` chain doesn't specify `DROP` or `REJECT`.
- ◆ **FORWARD chain:** Contains the rules that apply to packets attempting to pass through this system to another system (when you use your Linux system as a router between your LAN and the Internet, for example).
- ◆ **OUTPUT chain:** Includes the rules applied to packets before they are sent out (either to another network or to an application).

When an incoming packet arrives, the kernel uses `iptables` to make a routing decision based on the destination IP address of the packet. If the packet is for this server, the kernel passes the packet to the `INPUT` chain. If the packet satisfies all the rules in the `INPUT` chain, the packet is processed by local processes such as an Internet server that is listening for packets of this type.

If the kernel has IP forwarding enabled and the packet has a destination IP address of a different network, the kernel passes the packet to the `FORWARD` chain. If the packet satisfies the rules in the `FORWARD` chain, it's sent out to the other network. If the kernel doesn't have IP forwarding enabled and the packet's destination address isn't for this server, the packet is dropped.

If the local processing programs that receive the input packets want to send network packets out, those packets pass through the `OUTPUT` chain. If the `OUTPUT` chain accepts those packets, they're sent out to the specified destination network.

You can view the current chains, add rules to the existing chains, or create new chains of rules by using the `iptables` command. When you view the current chains, you can also save them to a file. For example, if you had

configured nothing else and your system has no firewall configured, typing **iptables -L** should show the following:

```
Chain INPUT (policy ACCEPT)
target prot opt source destination
Chain FORWARD (policy ACCEPT)
target prot opt source destination
Chain OUTPUT (policy ACCEPT)
target prot opt source destination
```

In this case, all three chains — INPUT, FORWARD, and OUTPUT — show the same ACCEPT policy, which means everything is wide open.

If you're setting up a packet filter, the first thing you do is specify the packets that you want to accept. For example, to accept packets from the 192.168.0.0 network address, add the following rule to the INPUT chain:

```
iptables -A INPUT -s 192.168.0.0/24 -j ACCEPT
```

Now add a rule to drop everything except local loopback (the `lo` network interface) traffic and stop all forwarding with the following commands:

```
iptables -A INPUT -i ! lo -j REJECT
iptables -A FORWARD -j REJECT
```

The first `iptables` command, for example, appends to the INPUT chain (`-A INPUT`) the rule that if the packet does not come from the `lo` interface (`-i ! lo`), `iptables` rejects the packet (`-j REJECT`).

Before rejecting all other packets, you may also add more rules to each INPUT chain to allow specific packets in. You can select packets to accept or reject based on many parameters, such as IP addresses, protocol types (TCP, UDP), network interface, and port numbers.

You can do all sorts of specialized packet filtering with `iptables`. For example, suppose you set up a web server and want to accept packets meant for only HTTP (port 80) and Secure Shell (SSH) services. The Secure Shell service (port 22) is for you to securely log in and administer the server. Suppose the server's IP address is 192.168.0.10. Here is how you might set up the rules for this server:

```
iptables -P INPUT DROP
iptables -A INPUT -s 0/0 -d 192.168.0.10 -p tcp --dport 80 -j ACCEPT
iptables -A INPUT -s 0/0 -d 192.168.0.10 -p tcp --dport 22 -j ACCEPT
```

In this case, the first rule sets up the default policy of the INPUT chain to DROP, which means that if none of the specific rules match, the packet will be dropped. The next two rules say that packets addressed to 192.168.0.10 and meant for ports 80 and 22 are accepted.



Don't type `iptables` commands from a remote login session. A rule that begins denying packets from all addresses can also stop what you type from reaching the system; if that happens, you may have no way of accessing the system over the network. To avoid unpleasant surprises, always type `iptables` rules at the console — the keyboard and monitor connected directly to your Linux PC that is running the packet filter. If you want to delete all filtering rules in a hurry, type **`iptables -F`** to flush them. To change the default policy for the INPUT chain to `ACCEPT`, type **`iptables -t filter -P INPUT ACCEPT`**. This causes `iptables` to accept all incoming packets by default.



Not every `iptables` command is discussed in this section. You can type **`man iptables`** to read a summary of the commands. You can also read about `netfilter` and `iptables` at www.iptables.org.

After you define the rules by using the `iptables` command, they're in memory and are gone when you reboot the system. Use the `iptables-save` command to store the rules in a file. For example, you can save the rules in a file named `iptables.rules` by using the following command:

```
iptables-save > iptables.rules
```

Here's a listing of the `iptables.rules` file generated on a Fedora system:

```
# Generated by iptables-save v1.3.0 on Sun Dec 28 16:10:12 2014
*filter
:FORWARD ACCEPT [0:0]
:INPUT ACCEPT [0:0]
:OUTPUT ACCEPT [6:636]
-A FORWARD -j REJECT --reject-with icmp-port-unreachable
-A INPUT -s 192.168.0.0/255.255.255.0 -j ACCEPT
-A INPUT -i ! lo -j REJECT --reject-with icmp-port-unreachable
COMMIT
# Completed on Sun Dec 28 16:10:12 2014
```

These rules correspond to the following `iptables` commands used to configure the filter:

```
iptables -A INPUT -s 192.168.0.0/24 -j ACCEPT
iptables -A INPUT -i ! lo -j REJECT
iptables -A FORWARD -j REJECT
```

If you want to load these saved rules into `iptables`, use the following command:

```
iptables-restore < iptables.rules
```

Security Files to Be Aware Of

Table 2-3 lists eleven files, or directories, that security administrators should be aware of and able to explain the purpose of.

| Table 2-3 Key Security Files | |
|-------------------------------------|---|
| <i>File</i> | <i>Description</i> |
| <code>/etc/nologin</code> | If this file exists, it denies login to all users except <code>root</code> . This can be handy when maintenance needs to be done and users need to stay off the system for a period of time. Removing the file restores login capability for all users. The file can be created as a text file with any editor, or you can often use the <code>nologin</code> command to create it. |
| <code>/etc/passwd</code> | This file holds much of the user account information and is addressed heavily in this chapter. |
| <code>/etc/shadow</code> | When shadowing is turned on – which it almost always is – then password values (hashes) are stored in this file (which is more secure) as opposed to in <code>/etc/passwd</code> . |
| <code>/etc/xinetd.d/*</code> | This directory can be used to store configuration files used by <code>xinetd</code> , the server daemon. |
| <code>/etc/xinetd.conf</code> | This is the main configuration file used by <code>xinetd</code> , the server daemon. |
| <code>/etcrcxinetd.d/*</code> | This directory can be used to store configuration files used by <code>inetd</code> , the Internet daemon. In almost all distributions, <code>inetd</code> has been replaced by <code>xinetd</code> . |
| <code>/etcrc/inetd.conf</code> | This is the main configuration file used by <code>inetd</code> , the Internet daemon. |
| <code>/etcrc/inittab</code> | This is the initial startup (initialization) table used to identify what starts and stops as the system is booted and changes run states. |
| <code>/etcrc/init.d/*</code> | This directory can hold configuration files that are used during the change of run states/level and referenced by the <code>inittab</code> file. |
| <code>/etcrc/hosts.allow</code> | If this file exists, then it specifically lists the hosts that are allowed to network with this one. If the file does not exist, then the default is that all hosts are allowed to network with this one. |
| <code>/etcrc/hosts.deny</code> | If this file exists, then it specifically lists the hosts that are not allowed to network with this one. If the file does not exist, then the default is that all hosts are allowed to network with this one. |
| | The three possibilities are that there is an <code>allow</code> file identifying only hosts that can, a <code>deny</code> file that identifies only hosts that cannot, or neither file – in which case all other hosts are allowed to network with this one. |

Chapter 3: Computer Security Audits and Vulnerability Testing Types

In This Chapter

Understanding computer security audits

- ✓ Learning a security test methodology
- ✓ Reviewing host and network security
- ✓ Appreciating vulnerability testing
- ✓ Exploring different security testing tools

When you see the term *audit*, the odds are good you think of the kind involving taxes. In actuality, many types of audits exist, and one of them is a *computer security audit*. The purpose of a computer security audit, in its simplest form, is to test your system and network security. For larger organizations, an independent auditor (much like with the auditing of financial statements) can do the security audit. If you have only a few Linux systems or a small network, you can do the security audit as a self-assessment, just to figure out if you're doing everything okay.

This chapter explains how to perform computer security audits and shows you a number of free tools and resources to help you test your system's security.

Understanding Security Audits

An *audit* is simply an independent assessment of whatever it is you're auditing. So a *computer security audit* is an independent assessment of computer security. If someone conducts a computer security audit of your organization, he or she focuses typically on two areas:

- ◆ **Independent verification** of whether your organization complies with its existing policies and procedures for computer security. This part is the nontechnical aspect of the security audit.
- ◆ **Independent testing** of how effective your security controls (any hardware and software mechanisms you use to secure the system) are. This part is the technical aspect of the security audit.

Why do you need security audits? For the same reason you need financial audits — mainly to verify that everything is being done the way it's supposed to be done. For public as well as private organizations, management may want to have independent security audits done so as to assure themselves that their security is A-OK. Irrespective of your organization's size, you can always perform security audits on your own, either to prepare for independent security audits or simply to know that you're doing everything correctly.

No matter whether you have independent security audits or a self-assessment, here are some of the benefits you get from security audits:

- ◆ Periodic risk assessments that consider internal and external threats to systems and data
- ◆ Periodic testing of the effectiveness of security policies, security controls, and techniques
- ◆ Identification of any significant deficiencies in your system's security (so you know what to fix)
- ◆ In the case of self-assessments, preparation for any annual independent security testing that your organization might have to face

Nontechnical aspects of security audits

The nontechnical side of computer security audits focuses on your organization-wide security framework. The audit examines how well the organization has set up and implemented the policies, plans, and procedures for computer security. Here's a list of some items to be verified:

- ◆ Risks are periodically assessed.
- ◆ An entity-wide security program plan is in place.
- ◆ A security program-management structure is in place.
- ◆ Computer security responsibilities are clearly assigned.
- ◆ Effective security-related personnel policies are in place.
- ◆ The security program's effectiveness is monitored and changes are made when needed.

As you may expect, the nontechnical aspects of the security audit involve reviewing documents and interviewing appropriate individuals to find out how the organization manages computer security. For a small organization or a home PC, expecting plans and procedures in documents is ridiculous. In those cases, simply make sure that you have some technical controls in place to secure your system and your network connection.

Technical aspects of security audits

The technical side of computer security audits focuses on testing the technical controls that secure your hosts and network. The testing involves determining

- ◆ **How well the host is secured.** Are all operating system patches applied? Are the file permissions set correctly? Are user accounts protected? Are file changes monitored? Are log files monitored? And so on.
- ◆ **How well the network is secured.** Are unnecessary Internet services turned off? Is a firewall installed? Are remote logins secured with tools such as SSH? Are TCP wrapper access controls used? And so on.

Typically, security experts use automated tools to perform these two security reviews, for individual hosts and for the entire network.

Implementing a Security Test Methodology

A key element of a computer security audit is a security test that checks the technical mechanisms used to secure a host and the network. The security-test methodology follows these high-level steps:

1. Take stock of the organization's networks, hosts, network devices (routers, switches, firewalls, and so on), and Internet connection.
2. If there are many hosts and network connections, determine which are the important hosts and network devices that need to be tested. The importance of a host depends on the kinds of applications it runs. For example, a host that runs the corporate database would be more important than the hosts that serve as desktop systems.
3. Test the hosts individually. Typically, this step involves logging in as a system administrator and checking various aspects of host security, from passwords to system log files.
4. Test the network. This step is usually performed by attempting to break through the network defenses from another system on the Internet. If there's a firewall, the testing checks that the firewall is indeed configured correctly.
5. Analyze the test results of both host and network tests to determine vulnerabilities and risks.

Each of the two types of testing — host and network — focuses on three areas of overall computer security:

- ◆ **Prevention:** Includes the mechanisms (nontechnical and technical) that help prevent attacks on the system and the network.

- ◆ **Detection:** Refers to techniques such as monitoring log files, checking file integrity, and using *intrusion detection* systems that can detect when someone is about to break into (or has already broken into) your system.
- ◆ **Response:** Includes the steps for tasks such as reporting an incident to authorities and restoring important files from backup after a computer security incident occurs.

For host and network security, each of these areas has some overlaps. For example, prevention mechanisms for host security (such as good passwords or file permissions) can also provide network security. Nevertheless, thinking in terms of the three areas — prevention, detection, and response — does help.

Some common computer vulnerabilities

Before you can think of prevention, however, you have to know the types of problems you're trying to prevent — the common security vulnerabilities. The prevention and detection steps typically depend on the specific vulnerabilities. Basically, the idea is to check whether a host or a network has the vulnerabilities that crackers exploit.

Online resources on computer vulnerabilities

Several online resources identify and categorize computer security vulnerabilities:

- ◆ **SANS Institute** publishes a list of the top 20 most critical Internet security vulnerabilities — the Top Cyber Security Risks index — at www.sans.org/top20.
- ◆ **CVE** (Common Vulnerabilities and Exposures) is a list of standardized names of vulnerabilities. For more information on CVE, see <http://cve.mitre.org>. Using the CVE name to describe vulnerabilities is common practice.
- ◆ **National Vulnerability Database (NVD)** is a searchable index of information on computer vulnerabilities, published by the National Institute of Standards and Technology (NIST), a United States government agency. NVD is online at <http://nvd.nist.gov>.

Typical computer vulnerabilities

The SANS Internet security vulnerabilities list includes several types of vulnerabilities, such as Windows, cross-platform, and Unix. Of these, Unix and cross-platform vulnerabilities are relevant to Linux.

Table 3-1 summarizes some common Unix and cross-platform vulnerabilities that apply to Linux.

Table 3-1 Some Common Vulnerabilities to Unix Systems

| <i>Vulnerability Type</i> | <i>Description</i> |
|-------------------------------------|--|
| BIND DNS | Berkeley Internet Name Domain (BIND) is a package that implements Domain Name System (DNS), the Internet's name service that translates a name to an IP address. Some versions of BIND have vulnerabilities. |
| Apache Web Server | Some Apache Web Server modules (such as <code>mod_ssl</code>) have known vulnerabilities. Any vulnerability in Common Gateway Interface (CGI) programs used with web servers to process interactive web pages can provide attackers a way to gain access to a system. |
| Authentication | User accounts often have no passwords or have weak passwords that are easily cracked by password-cracking programs. |
| CVS, Subversion | Concurrent Versions System (CVS) is a popular source-code control system used in Linux systems. Subversion is another version control system for Linux that is becoming popular. These version control systems have vulnerabilities that can enable an attacker to execute arbitrary code on the system. |
| <code>sendmail</code> | <code>sendmail</code> is a complex program used to transport mail messages from one system to another, and some versions of <code>sendmail</code> have vulnerabilities. |
| SNMP | Simple Network Management Protocol (SNMP) is used to remotely monitor and administer various network-connected systems ranging from routers to computers. SNMP lacks good access control, so an attacker may be able to reconfigure or shut down your system if it is running SNMP. |
| Open Secure Sockets Layer (OpenSSL) | Many applications, such as Apache Web Server, use OpenSSL to provide cryptographic security for a network connection. Unfortunately, some versions of OpenSSL have known vulnerabilities that could be exploited. |

(continued)

Table 3-1 (continued)

| <i>Vulnerability Type</i> | <i>Description</i> |
|---|---|
| Network File System (NFS) and Network Information Service (NIS) | Both NFS and NIS have many security problems (for example, buffer overflow, potential for denial-of-service attacks, and weak authentication). Also, NFS and NIS are often misconfigured, which could allow local and remote users to exploit the security holes. |
| Databases | Databases such as MySQL and PostgreSQL are complex applications and can be difficult to correctly configure and secure. These databases have many features that can be misused or exploited to compromise the confidentiality, availability, and integrity of data. |
| Linux kernel | The Linux kernel is susceptible to many vulnerabilities, such as denial of service, execution of arbitrary code, and root-level access to the system. |

Host-security review

When reviewing host security, focus on assessing the security mechanisms in each of the following areas:

- ◆ **Prevention:** Install operating system updates, secure passwords, improve file permissions, set up a password for a boot loader, and use encryption.
- ◆ **Detection:** Capture log messages and check file integrity with Tripwire (a tool that can detect changes to system files).
- ◆ **Response:** Make routine backups and develop incident response procedures.

The following sections review a few of these host-security mechanisms.

Operating system updates

Linux distributions release updates soon. When security vulnerabilities are found, Linux distributions release an update to fix the problem. Many distributions offer online updates that you can enable and use to keep your system up to date. The details of updating the operating system depend on the distribution. (See Book V, Chapter 4 for information on how to update Linux online.)

File permissions

Protect important system files with appropriate file ownerships and file permissions. The key procedures in assigning file-system ownerships and permissions are as follows:

- ◆ Figure out which files contain sensitive information and why. Some files may contain sensitive data related to your work or business, whereas many other files are sensitive because they control the Linux system configuration.
- ◆ Maintain a current list of authorized users and what they are authorized to do on the system.
- ◆ Set up passwords, groups, file ownerships, and file permissions to allow only authorized users to access the files.

Table 3-2 lists some important system files in Linux, showing the typical numeric permission setting for each file (this may differ slightly, depending on the distribution). See Chapter 2 of this minibook for more on numeric permission settings.

| <i>File Pathname</i> | <i>Permission</i> | <i>Description</i> |
|----------------------|-------------------|--|
| /boot/grub/menu.lst | 600 | GRUB boot loader menu file |
| /etc/cron.allow | 400 | List of users permitted to use <code>cron</code> to submit periodic jobs |
| /etc/cron.deny | 400 | List of users who can't use <code>cron</code> to submit periodic jobs |
| /etc/crontab | 644 | System-wide periodic jobs |
| /etc/hosts.allow | 644 | List of hosts allowed to use Internet services that are started using TCP wrappers |
| /etc/hosts.deny | 644 | List of hosts denied access to Internet services that are started using TCP wrappers |
| /etc/logrotate.conf | 644 | File that controls how log files rotate |
| /etc/pam.d | 755 | Directory with configuration files for pluggable authentication modules (PAMs) |
| /etc/passwd | 644 | Old-style password file with user account information but not the passwords |

(continued)

Table 3-2 (continued)

| <i>File Pathname</i> | <i>Permission</i> | <i>Description</i> |
|----------------------|-------------------|--|
| /etc/rc.d | 755 | Directory with system-startup scripts |
| /etc/securetty | 600 | TTY interfaces (terminals) from which root can log in |
| /etc/security | 755 | Policy files that control system access |
| /etc/shadow | 400 | File with encrypted passwords and password expiration information |
| /etc/shutdown.allow | 400 | Users who can shut down or reboot by pressing Ctrl+Alt+Delete |
| /etc/ssh | 755 | Directory with configuration files for the Secure Shell (SSH) |
| /etc/sysconfig | 755 | System configuration files |
| /etc/sysctl.conf | 644 | Kernel configuration parameters |
| /etc/syslog.conf | 644 | Configuration file for the syslogd server that logs messages |
| /etc/udev/udev.conf | 644 | Configuration file for udev — the program that provides the capability to dynamically name hot-pluggable devices and create the device files in the /dev directory |
| /etc/vsftpd | 600 | Configuration file for the Very Secure FTP server |
| /etc/vsftpd.ftputers | 600 | List of users who are not allowed to use FTP to transfer files |
| /etc/xinetd.conf | 644 | Configuration file for the xinetd server |
| /etc/xinetd.d | 755 | Directory containing configuration files for specific services that the xinetd server can start |
| /var/log | 755 | Directory with all log files |
| /var/log/lastlog | 644 | Information about all previous logins |
| /var/log/messages | 644 | Main system message log file |
| /var/log/wtmp | 664 | Information about current logins |

Another important check is to look for executable program files that have the `setuid` permission. If a program has `setuid` permission and is owned by `root`, the program runs with `root` privileges, no matter who actually runs the program. You can find all `setuid` programs with the following `find` command:

```
find / -perm +4000 -print
```

You may want to save the output in a file (just append `> filename` to the command) and then examine the file for any unusual `setuid` programs. For example, a `setuid` program in a user's home directory is unusual.

Password security

Verify that the password, group, and shadow password files are protected. In particular, the shadow password file has to be write-protected and readable only by `root`. The filenames and their recommended permissions are shown in Table 3-3.

Table 3-3 Ownership and Permission of Password Files

| <i>File Pathname</i> | <i>Ownership</i> | <i>Permission</i> |
|----------------------|------------------|-------------------|
| /etc/group | root.root | 644 |
| /etc/passwd | root.root | 644 |
| /etc/shadow | root.root | 400 |

Incident response

Incident response is the policy that answers the question of what to do if something unusual does happen to the system. The policy tells you how to proceed if someone breaks into your system.

Your response to an incident depends on how you use your system and how important it is to you or your business. For a comprehensive incident response, remember these key points:

- ◆ Figure out how critical and important your computer and network are — and identify who or what resources can help you protect your system.
- ◆ Take steps to prevent and minimize potential damage and interruption.
- ◆ Develop and document a comprehensive contingency plan.
- ◆ Periodically test the contingency plan and revise the procedures as appropriate.

Network-security review

A *network-security review* focuses on assessing the security mechanisms in each of the following areas:

- ◆ **Prevention:** Set up a firewall, enable packet filtering, disable unnecessary `inetd` or `xinetd` services, turn off unneeded Internet services, use TCP wrappers for access control, and use SSH for secure remote logins.
- ◆ **Detection:** Use network intrusion detection and capture system logs.
- ◆ **Response:** Develop incident response procedures.

Some key steps in assessing the network security are described in the following three subsections.

Services started by `inetd` or `xinetd`

Depending on your distribution, the `inetd` or `xinetd` server may be configured to start some Internet services such as TELNET and FTP. The decision to turn on some of these services depends on such factors as how the system connects to the Internet and how the system is being used. You can usually turn off most `inetd` and `xinetd` services by commenting out the line — just place a pound sign (#) at the beginning of the line.

If you are using `xinetd`, it is possible to see which services are turned off by checking the configuration files in the `/etc/xinetd.d` directory for all the configuration files that have a `disable = yes` line. (The line doesn't count if it's commented out, which is indicated by a # character at the beginning of the line.) You can add a `disable = yes` line to the configuration file of any service that you want to turn off.

Also check the following files for any access controls used with the `inetd` or `xinetd` services:

- ◆ `/etc/hosts.allow` lists hosts allowed to access specific services.
- ◆ `/etc/hosts.deny` lists hosts denied access to services.

Standalone services

Many services, such as `apache` or `httpd` (web server) and `sendmail` (mail server), start automatically at boot time, assuming they're configured to start that way.

In some distributions, you can use the `chkconfig` command to check which of these standalone servers are set to start at various run levels. (See Book V, Chapter 1 for more about run levels.) Typically, most systems start up at run level 3 (for text login) or 5 (for graphical login). Therefore, what matters is the setting for the servers in levels 3 and 5. To view the list of servers, type **`chkconfig --list`** | **more**. When you do a self-assessment of your network

security and find that some servers shouldn't be running, you can turn them off for run levels 3 and 5 by typing **chkconfig --level 35 servicename off**, where *servicename* is the name of the service you want to turn off.

In some distributions, you can use a GUI tool to see which services are enabled and running at any run level. With YaST, for example, click System on the left side of the window, and then click Runlevel Editor on the right side of the window.

When you audit network security, make a note of all the servers that are turned on — and then try to determine whether they should really *be* on, according to what you know about the system. The decision to turn on a particular service depends on how your system is used (for example, as a web server or as a desktop system) and how it's connected to the Internet (say, through a firewall or directly).

Penetration test

A penetration test is the best way to tell what services are really running on a Linux system. *Penetration testing* involves trying to get access to your system from an attacker's perspective. Typically, you perform this test from a system on the Internet and try to break in or, at minimum, get access to services running on your Linux system.

One aspect of penetration testing is to see what ports are open on your Linux system. The *port number* is simply a number that identifies TCP/IP network connections to the system. The attempt to connect to a port succeeds only if a server is running, or "listening," on that port. A port is considered to be open if a server responds when a connection request for that port arrives.

The first step in penetration testing is to perform a port scan. The term *port scan* describes the automated process of trying to connect to each port number to see whether a valid response comes back. Many available automated tools can perform port scanning — you can install and use a popular port-scanning tool called `nmap` (described later in this chapter).

After performing a port scan, you know which ports are open and could be exploited. Not all servers have security problems, but many servers have well-known vulnerabilities. An open port provides a cracker a way to attack your system through one of the servers. In fact, you can use automated tools called *vulnerability scanners* to identify vulnerabilities that exist in your system (some vulnerability scanners are described in the following sections). Whether your Linux system is connected to the Internet directly (through DSL or cable modem) or through a firewall, use the port-scanning and vulnerability-scanning tools to figure out whether you have any holes in your defenses.

Vulnerability Testing Types

The number-one purpose of penetration testing is to identify vulnerabilities. When viewing such a test from this angle, it is important to understand that there are three ways of approaching it: *black*, *white*, or *gray*. These three approaches differ in the amount of information you assume you have in the beginning; you can use the color with almost any other word: *black box* versus *white box* if it is a piece of software doing the testing; *black hat* versus *white hat* if it is an individual doing the testing; and so on. The following discussion focuses on the individual and uses *box* as the preferred noun.

- ◆ With *black-box testing*, the tests assume no knowledge of the network and look for vulnerabilities that an outsider might stumble across, such as open ports and weak passwords.

Imagine that a bored miscreant came across your network at random and decided to bring it to its knees.

- ◆ With *white-box testing*, the test assumes that the attacker is a knowledgeable insider who's trying to break the system.

Imagine that you just fired a system administrator and they want to get back at you by crashing your network.

- ◆ Between these two extremes rests the realm of *gray-box testing*. Here the assumption is that an insider is behind the problem.

Imagine someone from shipping is angry about not getting the raise he or she thought was deserved, and so wants to make the company pay. The attacker doesn't have the knowledge an administrator would, but still knows more about the systems than a complete outsider would.

Exploring Security Testing Tools

Many automated tools are available to perform security testing. Some of these tools are meant for finding the open ports on every system in a range of IP addresses. Others look for the vulnerabilities associated with open ports. Yet other tools can capture (or *sniff*) those weaknesses and help you analyze them so that you can glean useful information about what's going on in your network.

You can browse a list of the top 100 security tools (based on an informal poll of nmap users) at <http://sectools.org>. Table 3-4 lists a number of these tools by category. A few of the freely available vulnerability scanners are described in the next few sections.

Table 3-4 Some Popular Computer-Security Testing Tools

| <i>Type</i> | <i>Names of Tools</i> |
|-----------------------------------|--|
| Port scanners | nmap, Strobe |
| Vulnerability scanners | Nessus Security Scanner, SAINT, SARA, Whisker (CGI scanner), ISS Internet Scanner, CyberCop Scanner, Vetescan, Retina Network Security Scanner |
| Network utilities | Netcat, hping2, Firewalk, Cheops, ntop, ping, ngrep, AirSnort (802.11 WEP encryption-cracking tool) |
| Host-security tools | Tripwire, Isof |
| Packet sniffers | tcpdump, Ethereal, dsniff, sniffit |
| Intrusion detection | Snort, Abacus portsentry, scanlogd, NFR, LIDSSystems (IDSs) |
| Password-checking tools | John the Ripper, LC4 |
| Log analysis and monitoring tools | logcolorise, tcpdstats, nlog, logcheck, LogWatch, Swatch |

nmap

nmap (short for *network mapper*) is a port-scanning tool. It can rapidly scan large networks and determine what hosts are available on the network, what services they offer, what operating system (and the operating system version) they run, what type of packet filters or firewalls they use, and dozens of other characteristics. You can read more about *nmap* at <http://nmap.org>.

If *nmap* is not already installed, you can easily install it on your distribution either with the command `apt-get install nmap` or through the software search facility of YaST (find *nmap*) or any distribution-specific interface you may have.

If you want to try out *nmap* to scan your local area network, type a command similar to the following (replace the IP address range with addresses appropriate for your network):

```
nmap -O -sS 192.168.0.4-8
```

Here's a typical output listing from that command:

```
Starting nmap 6.40 ( http://www.insecure.org/nmap/ ) at 2013-08-28 16:20 EDT
Interesting ports on 192.168.0.4:
(The 1659 ports scanned but not shown below are in state: closed)
PORT STATE SERVICE
21/tcp open ftp
```

```
22/tcp open ssh
111/tcp open rpcbind
631/tcp open ipp
MAC Address: 00:C0:49:63:78:3A (U.S. Robotics)
Device type: general purpose
Running: Linux 3.9.X|3.9.X|3.9.X
OS details: Linux 2.4.18 - 2.6.7
Uptime 9.919 days (since Thu Aug 18 18:18:15 2013)
. . . Lines deleted . . .
Nmap finished: 5 IP addresses (5 hosts up) scanned in 30.846 seconds
```

As you can see, nmap displays the names of the open ports and hazards a guess at the operating system name and version number.

For a very quick scan of your own machine, you can use the IP address of 127.0.0.1 (as shown in Figure 3-1); hopefully the scan will verify that the ports are closed.

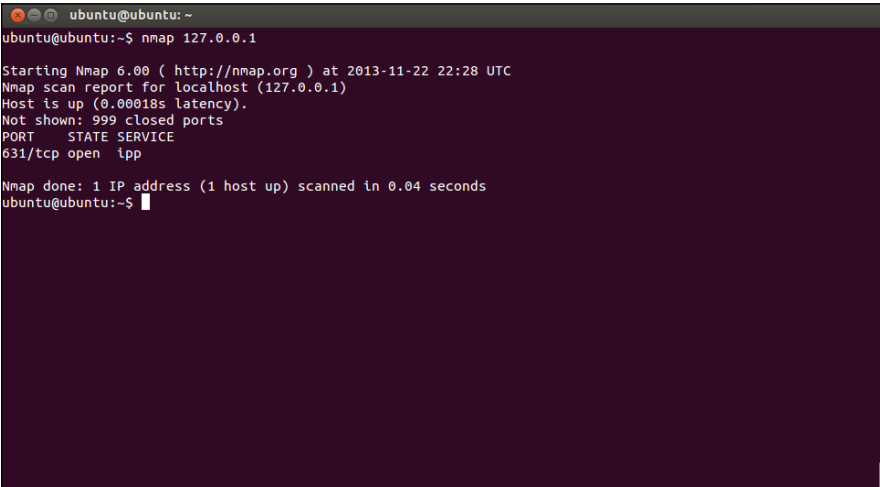

```
ubuntu@ubuntu: ~
ubuntu@ubuntu:~$ nmap 127.0.0.1
Starting Nmap 6.00 ( http://nmap.org ) at 2013-11-22 22:28 UTC
Nmap scan report for localhost (127.0.0.1)
Host is up (0.00018s latency).
Not shown: 999 closed ports
PORT      STATE SERVICE
631/tcp   open  ipp
Nmap done: 1 IP address (1 host up) scanned in 0.04 seconds
ubuntu@ubuntu:~$
```

Figure 3-1:
You can
view any
open ports
with nmap.

Book VII

Scripting

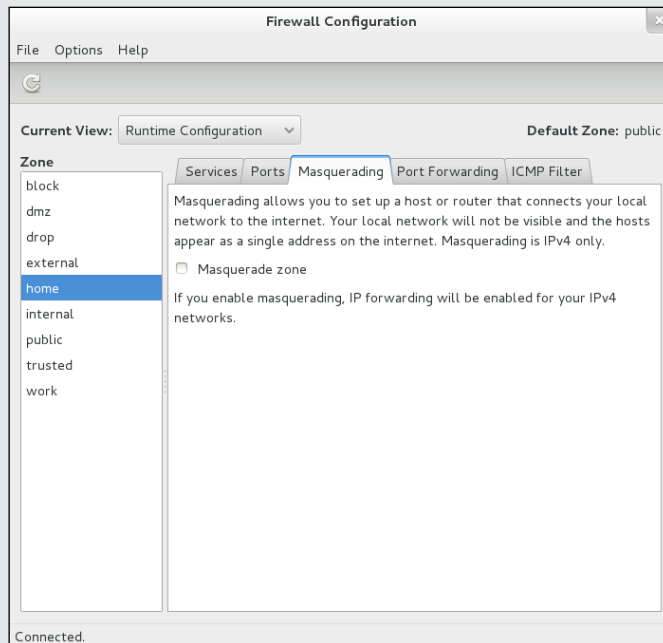

Visit www.dummies.com/extras/linuxaio for great Dummies content online.

Contents at a Glance

| | |
|---|------------|
| Chapter 1: Introductory Shell Scripting | 445 |
| Trying Out Simple Shell Scripts | 445 |
| Exploring the Basics of Shell Scripting | 447 |
| Chapter 2: Advanced Shell Scripting | 457 |
| Trying Out sed | 457 |
| Working with awk and sed | 459 |
| Final Notes on Shell Scripting | 463 |
| Chapter 3: Programming in Linux | 465 |
| An Overview of Programming | 465 |
| Exploring the Software-Development Tools in Linux | 467 |
| Understanding the Implications of GNU Licenses | 484 |

Chapter 1: Introductory Shell Scripting

In This Chapter

- ✓ Trying some simple shell scripts
- ✓ Discovering the basics of shell scripting
- ✓ Exploring bash's built-in commands

Linux gives you many small and specialized commands, along with the plumbing necessary to connect these commands. Take *plumbing* to mean the way in which one command's output can be used as a second command's input. `bash` (short for Bourne-Again Shell) — the default shell in most Linux systems — provides this plumbing in the form of I/O redirection and pipes. `bash` also includes features such as the `if` statement that you can use to run commands only when a specific condition is true, and the `for` statement that repeats commands a specified number of times. You can use these features of `bash` when writing programs called *shell scripts* — task-oriented collections of shell commands stored in a file.

This chapter shows you how to write simple shell scripts, which are used to automate various tasks. For example, when your Linux system boots, many shell scripts stored in various subdirectories in the `/etc` directory (for example, `/etc/init.d`) perform many initialization tasks.

Trying Out Simple Shell Scripts

If you're not a programmer, you may feel apprehensive about programming. But shell *scripting* (or programming) can be as simple as storing a few commands in a file. In fact, you can have a useful shell program that has a single command.

Shell scripts are popular among system administrators. If you are a system administrator, you can build a collection of custom shell scripts that help you automate tasks you perform often. If a hard drive seems to be getting full, for example, you may want to find all files that exceed some size (say, 1MB) and that have not been accessed in the past 30 days. In addition, you may want to send an e-mail message to all users who have large files, requesting that they archive and clean up those files. You can perform

all these tasks with a shell script. You might start with the following `find` command to identify large files:

```
find / -type f -atime +30 -size +1000k -exec ls -l {} \; > /tmp/largefiles
```

This command creates a file named `/tmp/largefiles`, which contains detailed information about old files taking up too much space. After you get a list of the files, you can use a few other Linux commands — such as `sort`, `cut`, and `sed` — to prepare and send mail messages to users who have large files to clean up. Instead of typing all these commands manually, place them in a file and create a shell script. That, in a nutshell, is the essence of shell scripts — to gather shell commands in a file so that you can easily perform repetitive system administration tasks.

`bash` scripts, just like most Linux commands, accept command-line options. Inside the script, you can refer to the options as `$1`, `$2`, and so on. The special name `$0` refers to the name of the script itself.

Here's a typical `bash` script that accepts arguments:

```
#!/bin/sh
echo "This script's name is: $0"
echo Argument 1: $1
echo Argument 2: $2
```

The first line runs the `/bin/sh` program, which subsequently processes the rest of the lines in the script. The name `/bin/sh` traditionally refers to the Bourne shell — the first Unix shell. In most Linux systems, `/bin/sh` is a symbolic link to `/bin/bash`, which is the executable program for `bash`.

Save this simple script in a file named `simple` and make that file executable with the following command:

```
chmod +x simple
```

Now run the script as follows:

```
./simple
```

It displays the following output:

```
This script's name is: ./simple
Argument 1:
Argument 2:
```

The first line shows the script's name. Because you have run the script without arguments, the script displays no values for the arguments.

Now try running the script with a few arguments, like this:

```
./simple "This is one argument" second-argument third
```

This time the script displays more output:

```
This script's name is: ./simple
Argument 1: This is one argument
Argument 2: second-argument
```

As the output shows, the shell treats the entire string within the double quotation marks as a single argument. Otherwise the shell uses spaces as separators between arguments on the command line.

This sample script ignores the third argument because the script is designed to print only the first two arguments.

Exploring the Basics of Shell Scripting

Like any programming language, the `bash` shell supports the following features:

- ◆ Variables that store values, including special built-in variables for accessing command-line arguments passed to a shell script and other special values.
- ◆ The capability to evaluate expressions.
- ◆ Control structures that enable you to loop over several shell commands or to execute some commands conditionally.
- ◆ The capability to define functions that can be called in many places within a script. `bash` also includes many built-in commands that you can use in any script.

The next few sections illustrate some of these programming features through simple examples. (It's assumed that you're already running `bash`, in which case, you can try the examples by typing them at the shell prompt in a terminal window. Otherwise all you have to do is open a terminal window; `bash` runs and displays its prompt in that window.)

Storing stuff

You define variables in `bash` just as you define environment variables. Thus you may define a variable as follows:

```
count=12 # note no embedded spaces allowed
```

To use a variable's value, prefix the variable's name with a dollar sign (`$`). For example, `$PATH` is the value of the variable `PATH`. (This variable is the

famous `PATH` environment variable that lists all the directories that `bash` searches when trying to locate an executable file.) To display the value of the variable `count`, use the following command:

```
echo $count
```

`bash` has some special variables for accessing command-line arguments. In a shell script, `$0` refers to the name of the shell script. The variables `$1`, `$2`, and so on refer to the command-line arguments. The variable `$*` stores all the command-line arguments as a single variable, and `$?` contains the exit status of the last command the shell executes.

From a `bash` script, you can prompt the user for input and use the `read` command to read the input into a variable. Here is an example:

```
echo -n "Enter value: "  
read value  
echo "You entered: $value"
```

When this script runs, the `read value` command causes `bash` to read whatever you type at the keyboard and store your input in the variable called `value`.

Note: The `-n` option prevents the `echo` command from automatically adding a new line at the end of the string that it displays.

Calling shell functions

You can group a number of shell commands that you use consistently into a *function* and assign it a name. Later, you can execute that group of commands by using the single name assigned to the function. Here is a simple script that illustrates the syntax of shell functions:

```
#!/bin/sh  
hello() {  
  echo -n "Hello, "  
  echo $1 $2  
}  
hello Jane Doe
```

When you run this script, it displays the following output:

```
Hello, Jane Doe
```

This script defines a shell function named `hello`. The function expects two arguments. In the body of the function, these arguments are referenced by `$1` and `$2`. The function definition begins with `hello()` — the name of the function, followed by parentheses. The body of the function is enclosed in curly braces — `{ . . . }`. In this case, the body uses the `echo` command to display a line of text.

The last line of the example shows how a shell function is called with arguments. In this case, the `hello` function is called with two arguments: `Jane` and `Doe`. The `hello` function takes these two arguments and prints a line that says `Hello, Jane Doe`.

Controlling the flow

In `bash` scripts, you can control the flow of execution — the order in which the commands are executed — by using special commands such as `if`, `case`, `for`, and `while`. These control statements use the exit status of a command to decide what to do next. When any command executes, it returns an exit status — a numeric value that indicates whether or not the command has succeeded. By convention, an exit status of zero means the command has succeeded. (Yes, you read it right: Zero indicates success!) A nonzero exit status indicates that something has gone wrong with the command.

For example, suppose that you want to make a backup copy of a file before editing it with the `vi` editor. More importantly, you want to avoid editing the file if a backup can't be made. Here's a `bash` script that takes care of this task:

```
#!/bin/sh
if cp "$1" "#$1"
then
vi "$1"
else
echo "Failed to create backup copy"
fi
```

This script illustrates the syntax of the `if-then-else` structure and shows how the exit status of the `cp` command is used by the `if` command to determine the next action. If `cp` returns zero, the script uses `vi` to edit the file; otherwise, the script displays an error message and exits. By the way, the script saves the backup in a file whose name is the same as that of the original, except for a hash mark (`#`) added at the beginning of the filename.



Don't forget the final `fi` that terminates the `if` command. Forgetting `fi` is a common source of errors in `bash` scripts.

You can use the `test` command to evaluate any expression and to use the expression's value as the exit status of the command. Suppose that you want a script that edits a file only if it already exists. Using `test`, you can write such a script as follows:

```
#!/bin/sh
if test -f "$1"
then
vi "$1"
else
echo "No such file"
fi
```

A shorter form of the `test` command is to place the expression in square brackets (`[. . .]`). Using this shorthand notation, you can rewrite the preceding script like this:

```
#!/bin/sh
if [ -f "$1" ]
then
vi "$1"
else
echo "No such file"
fi
```

Note: You must have spaces around the two square brackets.

Another common control structure is the `for` loop. The following script adds the numbers 1 through 10:

```
#!/bin/sh
sum=0
for i in 1 2 3 4 5 6 7 8 9 10
do
sum='expr $sum + $i'
done
echo "Sum = $sum"
```

This example also illustrates the use of the `expr` command to evaluate an expression.

The `case` statement is used to execute a group of commands based on the value of a variable. For example, consider the following script:

```
#!/bin/sh
echo -n "What should I do -- (Y)es/(N)o/(C)ontinue? [Y] "
read answer
case $answer in
y|Y|"")
echo "YES"
;;
c|C)
echo "CONTINUE"
;;
n|N)
echo "NO"
;;
*)
echo "UNKNOWN"
;;
esac
```

Save this code in a file named `confirm` and type **`chmod +x confirm`** to make it executable. Then try it out like this:

```
./confirm
```

When the script prompts you, type one of the characters `y`, `n`, or `c` and press Enter. The script displays `YES`, `NO`, or `CONTINUE`, respectively. For example, here's what happens when you type `c` (and then press Enter):

```
What should I do -- (Y)es/(N)o/(C)ontinue? [Y] c
CONTINUE
```

The script displays a prompt and reads the input you type. Your input is stored in a variable named `answer`. Then the `case` statement executes a block of code based on the value of the `answer` variable. For example, when you type `c`, the following block of commands executes:

```
c|C)
echo "CONTINUE"
;;
```

The `echo` command causes the script to display `CONTINUE`.

From this example, you can see that the general syntax of the `case` command is as follows:

```
case $variable in
value1 | value2)
command1
command2
. . . other commands . . .
;;
value3)
command3
command4
. . . other commands . . .
;;
esac
```

Essentially, the `case` command begins with the word `case` and ends with `esac`. Separate blocks of code are enclosed between the values of the variable, followed by a closing parenthesis and terminated by a pair of semicolons (`;;`).

Exploring bash's built-in commands

`bash` has more than 50 built-in commands, including common commands such as `cd` and `pwd`, as well as many others that are used infrequently. You can use these built-in commands in any `bash` script or at the shell prompt. Table 1-1 describes most of the `bash` built-in commands and their arguments. After looking through this information, type **`help command`** to read more

about a specific built-in command. For example, to find out more about the built-in command `test`, type the following:

```
help test
```

Doing so displays the following information:

```
test: test [expr]
Exits with a status of 0 (true) or 1 (false) depending on
the evaluation of EXPR. Expressions may be unary or binary. Unary
expressions are often used to examine the status of a file. There
are string operators as well, and numeric comparison operators.
File operators:
-a FILE True if file exists.
-b FILE True if file is block special.
-c FILE True if file is character special.
-d FILE True if file is a directory.
-e FILE True if file exists.
-f FILE True if file exists and is a regular file.
-g FILE True if file is set-group-id.
-h FILE True if file is a symbolic link.
-L FILE True if file is a symbolic link.
-k FILE True if file has its 'sticky' bit set.
-p FILE True if file is a named pipe.
-r FILE True if file is readable by you.
-s FILE True if file exists and is not empty.
-S FILE True if file is a socket.
-t FD True if FD is opened on a terminal.
-u FILE True if the file is set-user-id.
-w FILE True if the file is writable by you.
-x FILE True if the file is executable by you.
-O FILE True if the file is effectively owned by you.
-G FILE True if the file is effectively owned by your group.
( . . . Lines deleted . . . )
```

Where necessary, the online help from the `help` command includes a considerable amount of detail.

Table 1-1 Summary of Built-in Commands in bash Shell

| <i>This Function</i> | <i>Does the Following</i> |
|--|---|
| <code>. filename [arguments]</code> | Reads and executes commands from the specified <i>filename</i> using the optional <i>arguments</i> . (Works the same way as the <code>source</code> command.) |
| <code>: [arguments]</code> | Expands the <i>arguments</i> but does not process them. |
| <code>[expr]</code> | Evaluates the expression <i>expr</i> and returns zero status if <i>expr</i> is true. |
| <code>alias</code> <code>[name[=value] . . .]</code> | Allows one <i>value</i> to equal another. For example, you could set <i>xyz</i> to run <i>bg</i> . |

| <i>This Function</i> | <i>Does the Following</i> |
|---|---|
| <code>bg [job]</code> | Puts the specified <i>job</i> in the background. If no <i>job</i> is specified, it puts the currently executing command in the background. |
| <code>break [n]</code> | Exits from a <code>for</code> , <code>while</code> , or <code>until</code> loop. If <i>n</i> is specified, the <i>n</i> th enclosing loop is exited. |
| <code>cd [dir]</code> | Changes the current directory to <i>dir</i> . |
| <code>command [-pVv] cmd [arg . . .]</code> | Runs the command <i>cmd</i> with the specified arguments (ignoring any shell function named <i>cmd</i>). |
| <code>continue [n]</code> | Starts the next iteration of the <code>for</code> , <code>while</code> , or <code>until</code> loop. If <i>n</i> is specified, the next iteration of the <i>n</i> th enclosing loop is started. |
| <code>declare [-frxi] [name[=value]]</code> | Declares a variable with the specified <i>name</i> and optionally, assigns it a <i>value</i> . |
| <code>dirs [-l] [+/-n]</code> | Displays the list of currently remembered directories. |
| <code>echo [-neE] [arg . . .]</code> | Displays the arguments, <i>arg . . .</i> , on standard output. |
| <code>enable [-n] [-all]</code> | Enables or disables the specified built-in commands. |
| <code>eval [arg . . .]</code> | Concatenates the arguments, <i>arg . . .</i> , and executes them as a command. |
| <code>exec [command [arguments]]</code> | Replaces the current instance of the shell with a new process that runs the specified <i>command</i> . with the given <i>arguments</i> . |
| <code>exit [n]</code> | Exits the shell with the status code <i>n</i> . |
| <code>export [-nf] [name[=word]] . . .</code> | Defines a specified environment variable and exports it to future processes. |
| <code>fc -s [pat=rep] [cmd]</code> | Re-executes the command after replacing the pattern <i>pat</i> with <i>rep</i> . |
| <code>fg [jobspec]</code> | Puts the specified job, <i>jobspec</i> , in the foreground. If no job is specified, it puts the most recent job in the foreground. |

(continued)

| This Function | Does the Following |
|--|---|
| hash [-r] [name] | Remembers the full pathname of a specified command. |
| help [cmd . . .] | Displays help information for specified built-in commands, <i>cmd</i> |
| history [n] | Displays past commands or past <i>n</i> commands, if you specify a number <i>n</i> . |
| jobs [-lnp] [jobspec . . .] | Lists currently active jobs. |
| kill [-s sigspec -sigspec] [pid jobspec] . . . let arg [arg . . .] | Evaluates each argument and returns 1 if the last <i>arg</i> is 0. |
| local [name[=value] . . .] | Creates a local variable with the specified <i>name</i> and <i>value</i> (used in shell functions). |
| logout | Exits a login shell. |
| popd [+/-n] | Removes the specified number of entries from the directory stack. |
| pushd [dir] | Adds a specified directory, <i>dir</i> , to the top of the directory stack. |
| pwd | Prints the full pathname of the current working directory. |
| read [-r] [name . . .] | Reads a line from standard input and parses it. |
| readonly [-f] [name . . .] | Marks the specified variables as read-only so that the variables cannot be changed later. |
| return [n] | Exits the shell function with the return value <i>n</i> . |
| set [--abefhkmnptuvxldCHP] [-o option] [arg . . .] | Sets various flags. |
| shift [n] | Makes the <i>n</i> +1 argument \$1, the <i>n</i> +2 argument \$2, and so on. |
| times | Prints the accumulated user and system times for processes run from the shell. |
| trap [-l] [cmd] [sigspec] | Executes <i>cmd</i> when the signal <i>sigspec</i> is received. |

| <i>This Function</i> | <i>Does the Following</i> |
|--|--|
| <code>type [-all] [-type -path] name [name . . .]</code> | Indicates how the shell interprets each <i>name</i> . |
| <code>ulimit [-SHacdfmstpnv [limit]]</code> | Controls resources available to the shell. |
| <code>umask [-S] [mode]</code> | Sets the <i>file creation mask</i> —the default permission to the <i>mode</i> specified for the files. |
| <code>unalias [-a] [name . . .]</code> | Undefines a specified alias. |
| <code>unset [-fv] [name . . .]</code> | Removes the definition of specified variables. |
| <code>wait [n]</code> | Waits for a specified process (<i>n</i> represents its PID) to terminate. |



Some external programs may have the same name as `bash` built-in commands. If you want to run any such external program, you have to specify explicitly the full pathname of that program. Otherwise `bash` executes the built-in command of the same name.

Chapter 2: Advanced Shell Scripting

In This Chapter

- ✓ Trying out the `sed` command
- ✓ Working with the `awk` and `sed` commands
- ✓ Reading some final notes on shell scripting

The preceding chapter introduces you to some of the power available through shell scripting. All the scripts in that chapter are simple `bash` routines that allow you to run commands and repeat operations a number of times.

This chapter builds upon that knowledge by showing how to incorporate two powerful tools — `sed` and `awk` — into your scripts. These two utilities move your scripts to the place where the only limit to what you can do becomes your ability to figure out how to ask for the output you need. Although `sed` is the stream editor and `awk` is a quick programming language, they complement each other so well that it's not uncommon to use one with the other. The best way to show how these tools work is to walk through some examples.

Trying Out sed

The following are sample lines of a colon-delimited employee database that has five fields: unique id number, name, department, phone number, and address.

```
1218:Kris Cottrell:Marketing:219.555.5555:123 Main Street
1219:Nate Eichhorn:Sales:219.555.5555:1219 Locust Avenue
1220:Joe Gunn:Payables:317.555.5555:21974 Unix Way
1221:Anne Heltzel:Finance:219.555.5555:652 Linux Road
1222:John Kuzmic:Human Resources:219.555.5555:984 Bash Lane
```

This database has been in existence since the beginning of the company and has grown to include everyone who now works, or has ever worked, for the company. A number of proprietary scripts read from the database, and the company cannot afford to be without it. The problem is that the telephone company has changed the 219 prefix to 260, so all entries in the database need to be changed.

This is precisely the task for which `sed` was created. As opposed to standard (interactive) editors, a *stream editor* works its way through a file and makes changes based on the rules it is given. The rule in this case is to change 219 to 260. It's not quite that simple, however, because if you use the command

```
sed 's/219/260/'
```

the result is not completely what you want (changes are in **bold**):

```
1218:Kris Cottrell:Marketing:260.555.5555:123 Main Street
1260:Nate Eichhorn:Sales:219.555.5555:1219 Locust Avenue
1220:Joe Gunn:Payables:317.555.5555:26074 Unix Way
1221:Anne Heltzel:Finance:260.555.5555:652 Linux Road
1222:John Kuzmic:Human Resources:260.555.5555:984 Bash Lane
```

The changes in the first, fourth, and fifth lines are correct. But in the second line, the first occurrence of 219 appears in the employee id number rather than in the phone number and was changed to 260. If you wanted to change more than the very first occurrence in a line, you could slap a `g` (for *global*) into the command:

```
sed 's/219/260/g'
```

That is *not* what you want to do in this case, however, because the employee id number should not change. Similarly, in the third line, a change was made to the address because it contains the value that is being searched for; no change should have been made because the employee does not have the 219 telephone prefix.

The first rule of using `sed` is to identify what makes the location of the string you are looking for unique. If the telephone prefix were encased in parentheses, it would be much easier to isolate. In this database, though, that is not the case; the task becomes a bit more complicated.

If you said that the telephone prefix must appear at the beginning of the field (denoted by a colon), the result would be much closer to what you want:

```
sed 's/:219/:260/'
```

Again, bolding has been added to show the changes:

```
1218:Kris Cottrell:Marketing:260.555.5555:123 Main Street
1219:Nate Eichhorn:Sales:260.555.5555:1219 Locust Avenue
1220:Joe Gunn:Payables:317.555.5555:26074 Unix Way
1221:Anne Heltzel:Finance:260.555.5555:652 Linux Road
1222:John Kuzmic:Human Resources:260.555.5555:984 Bash Lane
```

The accuracy has increased, but there is still the problem of the third line. Because the colon helped to identify the start of the string, it may be tempting to turn to the period to identify the end:

```
sed 's/:219./:260./'
```

But the result still isn't what was hoped for (note the third line):

```
1218:Kris Cottrell:Marketing:260.555.5555:123 Main Street
1219:Nate Eichhorn:Sales:260.555.5555:1219 Locust Avenue
1220:Joe Gunn:Payables:317.555.5555:260.4 Unix Way
1221:Anne Heltzel:Finance:260.555.5555:652 Linux Road
1222:John Kuzmic:Human Resources:260.555.5555:984 Bash Lane
```

Because the period has a special meaning of *any character*, a match is found whether the 219 is followed by a period, a 7, or any other single character. Whatever the character, it is replaced with a period. The replacement side of things isn't the problem; the search needs to be tweaked. By using the `\` character, we can override the special meaning of the period and specify that you are indeed looking for a period and not any single character:

```
sed 's/:219\./.:260./'
```

The result becomes:

```
1218:Kris Cottrell:Marketing:260.555.5555:123 Main Street
1219:Nate Eichhorn:Sales:260.555.5555:1219 Locust Avenue
1220:Joe Gunn:Payables:317.555.5555:21974 Unix Way
1221:Anne Heltzel:Finance:260.555.5555:652 Linux Road
1222:John Kuzmic:Human Resources:260.555.5555:984 Bash Lane
```

And the mission is accomplished.

Working with *awk* and *sed*

The second example involves a database of books that includes the ISBN number of each title. In the old days, ISBN numbers were ten digits and included an identifier for the publisher and a unique number for each book. ISBN numbers are now thirteen digits for new books. Old books (those published before the first of 2007) have both the old 10-digit and a new 13-digit number that can be used to identify them. For this example, the existing 10-digit number will stay in the database and a new field — holding the ISBN-13 number — will be added to the end of each entry.

To come up with the ISBN-13 number for the existing entries in the database, you start with 978, then use the first 9 digits of the old ISBN number. The thirteenth digit is a mathematical calculation (a *check digit*) obtained by doing the following:

1. Add all odd-placed digits (the first, the third, the fifth, and so on).
2. Multiply all even-placed digits by 3 and add them.
3. Add the total of Step #2 to the total of Step #1.
4. Find out what you need to add to round the number up to the nearest 10. This value becomes the thirteenth digit.

For example, consider the 10-digit ISBN 0743477103. It first becomes 978074347710, and then the steps work out like this:

1. $9+8+7+3+7+1=35$
2. $7*3=21$; $0*3=0$; $4*3=12$; $4*3=12$; $7*3=21$; $0*3=0$; $21+0+12+12+21+0=66$
3. $66+35=101$
4. $110-101=9$. The ISBN-13 thus becomes 9780743477109.

The beginning database resembles:

```
0743477103:Macbeth:Shakespeare, William
1578518520:The Innovator's Solution:Christensen, Clayton M.
0321349946:(SCTS) Symantec Certified Technical Specialist:Alston, Nik
1587052415:Cisco Network Admission Control, Volume I:Helfrich, Denise
```

And you want the resulting database to change so each line resembles something like this:

```
0743477103:Macbeth:Shakespeare, William:9780743477109
```

The example that follows accomplishes this goal. It's not the prettiest thing ever written, but it walks through the process of tackling this problem, illustrating the use of `awk` and `sed`. I have also included writing to temporary files so you can examine those files and see the contents at various stages. Clean programming would mitigate the use of temporary files everywhere possible, but that practice also makes it difficult to follow the action at times. That said, here is one solution out of dozens. Read on.

Step 1: Pull out the ISBN

Given the database as it now exists, the first order of business is to pull out the existing ISBN — only the first nine digits because the tenth digit, which was just a checksum, no longer matters — and slap 978 onto the beginning. The nine digits we want are the first nine characters of each line, so we can pull them out by using the `cut` utility:

```
cut -c1e-9 books
```

Because a mathematical operation will be performed on the numbers comprising this value, and that operation works with each digit, I'll add a space between each number and the next in the new entry:

```
sed 's/[0-9]/& /g'
```

Now it's time to add the new code to the beginning of each entry (the start of every line):

```
sed 's/^/9 7 8 /'
```

And finally, I do an extra step: removing the white space at the end of the line just to make the entry a bit cleaner:

```
sed 's/ $//'
```

Then I write the results to a temporary file that can be examined to make sure all is working as it should. The full first step then becomes

```
cut -c1-9 books | sed 's/[0-9]/& /g' | sed 's/^/9 7 8 /' | sed 's/ $//> isbn2
```

Note: the *sed* operations could be combined in a script file to increase speed and decrease cycles. However, I am walking through each operation step-by-step to show what's going on, and am not worried about creating script files for this one-time-only operation.

Examining the temporary file, the contents are as follows:

```
9 7 8 0 7 4 3 4 7 7 1 0
9 7 8 1 5 7 8 5 1 8 5 2
9 7 8 0 3 2 1 3 4 9 9 4
9 7 8 1 5 8 7 0 5 2 4 1
```

Step 2: Calculate the 13th digit

We've taken care of the first 12 digits of the ISBN number. Now we need to compute those 12 digits to figure out the thirteenth value. Because the numbers are separated by a space, *awk* can interpret them as fields. The calculation will take several steps:

1. Add all the odd-placed digits: $x = \$1 + \$3 + \$5 + \$7 + \$9 + \11 .
2. Add all the even-placed digits and multiply by 3:
 $y = (\$2 + \$4 + \$6 + \$8 + \$10 + \$12) * 3$.
3. Add the total of Step #2 to the total of Step #1: $x = x + y$.
4. Find out what you need to add to round the number up to the nearest 10 by computing the modulo when divided by 10, and then subtracting it from 10. The following *awk* command gets everything in place except the transformation:

```
awk '{ x=$1+$3+$5+$7+$9+$11 ; y=$2+$4+$6+$8+$10+$12 ; y=y*3 ; x=x+y ;
      y=x%10 ; print y }'
```

Everything is finished except subtracting the final result from 10. This is the hardest part. If the modulo is 7, for example, the check digit is 3. If the modulo is 0, however, the check digit does not become 10 ($10 - 0$), but stays 0. My solution is to use the transform function of *sed*:

```
sed 'y/12346789/98764321/'
```

Combining the two operations into one, the second step thus becomes

```
awk '{ x=$1+$3+$5+$7+$9+$11 ; y=$2+$4+$6+$8+$10+$12 ; y=y*3 ; x=x+y ; y=x%10 ;
      print y }' | sed 'y/12346789/98764321/' > isbn3
```

Examining the temporary file, the contents are

```
9
4
1
5
```

Step 3: Add the 13th digit to the other 12

The two temporary files can now be combined to get the correct 13-digit ISBN number. Just as `cut` was used in the earlier step, `paste` can be used now to combine the files. The default delimiter for `paste` is a tab, but we can change that to anything with the `-d` option. I use a space as the delimiter, and then use `sed` to strip the spaces (remember that the `isbn2` file has spaces between the digits so that they can be read as fields):

```
paste -d" " isbn2 isbn3 | sed 's/ //g'
```

Finally, I want to add a colon as the first character of each entry to make it easier to append the newly computed ISBN to the existing file:

```
sed 's/^:/'
```

And the entire command becomes

```
paste -d" " isbn2 isbn3 | sed 's/ //g' | sed 's/^:/' > isbn4
```

Examining the temporary file, the contents are

```
:9780743477109
:9781578518524
:9780321349941
:9781587052415
```

Step 4: Finish the process

The only operation remaining is to append the values in the temporary file to the current database. I'll use the default tab delimiter in the entry, and then strip it out. Technically, I could specify a colon as the delimiter and avoid the last part of the last steps. However, I would rather have my value complete there and be confident that I am stripping characters that don't belong (tabs) instead of running the risk of adding more characters than should be there. The final command is

```
paste books isbn4 | sed 's/\t//g' > newbooks
```

The final file looks like this:

```
0743477103:Macbeth:Shakespeare, William:9780743477109
1578518520:The Innovator's Solution:Christensen, Clayton M.:9781578518524
0321349946:(SCTS) Symantec Certified Technical Specialist:Alston,
    Nik:9780321349941
1587052415:Cisco Network Admission Control, Volume I:Helfrich,
    Denise:9781587052415
```

Again, this result can be accomplished in many ways. This solution is not the cleanest, but it does illustrate the down-and-dirty use of `sed` and `awk`.

Final Notes on Shell Scripting

As with any other aspect of computing, it takes a while to get used to shell scripting. After you become comfortable writing scripts, however, you'll find that you can automate any number of operations and simplify your task as an administrator. The following tips can be helpful to keep in mind:

- ◆ After you create a script, you can run it automatically on a one-time basis by using `at`, or on a regular basis by using `cron`.
- ◆ You can use *conditional expressions*, such as `if`, `while`, and `until`, to look for events to occur (such as certain users accessing a file they should not) or to let you know when something that should be there goes away (for example, a file is removed or a user terminates).
- ◆ You can set permissions on shell scripts in the same way you set permissions for other files. For example, you can create scripts that are shared by all members of your administrative group (use `case` to create menus based upon `LOGNAME`).

Chapter 3: Programming in Linux

In This Chapter

- ✓ Figuring out programming
- ✓ Exploring the software-development tools in Linux
- ✓ Compiling and linking programs with GCC
- ✓ Using `make`
- ✓ Debugging programs with `gdb`
- ✓ Understanding the implications of GNU, GPL, and LGPL

Linux comes loaded with all the tools you need to develop software. (All you have to do is install them.) In particular, it has all the GNU software-development tools, such as GCC (C and C++ compiler), GNU `make`, and the GNU debugger. Whereas the previous two chapters look at some simple tools and shell scripts, this chapter introduces you to programming, describes the software-development tools, and shows you how to use them. Although I provide examples in the C and C++ programming languages, the focus is not on showing you how to program in those languages but on showing you how to use various software-development tools (such as compilers, `make`, and debugger).

The chapter concludes with a brief explanation of how the Free Software Foundation's GNU General Public License (GPL) may affect any plans you might have to develop Linux software. You need to know about the GPL because you use GNU tools and GNU libraries to develop software in Linux.

An Overview of Programming

If you've written computer programs in any programming language, even the shell scripts from the previous two chapters, you can start writing programs on your Linux system quickly. If you've never written a computer program, however, you need two basic resources before you begin to write code: a look at the basics of programming and a quick review of computers and their major parts. This section offers an overview of computer programming — just enough to get you going.

At its simplest, a *computer program* is a sequence of instructions for performing a specific task, such as adding two numbers or searching for some text in a file. Consequently, computer programming involves *creating* that list of

instructions, telling the computer how to complete a specific task. The exact instructions depend on the programming language that you use. For most programming languages, you have to go through the following steps to create a computer program:

1. Use a text editor to type the sequence of commands from the programming language.

This sequence of commands accomplishes your task. This human-readable version of the program is called the *source file* or *source code*. You can create the source file with any application (such as a word processor) that can save a document in plain-text form.



Always save your source code as plain text. (The filename depends on the type of programming language.) Word processors can sometimes put extra instructions in their documents that tell the computer to display the text in a particular font or other format. Saving the file as plain text deletes any and all such extra instructions. Trust me, your program is much better off without such stuff.

2. Use a *compiler* program to convert that text file — the source code — from human-readable form into machine-readable *object code*.

Typically, this step also combines several object code files into a single machine-readable computer program, something that the computer can run.

3. Use a special program called a *debugger* to track down any errors and find which lines in the source file might have caused the errors.

4. Go back to Step 1 and use the text editor to correct the errors, and repeat the rest of the steps.

These steps are referred to as the *edit-compile-debug cycle* of programming because most programmers have to repeat this sequence several times before a program works correctly.

In addition to knowing the basic programming steps, you also need to be familiar with the following terms and concepts:

- ◆ *Variables* are used to store different types of data. You can think of each variable as being a placeholder for data — kind of like a mailbox, with a name and room to store data. The content of the variable is its *value*.
- ◆ *Expressions* combine variables by using operators. One expression may add several variables; another may extract a part of a *string* (series of sequential characters).
- ◆ *Statements* perform some action, such as assigning a value to a variable or printing a string.
- ◆ *Flow-control statements* allow statements to execute in various orders, depending on the value of some expression. Typically, flow-control statements include *for*, *do-while*, *while*, and *if-then-else* statements.

- ◆ *Functions* (also called *subroutines* or *routines*) allow you to group several statements and give the group a name. You can use functions to execute the same set of statements over and over by invoking the function that represents those statements. Typically, a programming language provides many predefined functions to perform tasks, such as opening (and reading from) a file.

Exploring the Software-Development Tools in Linux

Linux includes the following traditional Unix software-development tools:

- ◆ **Text editors** such as `vi` and `emacs` for editing the source code. (To find out more about `vi`, see Book II, Chapter 6.)
- ◆ A **C compiler** for compiling and linking programs written in C — the programming language of choice for writing Unix applications (though nowadays, many programmers are turning to C++ and Java). Linux includes the GNU C and C++ compilers. Originally the GNU C compiler was known as GCC — which now stands for *GNU Compiler Collection*. (See a description at <http://gcc.gnu.org>.)
- ◆ The **GNU make utility** for automating the software *build process* — the process of combining object modules into an executable or a library. (The operating system can load and run an *executable*; a *library* is a collection of binary code that can be used by executables.)
- ◆ A **debugger** for debugging programs. Linux includes the GNU debugger `gdb`.
- ◆ A **version control system** to keep track of various revisions of a source file. Linux comes with RCS (Revision Control System) and CVS (Concurrent Versions System). Nowadays, most open source projects use CVS as their version control system, but a recent version control system called Subversion is being developed as a replacement for CVS.



You can install these software-development tools in any Linux distribution:

- ◆ **Xandros:** Usually the tools are installed by default.
- ◆ **Fedora:** Select the Development Tools package during installation.
- ◆ **Debian:** Type `apt-get install gcc` and then `apt-get install libc6-dev` in a terminal window.
- ◆ **SUSE:** Choose Main Menu → System → YaST, click Software on the left side of the window, and then click Install and Remove Software. Type `gcc` in the search field in YaST, select the relevant packages from the search results, and click Accept to install. If you find any missing packages, you can install them in a similar manner.

The next few sections briefly describe how to use these software-development tools to write applications for Linux.

GNU C and C++ compilers

The most important software-development tool in Linux is GCC — the GNU C and C++ compiler. In fact, GCC can compile three languages: C, C++, and Objective-C (a language that adds object-oriented programming capabilities to C). You use the same `gcc` command to compile and link both C and C++ source files. The GCC compiler supports ANSI-standard C, making it easy to port any ANSI C program to Linux. In addition, if you've ever used a C compiler on other Unix systems, you should feel right at home with GCC.

Using GCC

Use the `gcc` command to invoke GCC. By default, when you use the `gcc` command on a source file, GCC preprocesses, compiles, and links to create an executable file. However, you can use GCC options to stop this process at an intermediate stage. For example, you might invoke `gcc` by using the `-c` option to compile a source file and to generate an object file, but not to perform the link step.

Using GCC to compile and link a few C source files is easy. Suppose you want to compile and link a simple program made up of two source files. To accomplish this task, use the following program source code; the task that is stored in the file `area.c` computes the area of a circle whose radius is specified at the command line:

```
#include <stdio.h>
#include <stdlib.h>
/* Function prototype */
double area_of_circle(double r);
int main(int argc, char **argv)
{
    if(argc < 2)
    {
        printf("Usage: %s radius\n", argv[0]);
        exit(1);
    }
    else
    {
        double radius = atof(argv[1]);
        double area = area_of_circle(radius);
        printf("Area of circle with radius %f = %f\n",
            radius, area);
    }
    return 0;
}
```

You need another file that actually computes the area of a circle. Here's the listing for the `circle.c` file, which defines a function that computes the area of a circle:

```
#include <math.h>
#define SQUARE(x) ((x)*(x))
double area_of_circle(double r)
```

```
{
return 4.0 * M_PI * SQUARE(r);
}
```

For such a simple program, of course, we could place everything in a single file, but this example was contrived a bit to show you how to handle multiple files.

To compile these two files and to create an executable file named `area`, use this command:

```
gcc -o area area.c circle.c
```

This invocation of GCC uses the `-o` option to specify the name of the executable file. (If you don't specify the name of an output file with the `-o` option, GCC saves the executable code in a file named `a.out`.)

If you have too many source files to compile and link, you can compile the files individually and generate *object files* (that have the `.o` extension). That way, when you change a source file, you need to compile only that file — you just link the compiled file to all the object files. The following commands show how to separate the compile and link steps for the sample program:

```
gcc -c area.c
gcc -c circle.c
gcc -o area area.o circle.o
```

The first two commands run `gcc` with the `-c` option compiling the source files. The third `gcc` command links the object files into an executable named `area`.

Compiling C++ programs

GNU CC is a combined C and C++ compiler, so the `gcc` command also can compile C++ source files. GCC uses the file extension to determine whether a file is C or C++. C files have a lowercase `.c` extension, whereas C++ files end with `.C` or `.cpp`.



Although the `gcc` command can compile a C++ file, that command doesn't automatically link with various class libraries that C++ programs typically require. Compiling and linking a C++ program by using the `g++` command is easy because it runs `gcc` with appropriate options.

Suppose you want to compile the following simple C++ program stored in a file named `hello.C`. (Using an uppercase C extension for C++ source files is customary.)

```
#include <iostream>
int main()
{
using namespace std;
cout << "Hello from Linux!" << endl;
}
```

To compile and link this program into an executable program named `hello`, use this command:

```
g++ -o hello hello.C
```

The command creates the `hello` executable, which you can run as follows:

```
./hello
```

The program displays the following output:

```
Hello from Linux!
```

A host of GCC options controls various aspects of compiling C and C++ programs.

Exploring GCC options

Here's the basic syntax of the `gcc` command:

```
gcc options filenames
```

Each option starts with a hyphen (-) and usually has a long name, such as `-funsigned-char` or `-finline-functions`. Many commonly used options are short, however, such as `-c`, to compile only, and `-g`, to generate debugging information (needed to debug the program by using the GNU debugger, `gdb`).

You can view a summary of all GCC options by typing the following command in a terminal window:

```
man gcc
```

Then you can browse through the commonly used GCC options. Usually, you don't have to provide GCC options explicitly because the default settings are fine for most applications. Table 3-1 lists some of the GCC options you may use.

| Table 3-1 | Common GCC Options |
|----------------------|---|
| <i>Option</i> | <i>Meaning</i> |
| <code>-ansi</code> | Supports only ANSI-standard C syntax. (This option disables some GNU C-specific features, such as the <code>__asm__</code> and <code>__typeof__</code> keywords.) When used with <code>g++</code> , supports only ISO-standard C++. |
| <code>-c</code> | Compiles and generates only the object file. |
| <code>-DMACRO</code> | Defines the macro with the string "1" as its value. |

| <i>Option</i> | <i>Meaning</i> |
|--------------------------|---|
| -DMACRO=DEFN | Defines the macro as DEFN, where DEFN is some text string. |
| -E | Runs only the C preprocessor. |
| -fallow-single-precision | Performs all math operations in single precision. |
| -fpcc-struct-return | Returns all struct and union values in memory, rather than in registers. (Returning values this way is less efficient, but at least it's compatible with other compilers.) |
| -fPIC | Generates position-independent code (PIC) suitable for use in a shared library. |
| -freg-struct-return | When possible, returns struct and union values registers. |
| -g | Generates debugging information. (The GNU debugger can use this information.) |
| -I DIRECTORY | Searches the specified directory for files that you include by using the #include preprocessor directive. |
| -L DIRECTORY | Searches the specified directory for libraries. |
| -l LIBRARY | Searches the specified library when linking. |
| -mcpu=cputype | Optimizes code for a specific processor. (cputype can take many different values — some common ones are i386, i486, i586, i686, pentium, pentiumpro, pentium2, pentium3, pentium4.) |
| -o FILE | Generates the specified output file (used to designate the name of an executable file). |
| -O0 (two zeros) | Does not optimize. |
| -O or -O1 (letter O) | Optimizes the generated code. |
| -O2 (letter O) | Optimizes even more. |
| -O3 (letter O) | Performs optimizations beyond those done for -O2. |
| -Os (letter O) | Optimizes for size (to reduce the total amount of code). |
| -pedantic | Generates errors if any non-ANSI-standard extensions are used. |
| -pg | Adds extra code to the program so that, when run, this program generates information that the gprof program can use to display timing details for various parts of the program. |

(continued)

Table 3-1 (continued)

| <i>Option</i> | <i>Meaning</i> |
|--------------------|--|
| -shared | Generates a shared object file (typically used to create a shared library). |
| -UMACRO | Undefines the specified macros. |
| -v | Displays the GCC version number. |
| -w | Doesn't generate warning messages. |
| -Wl, <i>OPTION</i> | Passes the <i>OPTION</i> string (containing multiple comma-separated options) to the linker. To create a shared library named <code>libXXX.so.1</code> , for example, use the following flag: <code>-Wl, -soname, libXXX.so.1</code> . |

The GNU make utility

When an application is made up of more than a few source files, compiling and linking the files by manually typing the `gcc` command can get tiresome. Also, you don't want to compile every file whenever you change something in a single source file. These situations are where the GNU `make` utility comes to your rescue.

The `make` utility works by reading and interpreting a *makefile* — a text file that describes which files are required to build a particular program as well as how to compile and link the files to build the program. Whenever you change one or more files, `make` determines which files to recompile — and it issues the appropriate commands for compiling those files and rebuilding the program.

Makefile names

By default, GNU `make` looks for a *makefile* that has one of the following names, in the order shown:

- ◆ `GNUmakefile`
- ◆ `makefile`
- ◆ `Makefile`

In Unix systems, using `Makefile` as the name of the *makefile* is customary because it appears near the beginning of directory listings, where uppercase names appear before lowercase names.

When you download software from the Internet, you usually find a `Makefile`, together with the source files. To build the software, you only have to type **make** at the shell prompt and `make` takes care of all the steps necessary to build the software.

If your makefile doesn't have a standard name (such as `Makefile`), you have to use the `-f` option with `make` to specify the makefile name. If your makefile is called `myprogram.mak`, for example, you have to run `make` using the following command line:

```
make -f myprogram.mak
```

The makefile

For a program made up of several source and header files, the makefile specifies the following:

- ◆ The items that `make` creates — usually the object files and the executable. Using the term *target* to refer to any item that `make` has to create is common.
- ◆ The files or other actions required to create the target.
- ◆ Which commands to execute to create each target.

Suppose that you have a C++ source file named `form.C` that contains the following preprocessor directive:

```
#include "form.h" // Include header file
```

The object file `form.o` clearly depends on the source file `form.C` and the header file `form.h`. In addition to these dependencies, you must specify how `make` converts the `form.C` file to the object file `form.o`. Suppose that you want `make` to invoke `g++` (because the source file is in C++) with these options:

- ◆ `-c` (compile only)
- ◆ `-g` (generate debugging information)
- ◆ `-O2` (optimize some)

In the makefile, you can express these options with the following rule:

```
# This a comment in the makefile
# The following lines indicate how form.o depends
# on form.C and form.h and how to create form.o.
form.o: form.C form.h
g++ -c -g -O2 form.C
```

In this example, the first noncomment line shows `form.o` as the target and `form.C` and `form.h` as the dependent files.

The line following the dependency indicates how to build the target from its dependents. This line must start with a tab. Otherwise the `make` command exits with an error message, and you're left scratching your head because when you look at the makefile in a text editor, you can't tell the difference between a tab and a space. Now that you know the secret, the fix is to replace the space at the beginning of the offending line with a single tab.



The benefit of using `make` is that it prevents unnecessary compilations. After all, you can run `g++` (or `gcc`) from a shell script to compile and link all the files that make up your application, but the shell script compiles everything, even if the compilations are unnecessary. GNU `make`, on the other hand, builds a target only if one or more of its dependents have changed since the last time the target was built. `make` verifies this change by examining the time of the last modification of the target and the dependents.

`make` treats the target as the name of a goal to be achieved; the target doesn't have to be a file. You can have a rule such as this one:

```
clean:
rm -f *.o
```

This rule specifies an abstract target named `clean` that doesn't depend on anything. This dependency statement says that to create the target `clean`, GNU `make` invokes the command `rm -f *.o`, which deletes all files that have the `.o` extension (namely, the object files). Thus, the effect of creating the target named `clean` is to delete the object files.

Variables (or macros)

In addition to the basic capability of building targets from dependents, GNU `make` includes many features that make it easy for you to express the dependencies and rules for building a target from its dependents. If you need to compile a large number of C++ files by using GCC with the same options, for example, typing the options for each file is tedious. You can avoid this repetitive task by defining a variable or macro in `make` as follows:

```
# Define macros for name of compiler
CXX= g++
# Define a macro for the GCC flags
CXXFLAGS= -O2 -g -mcpu=i686
# A rule for building an object file
form.o: form.C form.h
$(CXX) -c $(CXXFLAGS) form.C
```

In this example, `CXX` and `CXXFLAGS` are `make` variables. (GNU `make` prefers to call them *variables*, but most Unix `make` utilities call them *macros*.)

To use a variable anywhere in the `makefile`, start with a dollar sign (\$) followed by the variable within parentheses. GNU `make` replaces all occurrences of a variable with its definition; thus, it replaces all occurrences of `$(CXXFLAGS)` with the string `-O2 -g -mcpu=i686`.

GNU `make` has several predefined variables that have special meanings. Table 3-2 lists these variables. In addition to the variables listed in Table 3-2, GNU `make` considers all environment variables (such as `PATH` and `HOME`) to be predefined variables as well.

Table 3-2 Some Predefined Variables in GNU make

| <i>Variable</i> | <i>Meaning</i> |
|-----------------|--|
| \$% | Member name for targets that are archives. If the target is <code>libDisp.a(image.o)</code> , for example, <code>\$\$</code> is <code>image.o</code> . |
| \$* | Name of the target file without the extension. |
| \$+ | Names of all dependent files with duplicate dependencies, listed in their order of occurrence. |
| \$< | The name of the first dependent file. |
| \$? | Names of all dependent files (with spaces between the names) that are newer than the target. |
| \$@ | Complete name of the target. If the target is <code>libDisp.a image.o</code> , for example, <code>\$\$</code> is <code>libDisp.a</code> . |
| \$^ | Names of all dependent files, with spaces between the names. Duplicates are removed from the dependent filenames. |
| AR | Name of the archive-maintaining program (default value: <code>ar</code>). |
| ARFLAGS | Flags for the archive-maintaining program (default value: <code>rv</code>). |
| AS | Name of the assembler program that converts the assembly language to object code (default value: <code>as</code>). |
| ASFLAGS | Flags for the assembler. |
| CC | Name of the C compiler (default value: <code>cc</code>). |
| CFLAGS | Flags that are passed to the C compiler. |
| CO | Name of the program that extracts a file from RCS (default value: <code>co</code>). |
| COFLAGS | Flags for the RCS <code>co</code> program. |
| CPP | Name of the C preprocessor (default value: <code>\$(CC) -E</code>). |
| CPPFLAGS | Flags for the C preprocessor. |
| CXX | Name of the C++ compiler (default value: <code>g++</code>). |
| CXXFLAGS | Flags that are passed to the C++ compiler. |
| FC | Name of the FORTRAN compiler (default value: <code>f77</code>). |
| FFLAGS | Flags for the FORTRAN compiler. |
| LDFLAGS | Flags for the compiler when it's supposed to invoke the linker <code>ld</code> . |
| RM | Name of the command to delete a file (Default value: <code>rm -f</code>). |

A sample makefile

You can write a `makefile` easily if you use the predefined variables of GNU make and its built-in rules. Consider, for example, a `makefile` that creates the executable `xdraw` from three C source files (`xdraw.c`, `xviewobj.c`, and `shapes.c`) and two header files (`xdraw.h` and `shapes.h`). Assume that

each source file includes one of the header files. Given these facts, here is what a sample makefile may look like:

```
#####
# Sample makefile
# Comments start with '#'
#
#####
# Use standard variables to define compile and link flags
CFLAGS= -g -O2
# Define the target "all"
all: xdraw
OBSJ=xdraw.o xviewobj.o shapes.o
xdraw: $(OBSJ)
# Object files
xdraw.o: Makefile xdraw.c xdraw.h
xviewobj.o: Makefile xviewobj.c xdraw.h
shapes.o: Makefile shapes.c shapes.h
```

This makefile relies on GNU make's implicit rules. The conversion of `.c` files to `.o` files uses the built-in rule. Defining the variable `CFLAGS` passes the flags to the C compiler.



The target named `all` is defined as the first target for a reason — if you run GNU make without specifying any targets in the command line (see the `make` syntax described in the following section), the command builds the first target it finds in the makefile. By defining the first target `all` as `xdraw`, you can ensure that `make` builds this executable file, even if you don't explicitly specify it as a target. Unix programmers traditionally use `all` as the name of the first target, but the target's name is immaterial; what matters is that it's the first target in the makefile.

How to run make

Typically you run `make` by simply typing the following command at the shell prompt:

```
make
```

When run this way, GNU make looks for a file named `GNUmakefile`, `makefile`, or `Makefile` — in that order. If `make` finds one of these makefiles, it builds the first target specified in that makefile. However, if `make` doesn't find an appropriate makefile, it displays the following error message and exits:

```
make: *** No targets specified and no makefile found. Stop.
```

If your makefile happens to have a different name from the default names, you have to use the `-f` option to specify the makefile. The syntax of the `make` command with this option is

```
make -f filename
```

where `filename` is the name of the makefile.

Even when you have a `makefile` with a default name such as `Makefile`, you may want to build a specific target out of several targets defined in the `makefile`. In that case, you have to use the following syntax when you run `make`:

```
make target
```

For example, if the `makefile` contains the target named `clean`, you can build that target with this command:

```
make clean
```

Another special syntax overrides the value of a `make` variable. For example, GNU `make` uses the `CFLAGS` variable to hold the flags used when compiling C files. You can override the value of this variable when you invoke `make`. Here's an example of how you can define `CFLAGS` as the option `-g -O2`:

```
make CFLAGS="-g -O2"
```

In addition to these options, GNU `make` accepts several other command-line options. Table 3-3 lists the GNU `make` options.

| <i>Option</i> | <i>Meaning</i> |
|----------------------|---|
| <code>-b</code> | Ignores the variable given but accepts that variable for compatibility with other versions of <code>make</code> . |
| <code>-C DIR</code> | Changes to the specified directory before reading the <code>makefile</code> . |
| <code>-d</code> | Prints debugging information. |
| <code>-e</code> | Allows environment variables to override definitions of similarly named variables in the <code>makefile</code> . |
| <code>-f FILE</code> | Reads <code>FILE</code> as the <code>makefile</code> . |
| <code>-h</code> | Displays the list of <code>make</code> options. |
| <code>-i</code> | Ignores all errors in commands executed when building a target. |
| <code>-I DIR</code> | Searches the specified directory for included <code>makefiles</code> . (The capability to include a file in a <code>makefile</code> is unique to GNU <code>make</code> .) |
| <code>-j NUM</code> | Specifies the number of commands that <code>make</code> can run simultaneously. |
| <code>-k</code> | Continues to build unrelated targets, even if an error occurs when building one of the targets. |
| <code>-l LOAD</code> | Doesn't start a new job if load average is at least <code>LOAD</code> (a floating-point number). |

(continued)

Table 3-3 (continued)

| <i>Option</i> | <i>Meaning</i> |
|----------------|---|
| -m | Ignores the variable given but accepts that variable for compatibility with other versions of <code>make</code> . |
| -n | Prints the commands to execute but does not execute them. |
| -o <i>FILE</i> | Does not rebuild the file named <i>FILE</i> , even if it is older than its dependents. |
| -p | Displays the <code>make</code> database of variables and implicit rules. |
| -q | Does not run anything, but returns 0 (zero) if all targets are up to date, 1 if anything needs updating, or 2 if an error occurs. |
| -r | Gets rid of all built-in rules. |
| -R | Gets rid of all built-in variables and rules. |
| -s | Works silently (without displaying the commands as they execute). |
| -t | Changes the timestamp of the files. |
| -v | Displays the version number of <code>make</code> and a copyright notice. |
| -w | Displays the name of the working directory before and after processing the <code>makefile</code> . |
| -W <i>FILE</i> | Assumes that the specified file has been modified (used with <code>-n</code> to see what happens if you modify that file). |

The GNU debugger

Although `make` automates the process of building a program, that part of programming is the least of your worries when a program doesn't work correctly or when a program suddenly quits with an error message. You need a debugger to find the cause of program errors. Linux includes `gdb` — the versatile GNU debugger with a command-line interface.

Like any debugger, `gdb` lets you perform typical debugging tasks, such as the following:

- ◆ Set a breakpoint so that the program stops at a specified line.
- ◆ Watch the values of variables in the program.
- ◆ Step through the program one line at a time.
- ◆ Change variables in an attempt to correct errors.

The `gdb` debugger can debug C and C++ programs.

Preparing to debug a program

If you want to debug a program by using `gdb`, you have to ensure that the compiler generates and places debugging information in the executable. The debugging information contains the names of variables in your program and the mapping of addresses in the executable file to lines of code in the source file. `gdb` needs this information to perform its functions, such as stopping after executing a specified line of source code.



To make sure that the executable is properly prepared for debugging, use the `-g` option with GCC. You can do this task by defining the variable `CFLAGS` in the makefile as

```
CFLAGS= -g
```

Running gdb

The most common way to debug a program is to run `gdb` by using the following command:

```
gdb progname
```

`progname` is the name of the program's executable file. After `progname` runs, `gdb` displays the following message and prompts you for a command:

```
GNU gdb (GDB) 7.5.91.20130417-cvs-ubuntu
Copyright (c) 2013 Free Software Foundation, Inc.
License GPLv3+: GNU GPL version 3 or later
<http://gnu.org/licenses/gpl.html>
This is free software: you are free to change it and redistribute it.
There is NO WARRANTY, to the extent permitted by law. Type "show copying"
and "show warranty" for details.
This GDB was configured as "i686--linux-gnu".
For bug reporting instructions, please see:
http://www.gnu.org/software/gdb/bugs/.
(gdb)
```

You can type `gdb` commands at the `(gdb)` prompt. One useful command, `help`, displays a list of commands, as the next listing shows:

```
(gdb) help
List of classes of commands:
aliases -- Aliases of other commands
breakpoints -- Making program stop at certain points
data -- Examining data
files -- Specifying and examining files
internals -- Maintenance commands
obscure -- Obscure features
running -- Running the program
stack -- Examining the stack
status -- Status inquiries
support -- Support facilities
tracepoints -- Tracing of program execution without stopping the program
user-defined -- User-defined commands
```

Type "help" followed by a class name for a list of commands in that class.
 Type "help all" for the list of all commands.
 Type "help" followed by command name for full documentation.
 Command name abbreviations are allowed if unambiguous.
 (gdb)

To quit gdb, type q and then press Enter.

gdb has a large number of commands, but you need only a few to find the cause of an error quickly. Table 3-4 lists the commonly used gdb commands.

| Table 3-4 | Common gdb Commands |
|----------------------------|--|
| <i>This Command</i> | <i>Does the Following</i> |
| break <i>NUM</i> | Sets a breakpoint at the specified line number, <i>NUM</i> . (The debugger stops at breakpoints.) |
| bt | Displays a trace of all stack frames. (This command shows you the sequence of function calls so far.) |
| clear <i>FILENAME: NUM</i> | Deletes the breakpoint at a specific line number, <i>NUM</i> , in the source file <i>FILENAME</i> . For example, <code>clear xdraw.c:8</code> clears the breakpoint at line 8 of file <code>xdraw.c</code> . |
| continue | Continues running the program being debugged. (Use this command after the program stops due to a signal or breakpoint.) |
| display <i>EXPR</i> | Displays the value of an expression, <i>EXPR</i> (consisting of variables defined in the program) each time the program stops. |
| file <i>FILE</i> | Loads the specified executable file, <i>FILE</i> , for debugging. |
| help <i>NAME</i> | Displays help on the command named <i>NAME</i> . |
| info break | Displays a list of current breakpoints, including information on how many times each breakpoint is reached. |
| info files | Displays detailed information about the file being debugged. |
| info func | Displays all function names. |
| info local | Displays information about local variables of the current function. |
| info prog | Displays the execution status of the program being debugged. |
| info var | Displays all global and static variable names. |

| <i>This Command</i> | <i>Does the Following</i> |
|----------------------------------|---|
| kill | Ends the program you're debugging. |
| list | Lists a section of the source code. |
| make | Runs the make utility to rebuild the executable without leaving gdb. |
| next | Advances one line of source code in the current function without stepping into other functions. |
| print <i>EXPR</i> | Shows the value of the expression <i>EXPR</i> . |
| quit | Quits gdb. |
| run | Starts running the currently loaded executable. |
| set variable <i>VAR=VALUE</i> | Sets the value of the variable <i>VAR</i> to <i>VALUE</i> . |
| shell <i>CMD</i> | Executes the Unix command <i>CMD</i> , without leaving gdb. |
| step | Advances one line in the current function, stepping into other functions, if any. |
| watch <i>VAR</i> | Shows the value of the variable named <i>VAR</i> whenever the value changes. |
| where | Displays the call sequence. Use this command to locate where your program died. |
| <i>x/F ADDR</i> | Examines the contents of the memory location at address <i>ADDR</i> in the format specified by the letter <i>F</i> , which can be o (octal), x (hex), d (decimal), u (unsigned decimal), t (binary), f (float), a (address), i (instruction), c (char), or s (string). You can append a letter indicating the size of data type to the format letter. Size letters are b (byte), h (halfword, 2 bytes), w (word, 4 bytes), and g (giant, 8 bytes). Typically, <i>ADDR</i> is the name of a variable or pointer. |

Finding bugs by using gdb

To understand how you can find bugs by using gdb, you need to see an example. The procedure is easiest to show with a simple example, so the following, `dbgtst.c`, is a contrived program that contains a typical bug.

```
#include <stdio.h>
static char buf[256];
void read_input(char *s);
int main(void)
{
    char *input = NULL; /* Just a pointer, no storage for string */
    read_input(input);
}
```

```
/* Process command. */
printf("You typed: %s\n", input);
/* . . . */
return 0;
}
void read_input(char *s)
{
printf("Command: ");
gets(s);
}
```

This program's main function calls the `read_input` function to get a line of input from the user. The `read_input` function expects a character array in which it returns what the user types. In this example, however, `main` calls `read_input` with an uninitialized pointer — that's the bug in this simple program.

Build the program by using `gcc` with the `-g` option:

```
gcc -g -o dbgtst dbgtst.c
```

Ignore the warning message about the `gets` function being dangerous; I'm trying to use the shortcoming of that function to show how you can use `gdb` to track down errors.

To see the problem with this program, run it and type `test` at the `Command:` prompt:

```
./dbgtst
Command: test
Segmentation fault
```

The program dies after displaying the `Segmentation fault` message. For such a small program as this one, you can probably find the cause by examining the source code. In a real-world application, however, you may not immediately know what causes the error. That's when you have to use `gdb` to find the cause of the problem.

To use `gdb` to locate a bug, follow these steps:

1. Load the program under `gdb`.

For example, type `gdb dbgtst` to load a program named `dbgtst` in `gdb`.

2. Start executing the program under `gdb` by typing the `run` command. When the program prompts for input, type some input text.

The program fails as it did previously. Here's what happens with the `dbgtst` program:

```
(gdb) run
Starting program: /home/edulaney/swdev/dbgtst
Command: test
Program received signal SIGSEGV, Segmentation fault.
0x400802b6 in gets () from /lib/tls/libc.so.6
(gdb)
```

3. Use the `where` command to determine where the program died.

For the `dbgtst` program, this command yields this output:

```
(gdb) where
#0 0x400802b6 in gets () from /lib/tls/libc.so.6
#1 0x08048474 in read_input (s=0x0) at dbgtst.c:16
#2 0x08048436 in main () at dbgtst.c:7
(gdb)
```

The output shows the sequence of function calls. Function call #0 — the most recent one — is to the `gets` C library function. The `gets` call originates in the `read_input` function (at line 16 of the file `dbgtst.c`), which in turn is called from the `main` function at line 7 of the `dbgtst.c` file.

4. Use the `list` command to inspect the lines of suspect source code.

In `dbgtst`, you may start with line 16 of `dbgtst.c` file, as follows:

```
(gdb) list dbgtst.c:16
11 return 0;
12 }
13 void read_input(char *s)
14 {
15 printf("Command: ");
16 gets(s);
17 }
18
(gdb)
```

After looking at this listing, you can tell that the problem may be the way `read_input` is called. Then you list the lines around line 7 in `dbgtst.c` (where the `read_input` call originates):

```
(gdb) list dbgtst.c:7
2 static char buf[256];
3 void read_input(char *s);
4 int main(void)
5 {
6 char *input = NULL; /* Just a pointer, no storage for string */
7 read_input(input);
8 /* Process command. */
9 printf("You typed: %s\n", input);
10 /* . . . */
11 return 0;
(gdb)
```

At this point, you can narrow the problem to the variable named `input`. That variable is an array, not a `NULL` (which means zero) pointer.

Fixing bugs in gdb

Sometimes you can fix a bug directly in `gdb`. For the example program in the preceding section, you can try this fix immediately after the program dies after displaying an error message. An extra buffer named `buf` is defined in the `dbgtst` program, as follows:

```
static char buf[256];
```

We can fix the problem of the uninitialized pointer by setting the variable `input` to `buf`. The following session with `gdb` corrects the problem of the uninitialized pointer. (This example picks up immediately after the program runs and dies, due to the segmentation fault.)

```
(gdb) file dbgtst
A program is being debugged already. Kill it? (y or n) y
Load new symbol table from "/home/edulaney/sw/dbgtst"? (y or n) y
Reading symbols from /home/edulaney/sw/dbgtst . . . done.
(gdb) list
1 #include <stdio.h>
2 static char buf[256];
3 void read_input(char *s);
4 int main(void)
5 {
6 char *input = NULL; /* Just a pointer, no storage for string */
7 read_input(input);
8 /* Process command. */
9 printf("You typed: %s\n", input);
10 /* . . . */
(gdb) break 7
Breakpoint 2 at 0x804842b: file dbgtst.c, line 7.
(gdb) run
Starting program: /home/edulaney/sw/dbgtst
Breakpoint 1, main () at dbgtst.c:7
7 read_input(input);
(gdb) set var input=buf
(gdb) cont
Continuing.
Command: test
You typed: test
Program exited normally.
(gdb)q
```

As the preceding listing shows, if the program is stopped just before `read_input` is called and the variable named `input` is set to `buf` (which is a valid array of characters), the rest of the program runs fine.

After finding a fix that works in `gdb`, you can make the necessary changes to the source files and make the fix permanent.

Understanding the Implications of GNU Licenses

You have to pay a price for the bounty of Linux. To protect its developers and users, Linux is distributed under the GNU GPL (General Public License), which stipulates the distribution of the source code.

The GPL doesn't mean, however, that you can't write commercial software for Linux that you want to distribute (either for free or for a price) in binary form only. You can follow all the rules and still sell your Linux applications in binary form.

When writing applications for Linux, be aware of two licenses:

- ◆ The **GNU General Public License** (GPL), which governs many Linux programs, including the Linux kernel and GCC
- ◆ The **GNU Library General Public License** (LGPL), which covers many Linux libraries



The following sections provide an overview of these licenses and some suggestions on how to meet their requirements. Don't take anything in this book as legal advice. Instead, you should read the full text for these licenses in the text files on your Linux system, and then show these licenses to your legal counsel for a full interpretation and an assessment of their applicability to your business.

The GNU General Public License

The text of the GNU General Public License (GPL) is in a file named `COPYING` in various directories in your Linux system. For example, type the following command to find a copy of that file in your Linux system for various items:

```
find /usr -name "COPYING" -print
```

After you find the file, you can change to that directory and type `more COPYING` to read the GPL. These are examples of the license accompanying code, and you can find other examples at <http://www.gnu.org/copyleft/gpl.html>.

The GPL has nothing to do with whether you charge for the software or distribute it for free; its thrust is to keep the software free for all users. GPL requires that the software be distributed in source-code form, and stipulates that any user can copy and distribute the software in source-code form to anyone else. In addition, everyone is reminded that the software comes with absolutely no warranty.

The software that the GPL covers isn't in the public domain. Software covered by GPL is always copyrighted, and the GPL spells out the restrictions on the software's copying and distribution. From a user's point of view, of course, GPL's restrictions aren't really restrictions; the restrictions are benefits because the user is guaranteed access to the source code.



If your application uses parts of any software that the GPL covers, your application is considered a *derived work*, which means that your application is also covered by the GPL and you must distribute the source code to your application.

Although the GPL covers the Linux kernel, the GPL doesn't cover your applications that use the kernel services through system calls. Those applications are considered normal use of the kernel.

If you plan to distribute your application in binary form (as most commercial software is distributed), you must make sure that your application doesn't use any parts of any software the GPL covers. Your application may end up using parts of other software when it calls functions in a library. Most libraries, however, are covered by a different GNU license, which is described in the next section.

You have to watch out for only a few of the library and utility programs that the GPL covers. The GNU `dbm` (`gdbm`) database library is one of the prominent libraries that GPL covers. The GNU `bison` parser-generator tool is another utility that the GPL covers. If you allow `bison` to generate code, the GPL covers that code.



Other alternatives for the GNU `dbm` and GNU `bison` aren't covered by GPL. For a database library, you can use the Berkeley database library `db` in place of `gdbm`. For a parser-generator, you may use `yacc` instead of `bison`.

The GNU Library General Public License

The text of the GNU Library General Public License (LGPL) is in a file named `COPYING.LIB`. If you have the kernel source installed, a copy of `COPYING.LIB` file is in one of the source directories. To locate a copy of the `COPYING.LIB` file on your Linux system, type the following command in a terminal window:

```
find /usr -name "COPYING*" -print
```

This command lists all occurrences of `COPYING` and `COPYING.LIB` in your system. The `COPYING` file contains the GPL, whereas `COPYING.LIB` has the LGPL.

The LGPL is intended to allow use of libraries in your applications, even if you don't distribute source code for your application. The LGPL stipulates, however, that users must have access to the source code of the library you use — and that users can make use of modified versions of those libraries.

The LGPL covers most Linux libraries, including the C library (`libc.a`). Thus, when you build your application on Linux by using the GCC compiler, your application links with code from one or more libraries that the LGPL covers. If you want to distribute your application in only binary form, you need to pay attention to LGPL.



One way to meet the intent of the LGPL is to provide the object code for your application and a `makefile` that relinks your object files with any updated Linux libraries the LGPL covers.



A better way to satisfy the LGPL is to use *dynamic linking*, in which your application and the library are separate entities, even though your application calls functions that reside in the library when it runs. With dynamic linking, users immediately get the benefit of any updates to the libraries without ever having to relink the application.



The newest version of the license is GPLv3 and a Quick Guide to it can be found at: <http://www.gnu.org/licenses/quick-guide-gplv3.html>.

Book VIII

Linux Certification

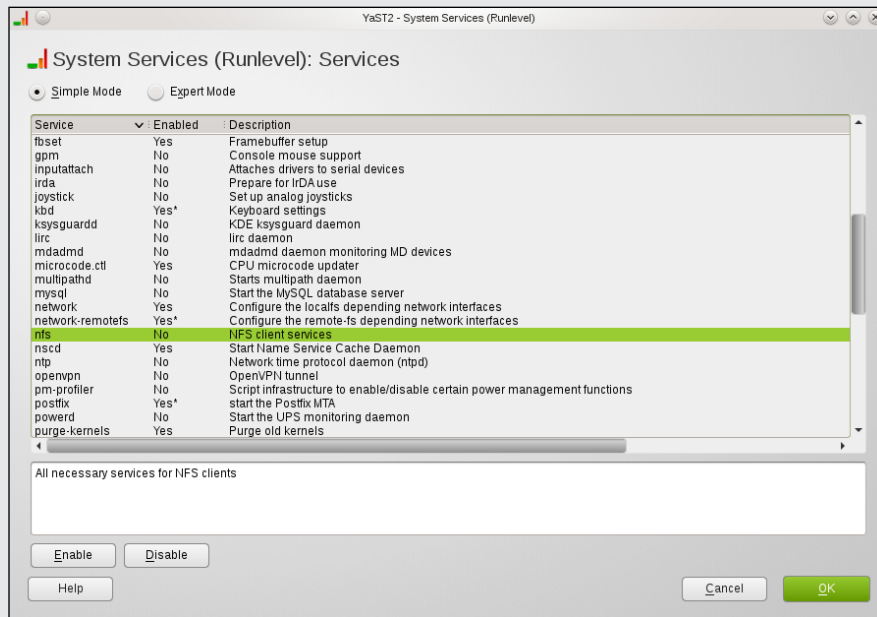

Visit www.dummies.com/extras/linuxaio for great Dummies content online.

Contents at a Glance

| | |
|--|------------|
| Chapter 1: Studying for the Linux Essentials Certification Exam . . . | 491 |
| Overview of Linux Essentials | 491 |
| The Linux Community and a Career in Open Source | 492 |
| Using the Command Line to Get Help | 493 |
| The Power of the Command Line | 495 |
| The Linux Operating System | 496 |
| Security and File Permissions | 498 |
| | |
| Chapter 2: Studying for the CompTIA Linux+ Powered by LPI Certification Exams | 501 |
| Overview of the CompTIA Linux+ Exams | 501 |
| System Architecture | 502 |
| Linux Installation and Package Management | 503 |
| GNU and Unix Commands | 505 |
| Devices, Linux File systems, Filesystem Hierarchy Standard | 507 |
| Shells, Scripting, and Data Management..... | 509 |
| User Interfaces and Desktops..... | 510 |
| Administrative Tasks | 511 |
| Essential System Services | 512 |
| Networking Fundamentals | 514 |
| Security | 515 |
| | |
| Chapter 3: Other Linux Certifications | 517 |
| Vendor-Neutral Certifications..... | 517 |
| Vendor-Specific Certifications | 518 |

Chapter 1: Studying for the Linux Essentials Certification Exam

In This Chapter

- ✓ Getting an overview of the Linux Essentials Exam
- ✓ Looking at the details of each domain

Just as there are many levels of degree attainment you can achieve through an educational institution (associate's degree, bachelor's, master's, doctorate), there are multiple levels of Linux certification available. This book is written primarily for the Linux+ certification from CompTIA and the LPI LX0-101 and LX0-102 exams. As such, it covers everything you need to know to study and pass LPI's lower-level certification, known as Linux Essentials.

The following sections provide an overall look at the exam, and then explore the topics beneath each of the domains.

Overview of Linux Essentials

The Linux Essentials Certificate of Achievement was created by the Linux Professional Institute (LPI) to appeal to the academic sector. Students taking classes in Linux may not get through all the topics necessary to pass the two exams (LX0-101 and LX0-102) to gain the Level 1 certification, but LPI still wanted to recognize and authenticate their knowledge. This program was created through international collaboration with a classroom focus in mind. As of this writing, the program is live in Europe, the Middle East, and Africa, with plans to roll out to other regions in the near future.



Linux Essentials is a certificate of achievement, intended to be a much lower-level (subset) certification than the Level 1 certification. Although Linux Essentials is recommended, it's not required for any of the LPIC professional certifications.

There are five domains (called Topics) on the exam; Table 1-1 shows them, along with the weighting for each.

| <i>Topic</i> | <i>Weighting</i> |
|---|------------------|
| The Linux Community and a Career in Open Source | 7 |
| Finding Your Way on a Linux System | 8 |
| The Power of the Command Line | 10 |
| The Linux Operating System | 8 |
| Security and File Permissions | 7 |

The sections that follow look at each of these topics in more detail.

The Linux Community and a Career in Open Source

Table 1-2 shows the subtopics, weight, description, and key knowledge areas for this topic.

| <i>Subtopic</i> | <i>Weight</i> | <i>Description</i> | <i>Key Areas</i> |
|--|---------------|--|--|
| Linux Evolution and Popular Operating Systems | 2 | Knowledge of Linux development and major distributions | Open source philosophy; distributions; embedded systems |
| Major Open Source Applications | 2 | Awareness of major applications and their uses | Desktop applications; server applications; mobile applications; development languages; package management tools and repositories |
| Understanding Open Source Software and Licensing | 1 | Open communities and licensing Open Source Software for business | Licensing; Free Software Foundation (FSF), Open Source Initiative (OSI) |
| ICT Skills and Working in Linux | 2 | Basic Information and Communication Technology (ICT) skills and working in Linux | Desktop skills; getting to the command line; industry uses of Linux, cloud computing and virtualization |

To adequately address these topics, focus on these files, terms, and utilities: Android; Apache; Audacity; Blender; BSD; C; CentOS; Creative Commons; Debian; DHCP; DNS; Firefox; FLOSS; FOSS; Gimp; GPR; ImageMagick; LibreOffice; MySQL; NFS; OpenLDAP; OpenOffice.org; Password issues; Perl; PHP; Python; Postfix; PostgreSQL; Privacy issues and tools; Samba; Shell; Terminal and Console; and Thunderbird.

In addition, focus on these topics: Use of common open source applications in presentations and projects; using a browser; privacy concerns; configuration options; searching the web; and saving content.

Here are the top ten items to know as you study for this domain:

1. Linux is the best-known example of open source software so far developed (and still in development).
2. The shell is the command interpreter that resides between the user and the operating system. While a number of shells are available, the most common today is the `bash` shell.
3. A plethora of applications and tools is available for use with the various Linux distributions. Many of these tools are also open source.
4. The Apache Software Foundation distributes open source software under the Apache license that is Free and Open Source (FOSS).
5. The Free Software Foundation (FSF) supports the free (open source) software movement and copyleft under the GNU General Public License. *Copyleft* makes it possible for modifications to be made to software while preserving the same rights in the produced derivatives.
6. The Open Source Initiative (OSI) also supports the open source software movement, as does the GNOME Foundation, Ubuntu Foundation, and many other organizations.
7. OpenOffice.org was a popular suite of open source office productivity software. LibreOffice is a fork of OpenOffice that has eclipsed it in popularity.
8. Samba makes it possible for Linux systems to share files with Windows-based systems.
9. Thunderbird is a popular mail and news client originally created by the Mozilla Foundation.
10. A number of web browsers are available for Linux. The most popular currently is Firefox.

Using the Command Line to Get Help

Table 1-3 shows the subtopics, weight, description, and key knowledge areas for this topic.

| Table 1-3 | | Breakout of Topic 2 | |
|--------------------------------------|---------------|--|---|
| <i>Subtopic</i> | <i>Weight</i> | <i>Description</i> | <i>Key Areas</i> |
| Command Line Basics | 2 | Basics of using the Linux command line | Basic shell; Formatting commands; Working with options; Variables; Globbing; Quoting |
| Using the Command Line to Get Help | 2 | Running help commands and navigation of the various help systems | man files; info command |
| Using Directories and Listing Files | 2 | Navigation of home and system directories and listing files in various locations | Files, directories; hidden files and directories; home directory; absolute and relative paths |
| Creating, Moving, and Deleting Files | 2 | Create, move, and delete files under the home directory | Files and directories; case sensitivity; simple globbing and quoting |

To adequately address these topics, focus on these files, terms, and utilities: `&&`; `.` and `..`; `/usr/share/doc`; `||`; `apropos`; `cd`; common options for `ls`; `cp`; `echo`; `history`; Home and `~`; `info`; `locate`; `man`; `man` pages; `mkdir`; `mv`; `PATH` env variable; recursive listings; `rm`; `rmdir`; substitutions; `touch`; `whatis`; `whereis`; and `which`.

Here are the top ten items to know as you study for this domain:

1. Regular expressions – often referred to as *globbing* – can be used with the shells available in Linux to match wildcard characters. Among the possible wildcards, the asterisk (*) will match any number of characters; the question mark (?) will match only one character.
2. Linux is a case-sensitive operating system.
3. Files can be “hidden” by preceding their names with a single period (.). In pathnames, however, a single period (.) specifies this directory and two periods (..) signifies the parent directory.
4. Absolute paths give the full path to a resource, while relative paths give directions from where you are currently working. An example of an absolute path would be `/tmp/eadulaney/file` whereas a relative link would be `../file`.

5. Files can be copied using `cp` or moved using `mv`. Files can be deleted with `rm` and directories (which are created with `mkdir`) can be removed with `rmdir`. Recursive deletion can be done with `rm -r`.
6. To change directories, use the `cd` command. When used without parameters, this will move you to your home directory. To see what directory you are presently working in, use the `pwd` (present working directory) command.
7. The `ls` command has a plethora of options to allow you to list files. The `-a` option will list all (including hidden) files.
8. Help is available through the manual pages (accessed with the `man` command) and `info` (which shows help files stored beneath `/user/info`).
9. The `whatis` command shows what manual pages are available for an entry while `whereis` shows the location of the file and all related files (including any manual pages).
10. Many standard utilities allow you to enter the name of the executable followed by `--help` to obtain help only on the syntax.

The Power of the Command Line

Table 1-4 shows the subtopics, weight, description, and key knowledge areas for this topic.

| Table 1-4 | | Breakout of Topic 3 | |
|--|--------|--|---|
| Subtopic | Weight | Description | Key Areas |
| Archiving Files on the Command Line | 2 | Archiving files in the user home directory | Files, directories; archives, compression |
| Searching and Extracting Data from Files | 4 | Search and extract data from files in the home directory | Command line pipes; I/O re-direction |
| Turning Commands into a Script | 4 | Turning repetitive commands into simple scripts | Basic text editing; basic shell scripting |

To adequately address these topics, focus on the following files, terms, and utilities: `/bin/sh`; arguments; `bash`; `bzip2`; `case`; common `tar` options; `cut`; exit status; extracting individual files from archives; `find`; `for` loops; `grep`; `gzip`; `head`; `if`; `less`; `nano`; Partial POSIX Basic Regular Expressions

([[^]],[^],^{\$}); Partial POSIX Extended Regular Expressions (+, (), |); pico; read; sort; tail; tar; test; unzip; variables; vi; wc; while; xargs; and zip.

Here are the top ten items to know as you study for this domain:

1. Standard input (`stdin`) is traditionally the keyboard and standard output (`stdout`) is traditionally the monitor. Both can be redirected, as can standard error (`stderr`) using the symbols `>`, `>>`, `<`, and `|`.
2. Commands can be joined on the command line by the semicolon (`;`) and each command will run independent of each other. You can also use the pipe (`|`) to send the output of one command as the input of another command.
3. The `cut` command can pull fields from a file and they can be combined using either `paste` or `join`. The latter offers more features than the former and can be used with conditions.
4. The `wc` command can count the number of lines, words, and characters in a file.
5. The `grep` utility (and its counterparts `egrep` and `fgrep`) can be used to find matches for strings within files.
6. The `find` command can be used to search the system for files/directories that meet any number of criteria. When these entities are found, the `xargs` command can be used to look deeper within them for other values (such as in conjunction with `grep`).
7. You can use the `tar` command (which can combine multiple files into a single archive) to do backups.
8. In addition to archiving, you can also compress files with the `gzip` or `pack` commands. To uncompress files, use `uncompress`, `gunzip`, or `unpack`.
9. Variables can be given at the command line and referenced as `$1`, `$2`, and so on, or entered into the executing file with the `read` command.
10. Logic can be added to scripts by testing conditions with `test` or `[`. Commands can execute using `if-then-fi` deviations or through looping (`while`, `until`, or `for`). You can use the `exit` command to leave a script or use `break` to leave a loop.

The Linux Operating System

Table 1-5 shows the subtopics, weight, description, and key knowledge areas for this topic.

| Table 1-5 | | Breakout of Topic 4 | |
|---------------------------------|---------------|--|--|
| <i>Subtopic</i> | <i>Weight</i> | <i>Description</i> | <i>Key Areas</i> |
| Choosing an Operating System | 1 | Knowledge of major operating systems and Linux distributions | Windows, Mac, Linux differences; distribution lifecycle management |
| Understanding computer hardware | 2 | Familiarity with the components that go into building desktop and server computers | Hardware |
| Where Data is Stored | 3 | Where various types of information are stored on a Linux system | Kernel; processes; syslog; klog; dmesg; /lib; /usr/lib; /etc; /var/log |
| Your Computer on the Network | 2 | Querying vital networking settings and determining the basic requirements for a computer on a local area network (LAN) | Internet; network; routers; Domain Name Service; network configuration |

To adequately address these topics, focus on the following files, terms, and utilities: desktop configuration (GUI versus command line); `dig`; display types; drivers; `free`; hard drives and partitions; `ifconfig`; IPv4; IPv6; libraries; maintenance cycles (beta and stable); memory addresses; motherboards; `netstat`; optical drives; peripherals; `ping`; power supplies; processes and process tables; processors; system messaging and logging; programs; packages and package databases; `ps`; `resolv.conf`; `route`; `ssh`; system configuration; and `top`.

Here are the top ten items to know as you study for this domain:

1. When run, every command spans at least one process; processes can be viewed with `ps` or `top` (which updates the display dynamically).
2. Jobs can run in the foreground or background and be moved between the two. Jobs running in the foreground can be suspended by pressing `Ctrl+Z`.

3. IPv4 uses 32-bit addresses, each divided into four octets. The first octet identifies the class of address (A, B, C). The address can be public or private.
4. The `ifconfig` utility can be used to see the current IP configuration of the network cards.
5. The `ping` utility is an all-purpose tool for testing connectivity. It sends echo messages to a specified host to see whether that host can be reached. You can use `ping` with the loopback address (127.0.0.1) to test internal configuration.
6. The `route` utility displays the routing table and allows you to configure it.
7. The `netstat` utility shows the current status of ports – those that are open, listening, and so on.
8. The system log is `/var/log/messages` and this is where the majority of events are written to by the system log daemon (`syslogd`). Messages routed there can be viewed with the `dmesg` command.
9. The `logrotate` command can be used to automatically archive log files and perform maintenance as configured in `/etc/syslog.conf`.
10. You can manually write entries to log files using the `logger` command.

Security and File Permissions

Table 1-6 shows the subtopics, weight, description, and key knowledge areas for this topic.

| Table 1-6 | | Breakout of Topic 5 | |
|---|---------------|--|---|
| <i>Subtopic</i> | <i>Weight</i> | <i>Description</i> | <i>Key Areas</i> |
| Basic Security and Identifying User Types | 2 | Various types of users on a Linux system | Root and standard users; system users |
| Creating Users and Groups | 2 | Creating users and groups on a Linux system | User and group commands; user IDs |
| Managing Files Permissions and Ownership | 2 | Understanding and manipulating file permissions and ownership settings | File/directory permissions and owners |
| Special Directories and Files | 1 | Special directories and files on a Linux system, including special permissions | System files; libraries; symbolic links |

To adequately address these topics, focus on the following files, terms, and utilities: `/etc`; `/etc/group`; `/etc/passwd`; `/etc/shadow`; `/tmp`; `/var`; `/var/tmp`; `chgrp`; `chmod`; `chown`; `groupadd`; `groupdel`; `groupmod`; **hard links**; `id`; `last`; `ls -d`; `ls -l`; `ls -s`; `passwd`; `setgid`; `setuid`; **sticky bit**; `su`; `sudo`; `useradd`; `userdel`; `usermod`; `w`; and `who`.

Here are the top ten items to know as you study for this domain:

1. File and directory permissions can be changed with the `chmod` command (which accepts numeric and symbolic values).
2. Adding 1000 to standard permissions turns on the “sticky bit”; adding 2000 turns on the `SGID` permission. Adding 4000 turns on the `SUID` permission.
3. Links are created with the `ln` command. A “hard” link is nothing more than an alias to a file (sharing the same inode). The `ln -s` command creates a symbolic link that is an actual file with its own inode. The symbolic link contains a pointer to the original file and can span across file systems; the hard link cannot.
4. User accounts can be added by manually editing the configuration files or by using the `useradd` command; they can be removed with `userdel`.
5. The `groupadd` utility can be used to create groups and `groupdel` can be used to remove groups. Groups can be modified with `groupmod` and users can change from one group to another with the `newgrp` command.
6. Passwords are changed with the `passwd` command. Older systems stored passwords in `/etc/passwd`; now passwords are stored in `/etc/shadow`, where they are more secure.
7. To see who logged on most recently and may currently still be on the network, you can use the `last` command.
8. The `su` command allows you to become another user (returning with `exit`). If no other username is specified, then the root user is implied, hence the `su` for superuser.
9. Use `sudo` instead of `su` when you want to run a command as another user (usually `root`) without becoming that user.
10. The `who` command shows who is logged on; the `w` command shows information combining `who` with `uptime`.

Chapter 2: Studying for the CompTIA Linux+ Powered by LPI Certification Exams

In This Chapter

- ✓ Getting an overview of the CompTIA Linux+ Exams
- ✓ Looking into each domain in depth

The previous chapter examines the Linux Essentials exam – LPI’s lower-level certification. That certification should be viewed as a steppingstone to a higher-level exam. The Linux+ certification exam from CompTIA – consisting of the LPI LX0-101 and LX0-102 exams – is an ideal example of such a high-level test.

In the following sections, we provide an overview of the two exams and then explore the topics beneath each of the domains.

Overview of the CompTIA Linux+ Exams

The official name of the certification in question is “CompTIA Linux+ Powered by LPI” and although that’s a mouthful to say, it’s also a meaningful addition to a résumé. The certification is awarded by CompTIA; it consists of two exams by the Linux Professional Institute (LPI): LX0-101 and LX0-102. Accordingly, at the time of taking the exams, a candidate can choose to have the test scores forwarded to LPI — and gain the Level 1 certification (LPIC-1) at the same time.



Records are separately maintained by LPI and CompTIA. If you choose not to forward your scores, you can be Linux+-certified but not LPIC-1 certified.

Each of the two exams consists of 60 questions that must be answered in 90 minutes. The passing score is 500 on a scale from 200 to 800, and it is highly recommended – but not required – that candidates have 12 months of Linux administration experience.

There are four domains on one exam and six on the other. Table 2-1 shows the domains on each, along with their prospective weighting.

| <i>Exam</i> | <i>Domain</i> | <i>Weighting</i> |
|-------------|--|------------------|
| LX0-101 | 101 System Architecture | 14% |
| | 102 Linux Installation and Package Management | 18% |
| | 103 GNU and Unix Commands | 43% |
| | 104 Devices, Linux Filesystems, Filesystem Hierachy Standard | 25% |
| LX0-102 | 105 Shells, Scripting, and Data Management | 17% |
| | 106 User Interfaces and Desktops | 8% |
| | 107 Administrative Tasks | 20% |
| | 108 Essential System Services | 17% |
| | 109 Networking Fundamentals | 23% |
| | 110 Security | 15% |

The sections that follow look at each of these topics in more detail.

System Architecture

Table 2-2 shows the subtopics, weights, descriptions, and key knowledge areas for this topic.

| <i>Subtopic</i> | <i>Weight</i> | <i>Description</i> | <i>Key Areas</i> |
|--|---------------|--|--|
| Determine and configure hardware settings | 2 | Conceptual understanding of kernel loading options and boot steps | Working with peripherals, storage devices, and the tools you use to configure them |
| Boot the system | 3 | How to walk through the boot process | Common boot commands; the boot sequence; boot logs |
| Change run levels and shut down or reboot system | 3 | Changing to single-user mode, shutting down and rebooting the system. Knowing that you should alert users to changes in run level and to the need for properly terminating processes | Default run level; changing run levels; how to terminate |

To adequately address these topics, focus on the following files, terms, and utilities: `/dev`, `/etc/init.d`, `/etc/inittab`, `/proc`, `/sys`, `/var/log/messages`, BIOS, boot loader, `dmesg`, `init`, `kernel`, `lsmod`, `lspci`, `lsusb`, `modprobe`, `shutdown`, and `telinit`.

Here are the top ten items to know as you study for this domain:

1. The system log is `/var/log/messages` and this is where the majority of events are written to by the system log daemon (`syslogd`). Messages routed there can be viewed with the `dmesg` command.
2. The `logrotate` command can be used to automatically archive log files and perform maintenance as configured in `/etc/syslog.conf`.
3. You can manually write entries to log files using the `logger` command.
4. The `init` daemon is responsible for maintaining proper running of daemons at specified run levels. The system attempts to go to the run level specified as the default in the `/etc/inittab` file upon each boot.
5. Run levels can be changed with the `init` and `shutdown` commands.
6. Valid run levels defined as standards are: 0 (power off), 1 (single-user mode), 2 (multiple user without NFS), 3 (multiple user with NFS), 5 (X environment), and 6 (reboot).
7. The `lsmod` command is used to list loaded modules. The `insmod` command is used to install a module. The `rmmmod` command is used to remove a module from the system. The `modinfo` command will show information about a module.
8. The `modprobe` utility can probe and install a module and its dependents, while the `depmod` utility will determine and show any module dependencies that exist.
9. Kernel software is typically named `linux-x.y.z` where `x.y.z` represents the version number.
10. The `make config` command executes a command-line-oriented view and allows you to respond interactively with the kernel build.

Linux Installation and Package Management

Table 2-3 shows the subtopics, weights, descriptions, and key knowledge areas for this topic.

| Table 2-3 | | Breakout of Domain 102 | |
|------------------------------------|---------------|---|--|
| <i>Subtopic</i> | <i>Weight</i> | <i>Description</i> | <i>Key Areas</i> |
| Design hard disk layout | 2 | Designing a disk-partitioning scheme for a Linux system | Allocating file systems and swap space, tailoring the design to the intended use of the system |
| Install a boot manager | 2 | Select, install, and configure a boot manager | Boot loaders; GRUB and GRUB 2 |
| Manage shared libraries | 1 | Determine the shared libraries that executable programs depend on and install them when necessary | Shared library locations and how to load |
| Use Debian package management | 3 | Know the Debian package tools | Install, upgrade, and uninstall Debian binary packages |
| Use RPM and Yum package management | 3 | Know the RPM and Yum tools | Install, upgrade, and remove packages with RPM and Yum |

To adequately address these topics, focus on the following files, terms, and utilities: / (root) file system, /boot/grub/menu.lst, /etc/apt/sources.list, /etc/ld.so.conf, /etc/yum.conf, /etc/yum.repos.d/, /home file system, /var file system, apt-cache, apt-get, aptitude, dpkg, dpkg-reconfigure, grub-install, LD_LIBRARY_PATH, ldconfig, ldd, MBR, mount points, partitions, rpm, rpm2cpio, superbloc, swap space, yum, yumdownloader.

Here are the top ten items to know as you study for this domain:

1. The `ldd` command is used to see what shared libraries a program is dependent upon.
2. The `ldconfig` command is used to update and maintain the cache of shared library data. You can see the current cache by using the command `ldconfig -p`.
3. Popular package managers include Red Hat's Package Manager (RPM) and Debian's (dpkg). The purpose of both is to simplify working with software.

4. Options available with RPM include `-i` (for installing packages), `-e` (for removing packages), `-q` (for querying what packages belong to what files), `-b` (for building a package), and `-p` (to print/display information).
5. With `dpkg`, you use the `dselect` command to use the graphical interface. You can also use command-line options that include `-i` (to install packages), `-l` (to list information about the package), `-r` (to remove the package), and `-c` (to list all files in the package).
6. The Advanced Packaging Tool (APT) was designed as a front end for `dpkg` but now works with both `.deb` and `.rpm` packages.
7. The Yellow dog Updater, Modified is more commonly known as `Yum` and can be used at the command line to download RPM packages.
8. The superblock contains information about the type of file system, the size, status, and metadata information.
9. The GRUB bootloader (an acronym for GNU's Grand Unified Bootloader) allows multiple operating systems to exist on the same machine and a user to choose which one they want to boot on startup. The latest version is GRUB 2.
10. Linux uses both a swap partition and a swap file for swap space. The `swapon` command can be used to toggle designated swap space on and off. Areas for swap space can be created with `mkswap`.

GNU and Unix Commands

Table 2-4 shows the subtopics, weights, descriptions, and key knowledge areas for this topic.

| Table 2-4 | | Breakout of Domain 103 | |
|------------------------------------|--------|--|---|
| Subtopic | Weight | Description | Key Areas |
| Work on the command line | 4 | Interact with shells and commands using the command line and the <code>bash</code> shell | Use single shell commands and one-line command sequences as well as modify the shell environment and use/edit command history |
| Process text streams using filters | 3 | Apply filters to text streams | Send text files and output streams through text utility filters |
| Perform basic file management | 4 | Use the basic Linux commands to manage files and directories | Copy, move, and delete files and directories individually and recursively |

(continued)

Table 2-4 (continued)

| <i>Subtopic</i> | <i>Weight</i> | <i>Description</i> | <i>Key Areas</i> |
|---|---------------|---|---|
| Use streams, pipes, and redirects | 4 | Redirect streams and connect them – including standard output, standard input, and standard error | Pipe the output of one command to the input of another |
| Create, monitor, and kill processes | 4 | Perform basic process management | Run jobs in the foreground and background; send signals to processes |
| Modify process execution priorities | 2 | Manage process execution priorities | Run programs with higher and lower priorities than the default |
| Search text files using regular expressions | 2 | Understand regular expressions and how to use them | Create simple regular expressions and perform searches |
| Perform basic file editing operations using <code>vi</code> | 3 | Understand <code>vi</code> navigation, editing, copying, deleting, etc. | Use basic <code>vi</code> modes to insert, edit, copy, delete, and find text. |

To adequately address these topics, focus on the following files, terms, and utilities: `&`, `.`, `bash`, `bg`, `bzip2`, `cat`, `cp`, `cpio`, `cut`, `dd`, `echo`, `egrep`, `env`, `exec`, `expand`, `export`, `fg`, `fgrep`, `file`, `file globbing`, `find`, `fmt`, `free`, `grep`, `gunzip`, `gzip`, `head`, `history`, `jobs`, `join`, `kill`, `killall`, `ls`, `man`, `mkdir`, `mv`, `nice`, `nl`, `nohup`, `od`, `paste`, `pr`, `ps`, `pwd`, `regex (7)`, `renice`, `rm`, `rmdir`, `sed`, `set`, `sort`, `split`, `tail`, `tar`, `tee`, `top`, `touch`, `tr`, `uname`, `unexpand`, `uniq`, `unset`, `uptime`, `vi`, `wc`, and `xargs`.

Here are the top ten items to know as you study for this domain:

1. When run, every command spans at least one process and processes can be viewed with `ps` or `top` (which continues to update the display dynamically).
2. Jobs can run in the foreground or background and be moved between the two. Jobs running in the foreground can be suspended by pressing `Ctrl+Z`.
3. Files can be copied using `cp` or moved using `mv`. Files can be deleted with `rm` and directories (which are created with `mkdir`) can be removed with `rmdir`. Recursive deletion can be done with `rm -r`.
4. To change directories, use the `cd` command. When used without parameters, this will move you to your home directory. To see what directory you are presently working in, use the `pwd` (present working directory) command.

5. The `ls` command has a plethora of options to allow you to list files. The `-a` option will list all (including hidden) files.
6. The `cut` command can pull fields from a file and they can be combined using either `paste` or `join`. The latter offers more features than the former and can be used with conditions.
7. The `wc` command can count the number of lines, words, and characters in a file.
8. The `grep` utility (and its counterparts `egrep` and `fgrep`) can be used to find matches for strings within files.
9. The `find` command can be used to search the system for files/directories that meet any number of criteria. When these entities are found, the `xargs` command can be used to look deeper within them for other values (such as in conjunction with `grep`).
10. It's possible to convert data from one value to another by using a number of utilities. The most popular would include the `tr` (translate) utility and `sed` (the stream editor).

Devices, Linux File Systems, Filesystem Hierarchy Standard

Table 2-5 shows the subtopics, weights, descriptions, and key knowledge areas for this topic.

| Table 2-5 | | Breakout of Domain 104 | |
|---|---------------|---|---|
| <i>Subtopic</i> | <i>Weight</i> | <i>Description</i> | <i>Key Areas</i> |
| Create partitions and file-systems | 2 | Configure disk partitions | Use various <code>mkfs</code> commands to set-up partitions and create file-systems |
| Maintain the integrity of file-systems | 2 | Maintain a standard file-system and the extra data associated with journaling | File-system monitoring, integrity, and repair |
| Control mounting and unmounting of file-systems | 3 | Configure the mounting of file-systems | Manually mount and unmount and configure removable file-systems |
| Manage disk quotas | 1 | Manage user quotas | Configure quotas, edit and check reports |

(continued)

Table 2-5 (continued)

| <i>Subtopic</i> | <i>Weight</i> | <i>Description</i> | <i>Key Areas</i> |
|---|---------------|--|--|
| Manage file permissions and ownership | 3 | Control file access with permissions and ownership | Change the file-creation mask, work with special files |
| Create and change hard and symbolic links | 2 | Manage links to a file | Use links to support system administration |
| Find system files and place files in the correct location | 2 | Filesystem Hierarchy Standard (FHS) | Correct location of files and the purpose of important directories |

To adequately address these topics, focus on the following files, terms, and utilities: `/etc/fstab`, `/etc/updated.conf`, `/media`, `chgrp`, `chmod`, `chown`, `debugfs`, `df`, `du`, `dump32fs`, `e2fsck`, `edquota`, `ext2/ext3/ext4`, `find`, `fsck`, `ln`, `locate`, `mke2fs`, `mkfs`, `mkswap`, `mount`, `quota`, `quotaon`, `reiserfs v3`, `repquota`, `tune2fs`, `type`, `umask`, `umount`, `updated`, `vfat`, `whereis`, `which`, `xfstools`

Here are the top ten items to know as you study for this domain:

1. File and directory permissions can be changed with the `chmod` command (which accepts numeric and symbolic values).
2. The owner of a group can be changed with the `chown` command whereas the `chgrp` command allows changing the group associated with a file.
3. The `du` command can show how much of a disk is used.
4. The `df` command shows how much of a disk is free.
5. The main tool for troubleshooting disk issues is `fsck` which can check file-system structure, including inodes.
6. To mount file-systems, use the `mount` command and to unmount them use `umount`. To have mounting occur automatically at startup, add the entries to `/etc/fstab`.
7. Quotas can restrict the amount of space users or groups can use on the disk. Quotas are initialized with the `quota` command and they are toggled on and off with `quotaon` and `quotaoff`. They can be changed with `edquota` and reports can be generated with `repquota`.
8. When files are first created, the default permissions are equal to 666 minus any `umask` values. The default permissions for directories is equal to 777 minus any `umask` values.
9. The `mke2fs` utility can be used to make the file-system.
10. Linux supports numerous file-systems including `ext2`, `ext3`, `ext4`, and `reiserfs`.

Shells, Scripting, and Data Management

Table 2-6 shows the subtopics, weights, descriptions, and key knowledge areas for this topic — the first of the 102 exam.

| <i>Subtopic</i> | <i>Weight</i> | <i>Description</i> | <i>Key Areas</i> |
|---|---------------|--|---|
| Customize and use the shell environment | 4 | Be able to modify global and user profiles | Set environment variables and work within bash |
| Customize or write simple scripts | 4 | Customize existing bash scripts and write new ones | Be able to write code that includes loops and tests |
| SQL data management | 2 | Query databases and manipulate data with SQL | Know basic SQL commands |

To adequately address these topics, focus on the following files, terms, and utilities: `/etc/profile`, `~/.bash_login`, `~/.bash_logout`, `~/.bash_profile`, `~/.bashrc`, `~/.profile`, `alias`, `delete`, `env`, `export`, `for`, `from`, `function`, `group by`, `if`, `insert`, `join`, `lists`, `order by`, `read`, `select`, `seq`, `set`, `test`, `unset`, `update`, `where`, and `while`.

Here are the top ten items to know as you study for this domain:

1. Logic can be added to scripts by testing conditions with `test` or `[`. Commands can execute using `if-then-fi` deviations or through looping (`while`, `until`, or `for`). You can leave a script with the `exit` command or leave a loop with `break`.
2. Variables can be given at the command line and referenced as `$1`, `$2`, and so on, or entered into the executing file with the `read` command.
3. The `alias` command can be used to create an alias for a command to operate by another name (for example, being able to type `dir` and have `ls -l` performed).
4. Environmental variables can be viewed with the `env` command.
5. Variables can be added to the environment using the `set` command and `export`; they are removed using `unset`.
6. The `/etc/profile` configuration file is executed whenever a user logs in.
7. For those using the `bash` shell, the shell first looks for `.bash_profile`; if it does not file that profile, it looks for `.bash_login`.
8. When the `bash` user logs out, the shell will look for `.bash_logout` and execute any commands found there.

9. While other configuration files run only when the user logs in or out, the `.bashrc` file can execute each time a shell is run.
10. Shell scripts must have executable permissions to run, or be called by a shell (for example: `sh script`). The normal exit status of any script or application is 0 and anything else signifies a non-normal exit.

User Interfaces and Desktops

Table 2-7 shows the subtopics, weights, descriptions, and key knowledge areas for this topic.

| Table 2-7 | | Breakout of Domain 106 | |
|---------------------------|---------------|---|---|
| <i>Subtopic</i> | <i>Weight</i> | <i>Description</i> | <i>Key Areas</i> |
| Install and configure X11 | 2 | Be able to install and configure X11 | Basic understanding of X Window configuration |
| Set up a display manager | 2 | Set up and customize a display manager | Work with XDM (X Display Manager), GDM (Gnome Display Manager), and KDM (KDE Display Manager) |
| Accessibility | 1 | Knowledge and awareness of accessibility technologies | Assistive Technology (ATs) and keyboard settings |

To adequately address these topics, focus on the following files, terms, and utilities: `/etc/initab`, `/etc/x11/xorg.conf`, braille display, DISPLAY, emacspeak, gdm configuration files, gestures, GOK, high contrast desktop themes, kdm configuration files, large screen desktop themes, mouse keys, on-screen reader, orca, screen magnifier, screen reader, slow/bounce/toggle keys, sticky/repeat keys, X, xdm configuration files, xdpynfo, xhost, xwininfo

Here are the top ten items to know as you study for this domain:

1. The emacspeak speech interface is one of the most popular speech interfaces available for Linux.
2. The `xdpyinfo` utility can be used to view information about an X server. It can be used with the `all` option to see information about all the extensions supported by the server.
3. Window information for X can be viewed with the `xwininfo` utility. Using the `-all` option shows all the possible information.

4. The server access-control program for X is `xhost`. This is used to connect to a host across the network and work within the graphical interface.
5. The X Display Manager (XDM) is the default display manager included with the X Window System.
6. The `/etc/x11/xorg.conf` file is the X configuration file used for initial setup.
7. Several assistive technology projects have been developed for both KDE (the KDE Accessibility Project) and GNOME (the GNOME Accessibility Projects).
8. Orca is a screen reader from the GNOME project intended to help individuals who are blind or impaired. Orca will work with Firefox, Thunderbird, OpenOffice.org/LibreOffice, and other applications.
9. The GNOME onscreen keyboard reader (GOK) is another assistive technology. It works with XML files and can dynamically create keyboards to adapt to a user's needs.
10. *Slow keys* can be configured for a keyboard preference to accept input only if a key is held; this prevents accidental presses from counting as input. *Bounce keys* can be configured to ignore fast duplicate key presses; *sticky keys* can be used to simulate simultaneous key presses.

Administrative Tasks

Table 2-8 shows the subtopics, weights, descriptions, and key knowledge areas for this topic.

| <i>Subtopic</i> | <i>Weight</i> | <i>Description</i> | <i>Key Areas</i> |
|---|---------------|--|---|
| Manage user and group accounts and related system files | 5 | Add, remove, suspend, and change user accounts | Work with user and group accounts — including those for special purposes and limited accounts |
| Automate system administration tasks by scheduling jobs | 4 | Use <code>cron</code> and <code>anacron</code> | Run jobs at regular intervals and at specific times |
| Localization and Internationalization | 3 | Localize a system in a language other than English | Understand why <code>LANG=C</code> is useful in scripts |

To adequately address these topics, focus on the following files, terms, and utilities: `/etc/at.allow`, `/etc/at.deny`, `/etc/cron`, `/etc/cron.allow`, `/etc/cron.deny`, `/etc/crontab`, `/etc/group`, `/etc/localtime`, `/etc/passwd`, `/etc/shadow`, `/etc/skel`, `/etc/timezone`, `/usr/bin/locale`, `/usr/share/zoneinfo`, `/var/spool/cron/*`, ASCII, `at`, `atq`, `atrm`, `chage`, `crontab`, `date`, environment variables, `groupadd`, `groupdel`, `groupmod`, `iconv`, ISO-8859, `passwd`, `tzconfig`, `tzselect`, Unicode, `useradd`, `userdel`, `usermod`, and UTF-8.

Here are the top ten items to know as you study for this domain:

1. Users can be added by manually editing the configuration files or by using the `useradd` command (and they can be removed with `userdel`).
2. The `groupadd` utility can be used to create groups and `groupdel` can be used to remove groups. Groups can be modified with `groupmod` and users can change between groups with the `newgrp` command.
3. To schedule a job to run only once in unattended mode, you can use the `at` command.
4. Scheduled jobs can be viewed with the `atq` command and deleted prior to execution with `atrm`.
5. Restrictions can be placed on who can use the `at` service (`atd`) by creating an `at.allow` file and only placing valid usernames beneath it.
6. You can create an `at.deny` file – instead of `at.allow` – and place in it the names of users who cannot use that `at` service (meaning that everyone not listed in there can still use it).
7. If you need to schedule an unattended job to run at any sort of regular interval, you can create a `crontab` (cron table) entry for it.
8. `Crontab` files are read by the `cron` daemon, which looks every minute to see whether any jobs need to run.
9. Restrictions can be placed on who can use `cron` by creating a `cron.allow` or a `cron.deny` file.
10. There are six fields to each entry in the `cron` tables: the minute the job is to run (0 to 59), the hour the job is to run (0 to 23), the day of the month (1 to 31), the month of the year (1 to 12), the day of the week (0 to 6), and the path to the executable that is to run.

Essential System Services

Table 2-9 shows the subtopics, weights, descriptions, and key knowledge areas for this topic.

Table 2-9 Breakout of Domain 108

| <i>Subtopic</i> | <i>Weight</i> | <i>Description</i> | <i>Key Areas</i> |
|----------------------------------|---------------|---|--|
| Maintain system time | 3 | Properly maintain the system time and synchronize the clock | NTP |
| System logging | 2 | Configure the syslog daemon | Configure the logging daemon to send log output to a server |
| Mail Transfer Agent (MTA) basics | 3 | Commonly available MTA programs | Be able to perform basic forward and alias configuration on a host |
| Manage printers and printing | 2 | Manage print queues and user print jobs | Use both CUPS and LPD |

To adequately address these topics, focus on the following files, terms, and utilities: `/etc/cups`, `/etc/localtime`, `/etc/ntp.conf`, `/etc/timezone`, `/usr/share/zoneinfo`, `~/forward`, CUPS config files/tools/utils, `date`, `exim`, `hwclock`, `klogd`, `logger`, `lpd` legacy interface (`lpr`, `lprm`, `lpq`), `mail`, `mailq`, `newaliases`, `ntpd`, `ntpdate`, `pool.ntp.org`, `postfix`, `qmail`, `sendmail`, `syslog.conf`, `syslogd`.

Here are the top ten items to know as you study for this domain:

1. The Network Time Protocol daemon (`ntpd`) maintains the time on all servers using NTP.
2. The `hwclock` command can be used to display the date and time of a system's hardware clock (also known as the *real-time clock*).
3. The time zone is configured in the `/etc/timezone` file. Local time is likewise configured in `/etc/localtime`.
4. The `sendmail` service is a general purpose SMTP program used for sending e-mail between servers.
5. The `mailq` command shows a list of messages in the mail queue and works `sendmail`.
6. The `newaliases` command builds a database for the mail aliases file.
7. Mail can be forwarded from one e-mail address to another using a `.forward` file.

8. Line printers are rarely used anymore, but support for them remains. The primary utilities associated with them were/are as follows: `lpr` (to submit a print job), `lpq` (to see the print queue), and `lprm` (to remove queued print jobs).
9. The Common Unix Printing System (CUPS) is the most common printing interface used on Linux today. It provides support for the line-printer daemon as well as for Server Message Block (SMB).
10. The kernel logging daemon (`klogd`) logs Linux kernel messages.

Networking Fundamentals

Table 2-10 shows the subtopics, weights, descriptions, and key knowledge areas for this topic.

| <i>Subtopic</i> | <i>Weight</i> | <i>Description</i> | <i>Key Areas</i> |
|------------------------------------|---------------|---|--|
| Fundamentals of Internet protocols | 4 | Demonstrate a proper understanding of TCP/IP | Know networking fundamentals |
| Basic network configuration | 4 | Be able to view, change, and verify configuration settings on clients and hosts | Manually and automatically configure network interfaces |
| Basic network troubleshooting | 4 | Be able to troubleshoot networking issues on clients and hosts | Debug problems associated with the network configuration |
| Configure client side DNS | 2 | Be able to configure DNS on a client/host | Modify the order in which name resolution is done |

To adequately address these topics, focus on the following files, terms, and utilities: `/etc/hostname`, `/etc/hosts`, `/etc/nsswitch.conf`, `/etc/resolv.conf`, `/etc/services`, `dig`, `ftp`, `host`, `hostname`, `ifconfig`, `ifdown`, `ifup`, `netstat`, `ping`, `route`, `telnet`, `tracpath`, and `traceroute`.

Here are the top ten items to know as you study for this domain:

1. IPv4 uses 32-bit addresses divided into four octets. The first octet identifies the class of address (A, B, C). The address can be public or private.

2. The `ifconfig` utility can be used to see the current IP configuration of the network cards.
3. The `ping` utility is an all purpose tool for testing connectivity. It will send echo messages to a specified host to see if it can be reached. It can be used with the loopback address (127.0.0.1) to test internal configuration.
4. Instead of using `ping`, one can use `traceroute` to see the route taken to reach a particular host.
5. The `route` utility will display the routing table and allow you to configure it.
6. The `netstat` utility will show the current status of ports — those that open, those that are listening, and so on.
7. The name of the network host is configured in `/etc/hostname` and can be viewed with the `hostname` command.
8. You can remotely log in to another host with `telnet`, but it's highly recommended that this utility no longer be used due to very weak security.
9. FTP servers can be used to transfer files from one host to another.
10. DNS is used for resolving names to addresses. Utilities that can be used in conjunction with it include `dig` (for DNS lookup).

Security

Table 2-11 shows the subtopics, weights, descriptions, and key knowledge areas for this topic.

| Table 2-11 | | Breakout of Domain 110 | |
|---------------------------------------|---------------|---|------------------------------------|
| <i>Subtopic</i> | <i>Weight</i> | <i>Description</i> | <i>Key Areas</i> |
| Perform security administration tasks | 3 | Review system configuration to ensure host security | Understand local security policies |
| Setup host security | 3 | Know how to setup a basic level of host security | Understand TCP wrappers |
| Securing data with encryption | 3 | Key techniques that secure data | OpenSSH and GnuPG |

To adequately address these topics, focus on the following files, terms, and utilities: `/etc/hosts.allow`, `/etc/hosts.deny`, `/etc/inetd.conf`, `/etc/inetd.d/*`, `/etc/init.d/*`, `/etc/inittab`, `/etc/nologin`, `/etc/passwd`, `/etc/shadow`, `/etc/ssh/ssh_host_dsa_key`, `/etc/`

ssh/ssh_host_rsa_key, /etc/ssh_known_hosts, /etc/sudoers, /etc/xinetd.conf, /etc/xinetd.d/*, ~/.gnupg/*, ~/.ssh/authorized_keys, ~/.ssh/id_dsa, ~/.ssh/id_rsa, chage, find, gpg, id_dsa.pub, id_rsa.pub, lsof, netstat, nmap, passwd, ssh, ssh_host_dsa_key.pub, ssh_host_rsa_key.pub, ssh-add, ssh-agent, ssh-keygen, su, sudo, ulimit, and usermod.

Here are the top ten items to know as you study for this domain:

1. Adding 1000 to standard permissions turns on the “sticky bit”, whereas 2000 turns on the SGID permission and 4000 turns on the SUID permission.
2. Links are created with the `ln` command. A *hard link* is nothing more than an alias to a file (sharing the same inode). A symbolic link is created with `ln -s` and is an actual file with its own inode. The symbolic link contains a pointer to the original file and can span across file systems (while the hard link cannot).
3. Passwords are changed with the `passwd` command. While older systems stored passwords in `/etc/passwd`, they are now in `/etc/shadow` where they are more secure.
4. To see who logged on most recently and may currently still be logged on, you can use the `last` command.
5. The `su` command allows you to become another user (returning with `exit`). If no other username is specified, then the `root` user is implied, hence `su` for *superuser*.
6. To run a command as another user (usually `root`) rather than become them, `sudo` should be used instead of `su`.
7. The `who` command shows who is logged on; the `w` command shows information combining `who` with `uptime`.
8. You can limit which hosts can remotely connect by using either a `hosts.allow` file (only those hosts specifically listed can connect) or a `hosts.deny` file (only those hosts specifically listed cannot connect).
9. The `ulimit` utility can show the limit on the number of open files allowed in Linux. You can also change that value by using this same command.
10. The `usermod` command changes attributes for a user and modifies the user account.

Chapter 3: Other Linux Certifications

In This Chapter

- ✓ Overview of vendor-neutral certifications
- ✓ Overview of vendor-specific certifications

Previous chapters look at the Linux Essentials exam – LPI’s lower-level certification – and then at the the higher entry-level CompTIA Linux+ certification (consisting of the LPI LX0-101 and LX0-102 exams). As important as those exams are, they are far from the only Linux certifications available.

In the following sections, we will look first at other vendor-neutral certifications, and then an overview of some of the more popular vendor-specific Linux certification.

Vendor-Neutral Certifications

Just as the CompTIA Linux+ Powered by LPI certification is a great entry-level authentication of basic knowledge, so too are most other certifications from CompTIA. The only operating system-specific one they have is Linux+, but they also offer such other certifications as A+ (hardware), Network+ (computer networking), Security+ (host and client security), and Green IT (sustainability). All are well recognized and represented in the market and good choices for adding to a resume.

LPI also offers a number of certifications above the LPIC-1 level. LPIC-2, which requires passing another two exams (referenced as 201 and 202), focuses on such advanced topics as network configuration, file storage, troubleshooting, and system security. LPIC-3 is for senior-level administrators and requires you to take one exam of your choice — on top of having attained the LPIC-2 certification. The exam you choose to take is the one that hones in on a specific area of expertise, such as virtualization and high availability or security.

Some other vendor-neutral Linux certifications once existed and were popular, but most of those have now fallen by the wayside – either no longer offered or no longer kept current. Although those certifications may hold value for those who currently hold them, they should be avoided by those who are currently looking to have a third-party authenticate their knowledge/skills.

Vendor-Specific Certifications

A number of vendors offer certifications that authenticate specialization in their specific distributions of Linux. The three most popular are discussed in this section.

One of the most recognized is those from Red Hat. At the entry level, the company offers the Red Hat Certified System Administrator (RHCSA) certification. The more recognized Red Hat Certified Engineer (RHCE) builds upon RHCSA, and the pinnacle certification is Red Hat Certified Architect (RHCA).

Novell/SUSE certification is available at four levels: SUSE Certified Linux Administrator (CLA), SUSE Certified Linux Desktop Administrator, SUSE Certified Linux Professional (CLP), and SUSE Certified Linux Engineer (CLE). Most of these certifications build on each other — CLA leads to CLP with another exam, and then you move on to CLE, and so on.

Oracle — now having acquired Sun Microsystems — offers both Oracle Certified Associate (OCA) and Oracle Certified Professional (OCP), and Certified Specialist (CS) certifications.

Index

Symbols and Numerics

- command, 144
 - ; command, 144
 - : command, 452
 - :! command, 149
 - ! command, 238
 - ? command, 238
 - . command, 144, 452
 - ' command, 144
 - { command, 452
 - % command, 144
 - ^ command, 144
 - + command, 144
 - = command, 144
 - \$ command, 144
 - / directory, 111
 - \$< variable, 475
 - \$? variable, 475
 - \$* variable, 475
 - \$\$ variable, 475
 - \$\$^ variable, 475
 - \$\$+ variable, 475
 - * (asterisks), 95–96, 305, 494
 - @ (at sign), 116
 - \ (backslash), 91, 272
 - : (colon), 91, 142, 272, 343, 399
 - { } (curly braces), 249, 264, 448–449
 - \$ (dollar sign), 289, 474
 - .. (dot-dot), 115, 494
 - = (equal sign), 348
 - ! (exclamation point), 97, 273
 - / (forward slash), 109, 111
 - > (greater-than sign), 93–94
 - # (hash mark), 249, 380, 449
 - (hyphen), 117, 470
 - < (less-than sign), 93–94
 - . (period), 111, 119–120, 144, 494
 - | (pipe), 92, 105, 496
 - # (pound sign), 189, 208, 264, 271, 438
 - ? (question marks), 95–96, 208, 494
 - ;(semicolon), 380, 451, 496
 - /(slash), 116, 143, 147, 352–353
 - [] (square brackets), 95–96
 - ~ (tilde) character, 115, 146
 - oo option, 471
 - 10Base2, 173
 - 10Base5, 173
 - 10BaseT, 173
 - 24-bit IV, 182
 - 32-bit cyclic redundancy code (CRC-32), 182
 - 127.0.0.1, reverse mapping, 295
 - 802.11a standard, 180
 - 802.11b standard, 179–180
 - 802.11g standard, 180
-
- ## A
-
- a command, 145, 148
 - A command, 148
 - A resource record type, 290, 292
 - AAAA resource record type, 290
 - Abacus portsentry, 441
 - accessing DOS/Windows file system, 368–371
 - acpid service, 254
 - acpi=off boot option, 44
 - action field, 311
 - Active Window icon (KDE), 85
 - ad hoc modes, 180–181
 - adding newsgroups, 276–277
 - administrative tasks, in CompTIA Linux+ Exam, 511–512
 - ADSL (Asymmetric DSL), 157
 - Advanced Packaging Tool (APT), 50
 - AirSnort, 441
 - alias command, 98, 452, 509
 - allowcddma boot option, 44
 - allownewnews parameter, 272
 - all_squash option, 375
 - alt category, 219
 - anongid=GID option, 376
 - anonuid=UID option, 376
 - ansi option, 470
 - apache service, 254, 438
 - Apache Web Server vulnerability, 433
 - apic boot option, 44
 - apmd service, 254
 - append command, 238
 - applets, 121
 - application gateway, 392
 - Application layer, of TCP/IP, 168
 - Application Starter, 82–85
 - application-proxy gateway firewall, 420
 - applications
 - about, 19–21, 127–128
 - calculators, 132–133
 - calendars, 132
 - graphics and imaging about, 136
 - GIMP, 18, 20, 136–137
 - GNOME Ghostview, 18, 138
 - multimedia
 - about, 133
 - burning CDs/DVDs, 135–136
 - digital camera, 133–134
 - playing audio CDs, 134–135
 - playing sound files, 135
 - office, 128–132

Applications category (KickOff), 83
 Applixware, 20
 apropos command, 98
 APT (Advanced Packaging Tool), 50
 apt-get command, 11, 50, 128
 AR variable, 475
 ARFLAGS variable, 475
 arguments, 61, 91
 Arkeia utility, 363
 ARPANET, 169, 279
 AS variable, 290, 475
 ascii command, 238
 ASCII-armored format, 409
 ASFLAGS variable, 475
 associates, 244
 asterisks (*), 95–96, 305, 494
 Asymmetric DSL (ADSL), 157
 async option, 375
 at command, 331–333, 512
 at sign (@), 116
 atd service, 254, 331
 atq command, 512
 atrm command, 333, 512
 audio CDs, playing, 134–135
 audit, 429
 authentication
 defined, 392
 in security policy, 387
 vulnerability, 433
 authorization, in security policy, 387
 autoconf software package, 17
 autofs service, 254
 automake software package, 17
 automated backups, 367
 automatic command completion, 95
 automatically starting servers, 313–314
 awk command, 459–463

B

b command, 149
 -b option, 477
 backdoor, 392
 backing up files
 about, 361
 commercial backup utilities, 362–363
 selecting backup strategy and media, 361–362
 tar command, 363–367
 hard drive before installation, 33
 backslash (\), 91, 272
 bash shell. *See also* shell scripting
 about, 17, 90, 509
 asterisks in, 95–96
 automatic command completion, 95
 combining commands, 92
 command syntax, 90–92
 controlling command input and output, 92–94
 question marks in, 95–96
 repeating previously typed commands, 97
 starting, 60–61
 bastion host, 392
 batch files, 106
 bc software package, 17
 Berkeley Internet Name Domain (BIND)
 about, 282
 DNS vulnerability, 433
 named daemon, 254, 282–283, 296
 resolver library, 280, 283
 utility programs, 284–285
 Berkeley sockets interface, 242
 bg command, 100, 453
 /bin directory, 111, 354
 binary command, 238

BIND. *See* Berkeley Internet Name Domain (BIND)
 Binutils software package, 17
 bionet category, 219
 BIOS, reconfiguring, 36
 bison, 486
 bit bucket, 94
 bit category, 219
 biz category, 220
 black box, 440
 block devices, 326
 Bogomips, 58, 59
 Bookmarks menu (Firefox), 212
 /boot directory, 111, 354
 boot loader, 57–58
 boot messages, 58
 boot : prompt, 44
 bootable flash drive, creating, 35
 /boot/grub file, 314
 /boot/grub/menu.lst file, 314, 435
 BOOTPROTO parameter, 186, 200
 boots
 automatically starting servers, 313–314
 /etc/inittab file, 310–311
 init command, 311–312
 init process, 308–310
 manually starting/stopping servers, 313
 startup scripts, 312–313
 /boot/System.map file, 314
 /boot/vmlinuz file, 314
 bottom panel (GNOME), 73–74
 bounce keys, 511
 break command, 453, 480, 509
 BRU utility, 362
 bt command, 480
 buffer, 145

buffer overflow, 392
 built-in commands, `bash`,
 451–455
 burning CDs/DVDs,
 135–136
 business requirements, for
 security, 385–386
`bye` command, 238

C

`c` command, 145
`C` command, 148
 C++ compiler, 17, 468–472
`C` operator, 265
`-c` option, 470
`-C` option, 477
 CA (certificate
 authority), 392
 CA ARCserve Backup for
 Linux utility, 363
 cable modem
 about, 155
 connecting with
 about, 161
 how it works, 161–163
 setup, 163–166
 Cable Modem Termination
 System (CMTS),
 162–163
 cable/DSL router,
 161, 165
 cables, Ethernet, 173–175
 caching name server
 configuring, 286–296
 starting and testing,
 295–296
`cal` command, 101
 Calc (LibreOffice.org),
 130–131
 calculator apps, 132–133
 calendar apps, 132
 careers, on Linux Essentials
 Certification Exam,
 492–493

Carrier-Sense Multiple
 Access/Collision
 detection (CSMA/
 CD), 172
 case statement, 450–451
`cat` command, 92, 95, 99
 categories
 of shielded and
 unshielded twisted-pair
 cables, 173–174
 tasks by in YaST Control
 Center, 305
`cc` command, 148
`CC` variable, 475
`cd` command, 98, 115, 238,
 453, 495, 506
`cd images` command, 121
`cdrdao`, 136
`cdrecord`, 136
 CD-ROM, mounting, 357
 CDs
 audio, playing, 134–135
 burning, 135–136
 installing from, 29–31
 mounting, 25
 central processing unit
 (CPU), 9
 CERT Coordination
 Center (CERT/CC)
 (website), 397
 CERT resource record
 type, 291
 certificate, defined, 392
 certificate authority (CA), 392
 certifications
 vendor-neutral, 517
 vendor-specific, 518
`CFLAGS` variable, 475
`chage` command, 396,
 400–401
 chain, 424
 changing
 directories, 495
 file ownerships, 118–119,
 350, 402

file permissions,
 118–119, 403
 home page in Firefox,
 212–215
`CHANNEL` parameter, 186
 character devices, 327
 characters, substituting/
 deleting from files,
 105–106
 check digit, 459
 checking
 connectivity to host, 195
 disk performance/disk
 usage, 321–322
 IP routing table, 194
 network interfaces,
 193–194
 network status, 195–197
 PC hardware, 31–33
 for set user ID
 permission, 405
 Cheops, 441
`chgrp` command,
 402, 508
`chkconfig` command,
 251–252, 314, 438
`chmod` command, 98,
 118–119, 238, 499, 508
`chown` command, 98,
 402, 508
`chsh` command, 100
 Cinnamon, 69–70, 75–76
`clari` category, 220
`clear` command, 480
 client architecture, 241
 client/server model,
 sockets and, 243–244
`close` command, 238
 CMTS (Cable Modem
 Termination System),
 162–163
`CNAME` resource record
 type, 291
`CO` variable, 475
 coaxial cable, 162

- CodeWeavers CrossOver Office, 21
- COFLAGS variable, 475
- Collier-Brown, David (author)
 - Using Samba*, 3rd Edition, 380
- colon (:), 91, 142, 272, 343, 399
- colon command mode, 146
- combining shell
 - commands, 92
- !command, 144
- command command, 453
- COMMAND heading, 319
- command history, 97
- command input/output, controlling, 92–94
- command interpreter, 60
- command line, 61, 91, 493–496, 495–496
- command mode, 142
- COMMAND.COM, 90
- command-line
 - FTP client, 236–240
 - options, 91
- commands
 - command, 144
 - ; command, 144
 - : command, 452
 - :! command, 149
 - ! command, 238
 - ? command, 238
 - . command, 144, 452
 - ` command, 144
 - { command, 452
 - % command, 144
 - ^ command, 144
 - + command, 144
 - = command, 144
 - \$ command, 144
 - a, 145, 148
 - A, 148
 - at, 331–333, 512
 - alias, 98, 452, 509
 - append, 238
 - apropos, 98
 - apt-get, 11, 50, 128
 - ascii, 238
 - atq, 512
 - atrm, 333, 512
 - awk, 459–463
 - b, 149
 - bash built-in, 451–455
 - bg, 100, 453
 - binary, 238
 - break, 453, 480, 509
 - bt, 480
 - bye, 238
 - c, 145
 - C, 148
 - cal, 101
 - cat, 92, 95, 99
 - cc, 148
 - cd, 98, 115, 238, 453, 495, 506
 - cd images, 121
 - chage, 396, 400–401
 - chgrp, 402, 508
 - chkconfig, 251–252, 314, 438
 - chmod, 98, 118–119, 238, 499, 508
 - chown, 98, 402, 508
 - chsh, 100
 - clear, 480
 - close, 238
 - !command, 144
 - command command, 453
 - compress, 100
 - continue, 453, 480
 - cp, 98, 119–120, 369–370, 506
 - cpio, 17, 100
 - crontab, 333–336, 367, 512
 - Ctrl+D, 149
 - Ctrl+L, 149
 - Ctrl+U, 149
 - cut, 99, 496, 507
 - d, 143, 145
 - D, 148, 268
 - date, 101, 103–104
 - dd, 44, 99, 148
 - declare, 453
 - delete, 239
 - depmod, 328
 - df, 101, 123–125, 508
 - dG, 148
 - diff, 17, 99
 - dir, 239
 - for directory navigation, 114–115
 - dirs, 453
 - disconnect, 239
 - display, 480
 - dselect, 505
 - du, 101, 123–125, 365, 508
 - dw, 148
 - echo, 453
 - enable, 453
 - env, 348, 509
 - eval, 453
 - exec, 453
 - exit, 453
 - expand, 99
 - export, 453, 509
 - expr, 450
 - failsafe Knoppix boot command, 40
 - fb1280x1024 Knoppix boot command, 40
 - fc, 453
 - fdformat, 101
 - fdisk, 101
 - fg, 100, 453
 - file, 99, 480
 - find, 99, 121–122, 396, 496, 507
 - fold, 99
 - free, 100
 - fsck, 101, 508
 - gcc, 18, 468–469, 469–470

- get, 239
- gpg, 390, 408–412
- grep, 18, 51, 62, 91, 92, 96, 99
- groups, 100
- gunzip, 100
- gzip, 18, 100, 496
- h, 149
- halt, 100
- hash, 239, 454
- help, 239, 452, 454, 480
- history, 97, 454
- hwclock, 513
- i, 143, 145, 148
- I, 148
- id, 101, 311
- ifconfig, 193, 498, 515
- image, 239
- info, 98, 495
- info break, 480
- info files, 480
- info func, 480
- info local, 480
- info prog, 480
- info var, 480
- init, 102, 311–312, 503
- insmod, 328
- iptables, 164, 421–422, 424–426
- j, 149
- J, 148
- jobs, 454
- join, 496, 507
- k, 149
- kill, 100, 454, 481
- knoppix 1, 41
- knoppix 2, 41
- knoppix acpi=off, 41
- knoppix atapicd, 41
- knoppix
 - desktop=wmname, 41
- knoppix dma, 41
- knoppix
 - floppyconfig, 41
- knoppix fromhd=/dev/hdal, 41
- knoppix hsync=80, 41
- knoppix lang=xx, 41
- knoppix mem=256M, 41
- knoppix myconf=/dev/hdal, 41
- knoppix myconf=scan, 41
- knoppix noeject, 42
- knoppix noprompt, 42
- knoppix nowheel, 42
- knoppix noxxx, 42
- knoppix pci=bios, 42
- knoppix pnpbios=off, 42
- knoppix screen=resolution, 42
- knoppix testcd, 42
- knoppix tohd=/dev/hdal, 42
- knoppix toram, 42
- knoppix vga=ext, 42
- knoppix vsync=60, 42
- knoppix
 - wheelmouse, 42
- knoppix
 - xmodule=modname, 43
- knoppix xserver=progname, 43
- ksyms, 328
- l, 149
- last, 499, 516
- lcd, 239
- ldconfig, 504
- ldd, 100, 504
- less, 19, 99
- Linux
 - about, 62–63, 98–101
 - date, 103–104
 - managing processes, 102–103
 - processing files, 104–106
 - time, 103–104
- list, 481
- ln, 98, 499, 516
- local, 454
- locate, 99, 122
- logger, 498, 503
- logout, 454
- logrotate, 498, 503
- lpq, 514
- lpr, 99, 514
- lprm, 514
- ls, 98, 116–118, 119, 239, 350, 402, 495, 507
- lsmod, 328, 329, 503
- mail, 258
- mailq, 513
- make, 19, 476–478, 481
- make config, 503
- man, 98, 495
- managing user accounts
 - with, 342–343
- mdelete, 239
- mdir, 239
- mget, 239
- mkdir, 98, 120–121, 239
- mkfs, 101
- mknod, 101
- mkswap, 101
- mls, 239
- modinfo, 328, 503
- modprobe, 328, 329, 330, 503
- more, 63, 99
- mount, 101, 356, 357, 358, 368–369, 508
- mput, 239
- mv, 98, 495, 506
- n, 144
- n, 145
- ^n, 145
- +n, 144
- netstat, 195, 397, 498, 515
- newaliases, 513
- newgrp, 499, 512
- next, 481
- nice, 100
- nl, 99
- open, 240
- p, 149
- P, 149, 265
- pack, 496

commands (continued)

- passwd, 101, 397, 516
- paste, 99, 496, 507
- patch, 19, 99
- ping, 195, 441, 498, 515
- popd, 454
- print, 481
- printenv, 100, 347
- prompt, 240
- ps, 63, 100, 496, 506
- pstree, 100
- pushd, 454
- put, 240
- pwd, 98, 115, 240, 454, 506
- q, 144, 145
- :q, 149
- Q, 145
- :q!, 149
- quit, 240, 481
- quota, 508
- r file, 145
- :r filename, 149
- read, 454, 509
- readonly, 454
- reboot, 100
- recv, 240
- rename, 240
- repeating previously typed, 97
- return, 454
- rm, 98, 120, 495, 506
- rmdir, 98, 240, 506
- rmmmod, 328, 503
- run, 481
- runlevel, 310, 311
- rx, 148
- /sbin/ifconfig, 193
- /sbin/route, 194
- sed, 19, 99, 457–463, 507
- send, 240
- server, 250–251
- set, 454, 509
- set variable, 481
- shell, 61–62, 92
- shell, 481
- shift, 454
- shutdown, 100, 503
- size, 240
- s/old/new/, 145
- sort, 99, 105
- split, 99, 106
- status, 240
- step, 481
- /string, 149
- ?string, 149
- su, 101, 102, 306, 397, 499, 516
- swapoff, 101
- swapon, 101
- sync, 101, 375
- tac, 99
- tail, 99
- tar, 19, 100, 363–367, 496
- tcpdump, 197, 441
- telinit, 312
- test, 449–450, 509
- testparm, 378, 379
- /text/, 144
- ?text?, 144
- time, 19, 103–104
- times, 454
- top, 100, 496, 506
- touch, 98
- tr, 99, 105–106, 507
- trap, 454
- tty, 101
- type, 455
- u, 145, 149
- U, 149
- ulimit, 397, 455, 516
- umask, 403–405, 455
- umount, 101, 356–357
- unalias, 98, 455
- uname, 62, 100
- uncompress, 100
- uniq, 99
- unset, 455, 509
- update-rc.d, 252–253, 314
- uptime, 319–320, 516
- user, 240
- useradd, 499, 512
- userdel, 499
- w, 149, 499
- w file, 145
- W file, 145
- :w filename, 149
- wait, 455
- watch, 481
- wc, 100, 104–105, 496, 507
- whatis, 98, 495
- where, 481
- whereis, 99
- which, 99
- who, 499, 516
- :wq, 149
- x, 148, 481
- xargs, 496
- yy, 149
- zcat, 100
- zless, 100
- zmore, 100
- commercial backup utilities, 362–363
- Common Unix Printing System (CUPS), 514
- Common Vulnerabilities and Exposures (CVE) (website), 432
- community, on Linux Essentials Certification Exam, 492–493
- comp category, 220
- compress command, 100
- CompTIA Linux+ exams
 - about, 501–502
 - administrative tasks, 511–512
 - devices, Linux file systems, file system hierarchy standard, 507–508
 - essential system services, 512–514
 - GNU and Unix commands, 505–507

- Linux installation and
 - package management, 503–505
 - networking, 514–515
 - security, 515–516
 - shells, scripting, and data management, 509–510
 - system architecture, 502–503
 - user interfaces and desktops, 510–511
 - Computer category (KickOff), 83
 - computer program, 465
 - computer security, 391–397
 - computer security audit
 - about, 429–430
 - defined, 429
 - implementing
 - methodology for about, 431–432
 - common vulnerabilities, 432–434
 - host-security review, 434–437
 - network security review, 438–439
 - nontechnical aspects of, 430
 - security testing tools, 440–442
 - technical aspects of, 431
 - vulnerability testing types, 440
 - concatenate, 118
 - conditional
 - expressions, 463
 - confidentiality, 392
 - configuration files, 314–317
 - configuration lists, 276
 - configuring. *See also* installing; troubleshooting
 - caching name server, 286–296
 - INN server, 269–275
 - Internet super server, 414
 - KDE bottom panel, 85–86
 - KDE desktop, 86–88
 - networks at boot time, 199–201
 - primary name server, 296–298
 - resolver, 285–286
 - Samba, 379–380
 - TCP wrapper security, 414–415
 - wireless access point, 184
 - wireless networking, 185–188
 - connecting LAN to Internet, 177–178
 - connectionless protocols, 243
 - connection-oriented protocols, 242–243
 - console, 89
 - context menus (KDE)
 - desktop, 80–81
 - icons, 81–82
 - continue command, 453, 480
 - controls statement, 288
 - copying files, 495
 - Coreutils software package, 17
 - counting words/lines in text files, 104–105
 - cp command, 98, 119–120, 369–370, 506
 - cpio command, 17, 100
 - CPP variable, 475
 - CPPFLAGS variable, 475
 - CPU (central processing unit), 9
 - cpu field name, 321
 - %CPU heading, 319
 - cracker, 392
 - creating
 - bootable flash drive, 35
 - key pair, 408–409
 - working configuration file, 39
 - cron daemon, 254, 333–336
 - crontab command, 333–336, 367, 512
 - CrossOver Office, 21
 - CSMA/CD (Carrier-Sense Multiple Access/Collision detection), 172
 - ctlinnd, 270
 - Ctrl+D command, 149
 - Ctrl+L command, 149
 - Ctrl+U command, 149
 - CUPS (Common Unix Printing System), 514
 - curly braces ({}), 249, 264, 448–449
 - current directory, 114–115
 - cut command, 99, 496, 507
 - CVE (Common Vulnerabilities and Exposures) (website), 432
 - CVS (Subversion, Concurrent Versions System), 23, 433
 - CXX variable, 475
 - CXXFLAGS variable, 475
 - CyberCop Scanner, 441
-
- ## D
-
- d command, 143, 145
 - D command, 148, 268
 - d option, 477
 - daemon, 270
 - data management, in CompTIA Linux+ Exam, 509–510
 - data protection, in security policy, 387
 - databases, vulnerability of, 434
 - datagrams, 243
 - date, working with, 103–104
 - date command, 101, 103–104
 - dd command, 44, 99, 148

- DDoS (Distributed Denial of Service), 383, 393
- Debian
 - about, 11
 - BIND, 282
 - configuring networks, 199
 - distributions, 38
 - init process, 310
 - installing
 - INN server, 268
 - Samba, 379
 - software in, 50–52
 - software-development tools, 467
 - mounting CD-ROM, 357
 - runlevel command, 310
 - starting
 - innd, 275
 - NFS server, 359, 376
 - Samba, 380
 - standalone servers in, 251
 - stopping standalone servers in, 251
 - turning off standalone servers, 413
 - update-rc.d command, 252–253, 314
 - updates, 398
- debug parameter, 330
- declare command, 453
- decrypting
 - defined, 392
 - documents, 411–412
- delay loop, 59
- delete command, 239
- deleting characters from files, 105–106
- Denial of Service (DoS), 383, 386, 393
- depmod command, 328
- derived work, 485
- DES, 345
- desktop, GNOME, 70–71
- desktop context menus (KDE), 80–81
- Desktop Pager icon (KDE), 85
- detection concept, in
 - security programs, 389, 432, 434, 438
- /dev directory, 111, 326, 354
- device drivers, 325
- device files, 325, 326–327
- DEVICE parameter, 186
- devices
 - in CompTIA Linux+ Exam, 507–508
 - Linux
 - about, 325–326
 - device files, 326–327
 - persistent device naming with udev, 327–328
 - mounting on file system, 355–357
 - peripheral, 25–26
 - /dev/null file, 94
- df command, 101, 123–125, 508
- dG command, 148
- DHCP (Dynamic Host Configuration Protocol), 170, 245
- dial-up, compared with DSL and cable, 155
- diff command, 17, 99
- dig utility program, 284–285
- digiKam app, 133–134
- digital camera apps, 133–134
- digital signatures, 393, 407–408
- Digital Subscriber Line. *See* DSL (Digital Subscriber Line)
- dir command, 239
- directories
 - about, 351–352
 - changing, 495
 - commands for listings and permissions, 116–118
 - commands for working with, 120–121
- defined, 109
- navigating with
 - commands, 114–115
- in /proc, 324–325
- protecting
 - about, 402
 - changing file
 - ownerships, 402
 - changing file permissions, 403
 - checking for set user ID permission, 405
 - setting default permission, 403–405
 - viewing ownerships and permissions, 402
- standard in Linux file system, 354
- top-level, 111–112
- directory path, 208
- dirs command, 453
- disclosure of information to public, 386
- disconnect
 - command, 239
- disk partition, 29
- disk-space usage,
 - commands for, 123–125
- display command, 480
- DISPLAY environment variable, 349
- display=IP_address:0
 - boot option, 44
- Distributed Database, 279
- Distributed Denial of Service (DDoS), 383, 393
- distributed
 - responsibility, 280
- distribution list, 273
- distribution media, 25
- Distribution Specific icon, 4
- distributions
 - about, 16
 - contents of, 16–24
 - GNU software, 16–19

- GUIs and applications, 19–21
 - Internet servers, 21–22
 - Linux, 10–14
 - networks, 21
 - online documentation, 22–23
 - software development, 22
 - distribution-specific
 - version numbers, 15
 - DistroWatch (website), 11
 - DIX standard, 173
 - DMACRO option, 470
 - DMACRO=DEFN option, 471
 - DMZ, 393
 - DNAME resource record
 - type, 291
 - dn1 (delete through newline) macro, 260–261
 - DNS. *See* Domain Name System (DNS)
 - DOCSIS, 163
 - documents, decrypting and
 - encrypting, 411–412
 - dollar sign (\$), 289, 474
 - domain name, 208
 - domain name system (DNS)
 - about, 171, 279–280
 - Berkeley Internet Name Domain (BIND)
 - about, 282
 - named daemon, 282–283
 - resolver library, 283
 - utility programs, 284–285
 - configuring
 - caching name server, 286–296
 - primary name server, 296–298
 - resolver, 285–286
 - hierarchical domain names, 281–282
 - domain parameter, 272
 - domains, on Linux+ Exams, 502
 - DoS (Denial of Service), 383, 386, 393
 - DOS file system, accessing, 368–371
 - DOS floppy disks, mounting, 369–370
 - DOS/Windows disk
 - partition, mounting, 368–369
 - dot-dot (..), 115, 494
 - dotted-decimal
 - notation, 169
 - dotted-quad notation, 169
 - downstream data, 161
 - driverdisk boot
 - option, 44
 - dselect command, 505
 - DSL (Digital Subscriber Line)
 - about, 154
 - connecting with
 - about, 156
 - ADSL, IDSL, SDSL, 157–158
 - how it works, 156–157
 - modem, 156
 - setup, 158–161
 - DSL/cable modem NAT
 - router, 177
 - dsniff, 441
 - du command, 101, 123–125, 365, 508
 - dual-homed host, 393
 - Dummies (website), 5
 - dumps, 197
 - DVD drive, checking for
 - installation, 31
 - DVDs
 - burning, 135–136
 - installing from, 29–31
 - mounting, 25
 - dw command, 148
 - Dynamic Host Configuration Protocol (DHCP), 170
 - dynamically linked, shared libraries, 23
-
- ## E
-
- e option, 477
 - E option, 471
 - echo command, 453
 - Eckstein, Robert (author)
 - Using Samba*, 3rd Edition, 380
 - ed, 18, 141–145
 - Edit menu (Firefox), 212
 - 802.11a standard, 180
 - 802.11b standard, 179–180
 - 802.11g standard, 180
 - electronic mail (e-mail), 21–22
 - emacs software package, 18, 467
 - e-mail, 153
 - enable command, 453
 - enabling packet filtering, 421–426
 - encrypting
 - defined, 393
 - documents, 411–412
 - files with GnuPG, 406–412
 - enforcing=0 boot
 - option, 44
 - Enter, 145
 - env command, 348, 509
 - environment variable, 348
 - Epiphany, 209
 - equal sign (=), 348
 - error messages, saving in
 - files, 94
 - Esc, 149
 - essential system services,
 - in CompTIA Linux+ Exam, 512–514
 - ESSID parameter, 186
 - establishing security
 - policies, 387–388
 - /etc directory, 111, 354
 - /etc/apache2/httpd.conf file, 315
 - /etc/apt/sources.list file, 315

- /etc/at.allow file, 315
- /etc/bashrc file, 315
- /etc/cron.allow file, 435
- /etc/cron.deny file, 435
- /etc/crontab file, 435
- /etc/cups/cupsd.conf file, 315
- /etc/exports file, 375–376
- /etc/fonts file, 315
- /etc/fstab file, 315, 357–358
- /etc/group file, 315
- /etc/grub.conf file, 315
- /etc/host.conf file, 190, 191
- /etc/hosts file, 189–190, 315
- /etc/hosts.allow file, 190, 192, 315, 435
- /etc/hosts.deny file, 190, 192–193, 315, 435
- /etc/httpd/conf/httpd.conf file, 315
- /etc/init.d file, 315
- /etc/init.d/rcs file, 316
- /etc/inittab file, 310–311, 315
- /etc/issue file, 316
- /etc/lilo.conf file, 316
- /etc/login.defs file, 316
- /etc/logrotate.conf file, 435
- /etc/mail directory, 267
- /etc/modprobe.conf file, 95, 316, 329–330
- /etc/modules.conf file, 316
- /etc/mtab file, 316
- /etc/named.conf file, 287–289
- /etc/networks file, 190
- /etc/nologin file, 427
- /etc/nsswitch.conf file, 190, 193
- /etc/pam.d file, 435
- /etc/passwd file, 316, 343–344, 399–400, 435
- /etc/profile file, 316, 509
- /etc/profile.d file, 316
- /etc.rc.d file, 436
- /etc/resolv.conf file, 190, 191
- /etc/samba/smb.conf, 377, 379
- /etc/samba/smbusers, 377
- /etc/securetty file, 436
- /etc/security file, 436
- /etc/shadow file, 316, 400–401, 427, 436
- /etc/shells file, 316
- /etc/shutdown.allow file, 436
- /etc/skel file, 316
- /etc/ssh file, 436
- /etc/ssh/ssh_config, 416
- /etc/ssh/sshd_config, 416
- /etc/sysconfig file, 316, 436
- /etc/sysctl.conf file, 316, 436
- /etc/syslog.conf file, 436
- /etc/termcap file, 316
- /etc/udev file, 317
- /etc/udev/udev.conf file, 436
- /etc/vsftpd file, 436
- /etc/vsftpd.ftpusers file, 436
- /etc/X11 file, 317
- /etc/X11/xorg.conf file, 317
- /etc/xinetd.conf file, 317, 436
- /etc/xinetd.d file, 436
- /etc/yum.conf file, 317
- Ethereal, 441
- Ethernet
 - about, 157, 172
 - cables, 173–175
 - how it works, 172–173
- Ethernet hub, 174
- Ethernet LAN, setting up, 172–175
 - about, 172
 - cables, 173–175
 - how it works, 172–173
- /etc/hosts.allow file, 427
- /etc/hosts.deny file, 427
- /etc/inetd.conf file, 427
- /etc/init.d/* file, 427
- /etc/inittab file, 427
- /etc/passwd file, 427
- /etc/xinetd/conf file, 427
- /etc/xinetd.d/* file, 427
- eval command, 453
- Excel (Microsoft), 130–131
- exchanging keys, 409–410
- exclamation point (!), 97, 273
- exec command, 453
- exit command, 453
- expand command, 99
- expert boot option, 40, 45
- expire, 270
- exploit tools, 393
- export command, 453, 509
- exporting file systems with NFS, 360, 374–376
- expr command, 450
- expressions, 466

F

- F operator, 265
- f option, 477
- failsafe Knoppix boot command, 40

- fallow-single-precision option, 471
- FAT (file allocation table), 36
- Favorites category (KickOff), 83
- fb1280x1024 Knoppix boot command, 40
- fc command, 453
- FC variable, 475
- fdformat command, 101
- fdisk command, 101
- fdiv (floating point division), 324
- FEATURE macro, 263
- Fedora
 - about, 12
 - BIND, 282
 - chkconfig command, 251–252, 314
 - configuring networks, 199
 - Samba, 379
 - distributions, 38
 - /etc/fstab file, 358
 - init process, 310
 - installing Samba, 379
 - software in, 52–54
 - software-development tools, 467
 - reading RSS feeds, 230
 - security level configuration tool, 422
 - starting innd, 275
 - NFS server, 359, 376
 - Samba, 380
 - turning off standalone servers, 414
 - updates, 398
- Fedora Core (website), 12
- FFLAGS variable, 475
- fg command, 100, 453
- FHS (Filesystem Hierarchy Standard), 353
- file allocation table (FAT), 36
- file command, 99, 480
- File menu (Firefox), 212
- file sharing
 - about, 26
 - with NFS
 - about, 358–359, 373–374
 - exporting file systems, 360, 374–376
 - mounting NFS file systems, 360–361, 376–377
- file systems
 - about, 26, 109–114
 - for checking disk-space usage, 123–125
 - managing
 - about, 351–352, 361
 - accessing DOS or Windows file system, 368–371
 - backing up, 361–367
 - /etc/fstab file, 357–358
 - hierarchy, 352–355
 - mounting devices, 355–357
 - sharing with NFS, 358–361
 - for mounting and unmounting, 122–123
 - navigating with Linux
 - commands about, 114
 - for changing permissions and ownerships, 118–119
 - for directory listings and permissions, 116–118
 - for directory navigation, 114–115
 - for finding files, 121–122
 - for working with directories, 120–121
 - for working with files, 119–120
- File Transfer Protocol (FTP)
 - about, 170, 231
 - command-line client, 236–240
 - graphical clients
 - about, 231–232
 - FileZilla, 234–236
 - gFTP, 231, 232–233
 - port numbers and, 245
 - file transfer utilities, 21–22
- filenames
 - about, 208
 - in Linux, 110
- files. *See also specific files*
 - backing up
 - about, 361
 - commercial backup utilities, 362–363
 - selecting backup strategy and media, 361–362
 - tar command, 363–367
 - batch, 106
 - changing
 - permissions, 118–119, 403
 - user/group ownership of, 350, 402
 - commands
 - for filing, 121–122
 - for working with, 119–120
 - copying, 495
 - deleting characters from, 105–106
 - encrypting with GnuPG, 406–412
 - getting command input from, 93
 - getting command output from, 93–94
 - hiding, 494
 - listings, 495
 - moving, 495
 - permissions, security and, 435–437

- files. *See also specific files (continued)*
 - in `/proc`, 324–325
 - processing, 104–106
 - protecting, 402–405
 - saving error messages in, 94
 - signing with GnuPG, 406–412
 - slitting into smaller files, 106
 - substituting characters from, 105–106
 - Filesystem Hierarchy Standard (FHS), 353
 - FileZilla, 234–236
 - find command, 99, 121–122, 396, 496, 507
 - finding bugs in `gbd`, 482–483
 - Findutils software package, 18
 - finger software package, 18
 - fingerprint, 401, 407
 - Firefox
 - changing home page, 212–215
 - user interface, 210–212
 - web surfing in, 215–216
 - Firewalk, 441
 - firewall
 - about, 384
 - defined, 27, 393
 - setting up
 - about, 418–421
 - enabling packet filtering, 421–426
 - NAT, 421
 - fixing bugs in `gbd`, 483–484
 - flash drive
 - creating bootable, 35
 - installing on a, 34–35
 - floating-point division, 324
 - flow, controlling in shell scripting, 449–451
 - flow-control statements, 466
 - FOCUS-LINUX mailing list, 398
 - fold command, 99
 - for loop, 450
 - forgotten root password, 307–308
 - FORWARD chain, 424–426
 - .forward file, 267–268
 - forward slash (`/`), 109, 111
 - `-fpcc-struct-return` option, 471
 - `-fPIC` option, 471
 - FQDN (fully qualified domain name), 281–282
 - framework, security
 - about, 384–385
 - business requirements, 385–386
 - managing, 389
 - mitigation, 388–389
 - policy, 387–388
 - risk analysis, 386–387
 - free command, 100
 - Free Software Foundation (FSF), 16
 - `-freg-struct-return` option, 471
 - `fsck` command, 101, 508
 - FSF (Free Software Foundation), 16
 - FTP. *See* File Transfer Protocol (FTP)
 - full packet awareness, 420
 - fully qualified domain name (FQDN), 281–282
 - functions
 - defined, 467
 - shell, 448–449
-
- G
-
- `-g` option, 471
 - Games subcategory (KickOff), 84
 - gawk software package, 18
 - `gcc` command, 18, 468–469, 469–470
 - `gdb` software package, 18, 478–484
 - `gdbm` software package, 18
 - GECOS, `/etc/passwd` file, 343
 - General Public License (GPL), 16
 - Gentoo Linux, 12
 - `get` command, 239
 - `gets` function, 482
 - gettext software package, 18
 - getting started, 27–28
 - `gFTP`, 231, 232–233
 - ghostscript software package, 18
 - ghostview software package, 18, 138
 - GID
 - `/etc/passwd` file, 343
 - in group definitions, 344
 - GIMP (GNU Image Manipulation Program), 18, 20, 136–137
 - The GIMP User Manual* (GUM), 137
 - globbing, 494
 - GNOME
 - about, 11, 18, 20, 69–70
 - Add or Remove Software Utility, 52–54
 - bash shell, 60, 61
 - desktop, 70–71
 - logging out of, 65
 - onscreen keyboard reader, 511
 - panels, 71–74
 - text editor, 139–140
 - GNOME calculator, 132
 - GNOME Ghostview, 138
 - GNOME Strae (website), 229
 - GNU C compiler, 23, 468–472
 - GNU C++ compiler (`g++`), 23

GNU C Library software package, 18
 GNU commands, in
 CompTIA Linux+ Exam, 505–507
 GNU compiler for Java, 23
 GNU debugger (`gdb`), 23, 467, 478–484
 GNU `emacs` editor, 23
 GNU General Public License (GPL), 485–486
 GNU Library General Public License (LGPL), 485, 486–487
 GNU licenses, 14, 484–487
 GNU `make` utility, 23, 467, 472–478
 GNU Privacy Guard (GnuPG), 390, 406–412
 GNU profiling utility (`gprof`), 23
 GNU Project, 16
 GNU software, 16–19
 GNUchess software package, 18
 Gnumeric software package, 18
 GnuPG, 390, 406–412
 Google (website), 227
 Google Groups (website), 220, 227, 228
`gzip` command, 390, 408–412
 GPL (General Public License), 16
 GPL (GNU General Public License), 485–486
 GPLv3 (website), 487
`gpm` service, 254
 graphical desktop, 11
 graphical FTP clients
 about, 231–232
 FileZilla, 234–236
 gFTP, 231, 232–233
 graphical user interfaces (GUIs)
 about, 19–21, 69–70
 Cinnamon, 75–76
 GNOME
 desktop, 70–71
 panels, 71–74
 MATE, 76–77
 Unity, 74–75
 graphics and imaging applications
 about, 136
 GIMP, 18, 20, 136–137
 GNOME Ghostview, 18, 138
 Graphics subcategory (KickOff), 84
 gray box, 440
 greater-than sign (`>`), 93–94
 `grep` command, 18, 51, 62, 91, 92, 96, 99
 `grep` utility, 496, 507
 `groff` software package, 18
 `groupadd` utility, 499, 512
 `groupdel` utility, 499, 512
 `groupmod` utility, 499, 512
 Groupname, in group definitions, 344
 groups. *See also* users
 about, 337
 administration values, 345–347
 changing ownership of files, 350
 managing, 344–345
 groups command, 100
 GRUB boot loader, 57, 505
 `gtk+` software package, 18
 GUI service-configuration utility, 253–255
 gui text editors, 139–141
 GUI tools, 198, 303–305
 GUI user manager, 338–342
 GUI utilities, 307
 GUIs. *See* graphical user interfaces (GUIs)
 `gunzip` command, 100
 `gzip` command, 18, 100, 496

H

`h` command, 149
`H` operator, 265
 `-h` option, 477
`halt` command, 100
 hard disk, 24
 hard drive
 backing up, 33
 checking for installation, 31
 hard link, 516
 hardware
 checking for installation, 31–33
 defined, 9
 wireless, 183–184
`hash`, 393, 407
`hash` command, 239, 454
`hash` mark (`#`), 249, 380, 449. *See also* pound sign (`#`)
 head end, 162
`hello` function, 448–449
`help` command, 239, 452, 454, 480
 Help menu (Firefox), 212
 hexadecimal digit, 184
 hidden files, 494
`hide` option, 375
 hierarchical domain names, 281–282
 hierarchy
 directory, 111
 file system, 352–355
 HINFO resource record type, 291
`hiscachesize`
 parameter, 272
`history` command, 97, 454
 History menu (Firefox), 212
`/home` directory, 111, 354
 HOME environment variable, 349
 home page, 210, 212–215

- homedir, /etc/passwd file, 344
 - host
 - checking connectivity to, 195
 - defined, 394
 - security issues, 389, 390
 - host address, 169
 - host utility program, 284–285
 - HOSTNAME environment variable, 348, 349
 - host-security
 - about, 434–437
 - recommended tools, 441
 - hot plug, 26
 - hping2, 441
 - HTML anchor, 208
 - HTTP (HyperText Transfer Protocol), 171, 206, 245
 - httpd service, 22, 254, 438
 - HWADDR parameter, 186
 - hwclock command, 513
 - HyperText Markup Language (HTML), 206, 208
 - HyperText Transfer Protocol (HTTP), 171, 206, 245
 - hyphen (-), 117, 470
-
- I**
- i command, 143, 145, 148
 - I command, 148
 - i option, 477
 - I option, 471, 477
 - i386, 10
 - IA32 architecture
 - processors, 10
 - IBM, 10
 - IC (Integrity Check) field, 182
 - ICMP (Internet Control Message Protocol), 195
 - icon context menus (KDE), 81–82
 - icons, explained, 4
 - id command, 101, 311
 - ide=nodma boot option, 45
 - IDSL (ISDN DSL), 157
 - ieee category, 220
 - IETF (Internet Engineering Task Force), 170, 280
 - ifconfig command, 193, 498, 515
 - image command, 239
 - images
 - accessing on USB digital camera, 134
 - opening in GIMP, 137
 - IMAP (Internet Message Access Protocol), 171
 - implementing
 - security solutions, 388–389
 - security test methodology about, 431–432
 - common vulnerabilities, 432–434
 - host-security review, 434–437
 - network security review, 438–439
 - Impress (LibreOffice.org), 131–132
 - incident handling, in
 - security policy, 387
 - incident response, 437
 - incoming.conf file, 274
 - incremental backups, 366–367
 - indent software
 - package, 19
 - inetd server, 247–248, 413, 415, 438
 - info break
 - command, 480
 - info command, 98, 495
 - info files
 - command, 480
 - info func command, 480
 - info local
 - command, 480
 - info prog command, 480
 - info var command, 480
 - information sharing, 154
 - infrastructure, wireless
 - Ethernet networks, 180–181
 - init command, 102, 311–312, 503
 - init process, 308–310
 - Initialization Vector (IV), 182
 - INN server
 - configuring and starting, 269–275
 - installing, 268–269
 - website, 269
 - inn.conf file, 271–272
 - innnd service, 22, 254, 270
 - innflags parameter, 272
 - input and output
 - redirection (I/O redirection), 92–94
 - INPUT chain, 424–426
 - insecure option, 375
 - insecure_locks
 - option, 375
 - insmod command, 328
 - installing
 - about, 29, 50
 - checking PC hardware, 31–33
 - creating bootable flash drive, 35
 - on a flash drive, 34–35
 - INN server, 268–269
 - Live CD, 34
 - mail servers, 257–268
 - Samba, 378–379
 - software
 - in Debian and Ubuntu, 50–52
 - in Fedora, 52–54
 - in SUSE, 54
 - in Xandros, 55

space needed for Linux, 32–34
 steps for, 29–31
 troubleshooting
 about, 40
 Knoppix boot
 commands, 40–43
 Linux kernel boot
 options, 44–47
 PC reboot problem, 44
 signal 11 error, 43
 troubleshooting
 workstation, 36
 working with new
 drive, 36
 integrity, 394
 Integrity Check (IC)
 field, 182
 Intel 80x86 processor, 9, 10
`in.telnetd`, 22
 InterBulletin (website), 227
 Internet access, in security
 policy, 387
 Internet Assigned Numbers
 Authority
 (website), 247
 Internet connection
 about, 153–154
 cable modem
 about, 161
 how it works, 161–163
 setup, 163–166
 DSL
 about, 156
 ADSL, IDSL, SDSL,
 157–158
 how it works, 156–157
 setup, 158–161
 ways to connect, 154–155
 Internet Control Message
 Protocol (ICMP), 195
 Internet Engineering Task
 Force (IETF), 170, 280
 Internet Message Access
 Protocol (IMAP), 171
 Internet servers, 21–22

Internet services
 about, 170–171, 241–242
 Internet Super Server,
 247–250
 port numbers and,
 245–247
 securing, 413–415
 in security policy, 387
 standalone servers,
 250–255
 TCP/IP and sockets,
 242–245
 Internet subcategory
 (KickOff), 84
 Internet Super Server,
 247–250, 414
 InterNetNews
 components of, 270–274
 startup, 274–275
 internetworking, 169
 intrusion detection, 441
`io` field name, 321
 IP addresses, 169–170
 IP routing table, 194
 IP spoofing, 394
 IPSec (IP Security
 Protocol), 394
`iptables` command, 164,
 421–422, 424–426
 IPv4, 497
 IPv6, 170
`IPV6INIT` parameter, 186
`isdn` service, 254
`Isol`, 441
 ISOLINUX boot loader, 57, 58
 ISP, reading newsgroups
 from, 222–227
 ISS Internet Scanner, 441
 IV (Initialization Vector), 182

J

`j` command, 149
`J` command, 148
 -`j` option, 477

jobs, scheduling
 about, 330–331
 one-time, 331–333
 recurring, 333–336
`jobs` command, 454
 John the Ripper, 441
`join` command, 496, 507

K

`k` command, 149
 K Desktop Environment.
 See KDE (K Desktop
 Environment)
`K` operator, 265
 -`k` option, 477
`k12` category, 220
 Kbps, 154
 KDE, 11, 60, 61
 logging out of, 65
 KDE (K Desktop
 Environment), 20
 about, 79–80
 configuring
 about, 86–88
 KDE bottom panel, 85–86
 desktop context menus,
 80–81
 icon context menus, 81–82
 panel
 about, 82
 icons, 85
 Main Menu button,
 82–85
 KDE Akregator
 (website), 229
 KDE calculator, 132–133
 key pair, generating,
 408–409
 KEY resource record
 type, 291
 key ring, 409
 keyboard, checking for
 installation, 31
 keys, exchanging, 409–410

- keyword, 50–51
 - KickOff application, 83–85
 - kill command, 100, 454, 481
 - klogd daemon, 514
 - KNode, 223, 226–227
 - Knopper, Klaus (developer), 12
 - Knoppix
 - about, 12, 14
 - boot commands, 40–43
 - distributions, 38
 - root user, 306
 - update-rc.d command, 252–253
 - knoppix 1 Knoppix boot command, 41
 - knoppix 2 Knoppix boot command, 41
 - knoppix acpi=off Knoppix boot command, 41
 - knoppix atapicd Knoppix boot command, 41
 - knoppix
 - desktop=wmname Knoppix boot command, 41
 - knoppix dma Knoppix boot command, 41
 - knoppix floppyconfig Knoppix boot command, 41
 - knoppix fromhd=/dev/hdal Knoppix boot command, 41
 - knoppix hsync=80 Knoppix boot command, 41
 - knoppix lang=xx Knoppix boot command, 41
 - knoppix mem=256M Knoppix boot command, 41
 - knoppix myconf=/dev/hdal Knoppix boot command, 41
 - knoppix myconf=scan Knoppix boot command, 41
 - knoppix noeject Knoppix boot command, 42
 - knoppix noprompt Knoppix boot command, 42
 - knoppix nowheel Knoppix boot command, 42
 - knoppix noxxx Knoppix boot command, 42
 - knoppix pci=bios Knoppix boot command, 42
 - knoppix pnpbios=off Knoppix boot command, 42
 - knoppix
 - screen=resolution Knoppix boot command, 42
 - knoppix testcd Knoppix boot command, 42
 - knoppix tohd=/dev/hdal Knoppix boot command, 42
 - knoppix toram Knoppix boot command, 42
 - knoppix vga=ext Knoppix boot command, 42
 - knoppix vsync=60 Knoppix boot command, 42
 - knoppix wheelmouse Knoppix boot command, 42
 - knoppix xmodule=modname Knoppix boot command, 43
 - knoppix
 - xserver=progname Knoppix boot command, 43
 - Konqueror, 209
 - Kontakt app, 132
 - ks boot option, 45
 - ks=kickstartfile boot option, 45
 - ksyms command, 328
 - KWrite text editor, 140–141
-
- ## L
-
- l command, 149
 - l option, 471, 477
 - L option, 471
 - LAN. *See* local area network (LAN)
 - LANANA (Linux Assigned Names And Numbers Authority), 326
 - last command, 499, 516
 - LC4, 441
 - lcd command, 239
 - ldconfig command, 504
 - ldd command, 100, 504
 - LDFLAGS variable, 475
 - least privilege, 345
 - Leave category (KickOff), 83
 - less command, 19, 99
 - less-than sign (<), 93–94
 - LGPL (GNU Library General Public License), 485, 486–487
 - /lib directory, 111, 354
 - libpng software package, 19
 - LibreOffice (website), 20, 21
 - LibreOffice Suite, 128–132
 - licenses, GNU, 484–487
 - LIDSSystems, 441
 - LILO boot loader, 57
 - links, 117, 206–208
 - Linspire, 12

- Linux. *See also specific topics*
 - about, 1, 9–10
 - boots
 - automatically starting servers, 313–314
 - /etc/inittab file, 310–311
 - init command, 311–312
 - init process, 308–310
 - manually starting/stopping servers, 313
 - startup scripts, 312–313
 - commands
 - about, 62–63, 98–101
 - date, 103–104
 - managing processes, 102–103
 - navigating file system with, 114–121
 - processing files, 104–106
 - root, 101–102
 - time, 103–104
 - computer systems for, 10
 - configuration files, 314–317
 - devices
 - about, 325–326
 - device files, 326–327
 - persistent device naming with udev, 327–328
 - distributions, 10–14, 16–24
 - getting started, 27–28
 - installation and package management, in
 - CompTIA Linux+ Exam, 503–505
 - installing, 29–36
 - managing PC with, 24–27
 - space needed for, 32–34
 - starting, 57–60
 - versions, 14–15
 - web browsing in, 209–216
- Linux Assigned Names And Numbers Authority (LANANA), 326
- linux category, 220
- Linux Essentials
 - Certification Exam
 - about, 491–492
 - career, 492–493
 - command line, 493–496
 - community, 492–493
 - operating system, 496–498
 - security and file permissions, 498–499
- Linux IPv6 HOWTO, 170
- Linux kernel. *See also operating system*
 - boot options, 44–47
 - defined, 9, 57
 - versions, 14
 - vulnerability, 434
- Linux Professional Institute (LPI), 2
- Linux Standard Base (LSB), 15–16, 353
- list command, 481
- listings
 - directory, 116–118
 - files, 495
- Live CD, 34, 40
- Live version, 14
- ln command, 98, 499, 516
- loadable driver modules, managing
 - about, 328
 - /etc/modprobe.conf file, 329–330
 - loading/unloading modules, 328–329
- loadable kernel modules, 328
- loading modules, 328–329
- local area network (LAN)
 - about, 26, 167
 - configuring TCP/IP networking, 175–177
 - connecting to Internet, 177–178
- Ethernet
 - about, 172
 - cables, 173–175
 - how it works, 172–173
- TCP/IP
 - about, 167–169
 - Internet services, 170–171
 - IP, 170
 - IP addresses, 169–170
 - port numbers, 170–171
- local command, 454
- local loop, 156
- localhost.zone file, 294–295
- locate command, 99, 122
- log analysis/monitoring tools, 441
- logcheck, 441
- logcolorise, 441
- logger command, 498, 503
- logic bombs, 394
- LOGNAME environment variable, 349
- logout command, 454
- logrotate command, 498, 503
- LogWatch, 441
- LONE-TAR utility, 362
- loop length, 158
- loops per jiffy (LPJ), 59
- /lost+found
 - directory, 111
- lowres boot option, 45
- LPI (Linux Professional Institute), 2
- LPJ (loops per jiffy), 59
- lpq command, 514
- lpr command, 99, 514
- lprm command, 514
- ls command, 98, 116–118, 119, 239, 350, 402, 495, 507
- LSB (Linux Standard Base), 15–16

lsmod command, 328,
329, 503
lsof tool, 397
LXO-101 Exam icon, 4
LXO-102 Exam icon, 4

M

M operator, 265
-m option, 478
m4 software package, 19,
260–261
macro processor, 260
macros, 260, 474–475
mail command, 258
MAIL environment
variable, 349
mail exchanger, 293
mail servers, 257–268
mail transport agent
(MTA), 257
mail user agent (MUA), 257
mail-delivery
mechanism, 259
mail-delivery test, 258
MAILER macro, 263
mailq command, 513
Main Menu button (KDE),
82–85
make command, 19,
476–478, 481
make config
command, 503
makefile
about, 473–474
names, 472–473
sample, 475–476
man command, 98, 495
managing
CD-ROMs, 49–50
CDs, 49–50
command input/output,
92–94
file systems
about, 351–352, 361

accessing DOS or
Windows file system,
368–371
backing up, 361–367
/etc/fstab file,
357–358
hierarchy, 352–355
mounting devices,
355–357
sharing with NFS,
358–361
flash drives, 49–50
flow in shell scripting,
449–451
groups, 344–345
loadable driver modules
about, 328
/etc/modprobe.conf
file, 329–330
loading/unloading
modules, 328–329
networks. *See* network
management
PC with Linux, 24–27
processes, 102–103
security, 389
user accounts
using commands,
342–343
using GUI user manager,
338–342
Mandrakelinux, 12
Mandriva Linux One, 12
manually starting/stopping
servers, 313
MASQUERADE_AS macro, 263
MASQUERADE_DOMAIN
macro, 264
masquerading, 423
MATE, 69–70, 76–77
Mbps, 154
-mcpu=cputype
option, 471
MD5 encryption, 345, 401
mdelete command, 239
mdir command, 239

media, selecting, 361–362
/media directory, 112, 354
/media/cdrom directory, 96
mediacheck boot option, 45
%MEM heading, 319
Membership, in group
definitions, 344
memory field name, 320
mem=xxxM boot option, 45
menus, Firefox, 212
MEPIS Linux, 13, 14
message digest, 393, 401
Metcalfe, Robert
(inventor), 173
mget command, 239
Microsoft Excel, 130–131
Microsoft PowerPoint,
131–132
Microsoft Word, 129
misc category, 220
misc.test newsgroup, 226
mitigation approach,
388–389
mkdir command, 98,
120–121, 239
mkfs command, 101
mknod command, 101
mkswap command, 101
mls command, 239
/mnt directory, 112, 354
Mockapetris, Paul (computer
scientist), 280
MODE parameter, 186
modinfo command,
328, 503
modprobe command, 328,
329, 330, 503
monitor, checking for
installation, 32
monitoring
system performance
about, 317
checking disk
performance/disk
usage, 321–322

top utility, 318–319
 uptime command, 319–320
 vmstat utility, 320–321
 system security, 412–413
 monolithic program, 328
 more command, 63, 99
 mount command, 101, 356, 357, 358, 368–369, 508
 mount point, 123, 356, 360, 376
 mounting
 CDs/DVDs, 25, 122–123, 355–357
 DOS floppy disks, 369–370
 DOS/Windows disk partition, 368–369
 NFS file systems, 360–361, 376–377
 NTFS partition, 370–371
 mouse, checking for installation, 32
 moving files, 495. *See also* mv command
 mput command, 239
 MTA (mail transport agent), 257
 mta parameter, 271
 MUA (mail user agent), 257
 multi option, 191
 multihomed, 191
 multimedia, defined, 127
 multimedia applications
 about, 133
 burning CDs/DVDs, 135–136
 digital camera, 133–134
 playing audio CDs, 134–135
 playing sound files, 135
 Multimedia subcategory (KickOff), 84
 multivolume archive,
 backing up and restoring, 365
 mv command, 98, 495, 506
 MX resource record type, 291, 292

N

-n command, 144
 n command, 145
 ^n command, 145
 +n command, 144
 -n option, 478
 NAME environment variable, 348
 NAME parameter, 187
 name servers, 280, 283
 named daemon, 254, 282–283, 296
 namespace, 281
 NAT (Network Address Translation), 159–161, 165–166, 421
 National Vulnerability Database (NVD) (website), 432
 Nautilus File Manager, 135
 navigating file system
 about, 114
 for changing permissions and ownerships, 118–119
 for directory listings and permissions, 116–118
 for directory navigation, 114–115
 for finding files, 121–122
 for working with directories, 120–121
 for working with files, 119–120
 ncurses software package, 19
 Nessus Security Scanner, 441
 NETBIOS, 171
 Netcat, 441
 netfilter, 421–422
 netstat command, 195, 397, 498, 515
 network address, 169, 242

Network Address Translation (NAT), 159–161, 165–166, 421
 Network Basic Input/Output System, 378
 network card, checking for installation, 32
 Network Configuration tool, 185
 Network connection icon (KDE), 85
 network devices, 327
 Network File System (NFS), 26, 373, 434
 Network Information Service (NIS), 434
 Network layer, of TCP/IP, 168
 network management
 about, 189
 configuring networks at boot time, 199–201
 TCP/IP configuration files
 about, 189
 /etc/host.conf file, 190, 191
 /etc/hosts file, 189–190
 /etc/hosts.allow file, 190, 192, 315, 435
 /etc/hosts.deny file, 190, 192–193, 315, 435
 /etc/networks file, 190
 /etc/nsswitch.conf file, 190, 193
 /etc/resolv.conf file, 190, 191
 TCP/IP networks
 about, 193
 connectivity to host, 195
 GUI tools, 198
 IP routing table, 194
 network interfaces, 193–194
 network status, 195–197
 sniffing network packets, 197–198

- Network News Transfer Protocol (NNTP), 171, 246
- network packets, sniffing, 197–198
- network security issues, 389, 390–391
- network service, 254
- networking, in CompTIA Linux+ Exam, 514–515
- NETWORKING variable, 199
- networks
 - about, 21, 26–27
 - checking status, 195–197
 - information systems, 193
 - interfaces, 193–194
 - recommended utilities, 441
 - security review, 438–439
- newaliases
 - command, 513
- newgrp command, 499, 512
- news, security and, 397–398
- news category, 220
- news servers, 268–269
- news services, 21–22
- newsfeeds file, 272–274
- newsgroups
 - about, 153, 217–218
 - adding, 276–277
 - hierarchy of, 218–219, 275–276
 - Linux-related, 221–222
 - posting news, 225–226
 - reading and searching at websites, 227–228
 - reading from ISP, 222–227
 - reading with Thunderbird, 223–225
 - setting up, 275–277
 - subscriptions to, 225
 - testing, 277
 - top-level categories of, 219–220
- NewsMonster (website), 229
- newsreader, 222–223
- Newzbot (website), 222
- next command, 481
- NFR, 441
- NFS (Network File System)
 - about, 26, 171, 373, 434
 - file sharing with
 - about, 373–374
 - exporting file systems, 374–376
 - mounting NFS file systems, 376–377
 - port numbers and, 246
 - sharing files with
 - about, 358–359
 - exporting file systems, 360
 - mounting NFS file systems, 360–361
- nfs service, 254
- nfslock service, 255
- NFSv4 implementation (website), 374
- ngrep, 441
- NI heading, 319
- nice command, 100
- NIS (Network Information Service), 434
- nl command, 99
- nlog, 441
- nmap tool, 397, 441–442
- nmbd, 378
- nmblookup, 378
- nmi_watchdog=1 boot option, 45
- nnpd, 270
- NNTP (Network News Transfer Protocol), 171, 246
- nntpsend, 270
- no_all_squash option, 375
- noapic boot option, 45
- nofirewire boot option, 45
- no_hide option, 375
- noht boot option, 45
- nomce boot option, 45
- nomount boot option, 46
- nonrepudiation, 394
- nopass boot option, 46
- nopcmcia boot option, 46
- noprobe boot option, 46
- no_root_squash option, 376
- noshell boot option, 46
- no_subtree_check option, 375
- Notifications and Jobs icon (KDE), 85
- nousb boot option, 46
- nousbstorage boot option, 46
- Novell certifications, 518
- no_wdelay option, 375
- NS resource record type, 291, 292, 295
- NTFS partition, mounting, 370–371
- ntop, 441
- NTP, port numbers and, 246
- ntpd, 513
- NVD (National Vulnerability Database) (website), 432

O

- O operator, 265
- o option, 471, 478
- O option, 471
- O1 . . . O3 options, 471
- object files, 469
- office applications, 128–132
- Office subcategory (KickOff), 84
- ONBOOT parameter, 187, 200
- 10Base2, 173
- 10Base5, 173
- 10BaseT, 173
- 127.0.0.1, reverse mapping, 295
- one-time job scheduling, 331–333

- online documentation, 22–24
 - open command, 240
 - Open Secure Shell (OpenSSH) software, 415–417
 - Open Secure Sockets Layer (Open SSL), 433
 - Open Source Initiative (website), 11
 - open source projects, 11
 - Open Windows icon (KDE), 85
 - opening terminal windows and virtual consoles, 89–90
 - operating system
 - defined, 9
 - on Linux Essentials Certification Exam, 496–498
 - updates to, 434
 - /opt directory, 112, 354
 - options statement, 288
 - Oracle certifications, 518
 - order option, 191
 - organization
 - parameter, 271
 - Os option, 471
 - OSTYPE macro, 263
 - OUTPUT chain, 424–426
 - ovmethod parameter, 271
 - ownerships
 - changing, 118–119, 350, 402
 - viewing, 402
-
- p*
- p command, 149
 - P command, 149, 265
 - p option, 478
 - pack command, 496
 - packet filter firewall, 419
 - packet filtering
 - defined, 394
 - enabling, 421–426
 - packet sniffers, recommended, 441
 - packets, 173, 394
 - PAMs (pluggable authentication modules), 401
 - Pan, 223
 - Panel toolbox (KDE), 85
 - panels
 - defined, 80
 - GNOME, 71–74
 - KDE
 - about, 82
 - icons, 85
 - Main Menu button, 82–85
 - PARC (Xerox Palo Alto Research Center), 173
 - Partial POSIX Extended Regular Expressions, 495–496
 - partition, 30
 - passwd command, 101, 397, 516
 - password, /etc/passwd file, 343
 - Password, in group definitions, 344
 - password security, 437
 - password-checking tools, recommended, 441
 - paste command, 99, 496, 507
 - patch command, 19, 99
 - PATH environment variable, 348, 349, 447–448
 - pathhost parameter, 271
 - pathname, 110–111
 - pathnews parameter, 272
 - patterns, newsgroup, 273
 - PC
 - checking hardware for installation, 31–33
 - managing with Linux, 24–27
 - reboot problem, 44
 - pci=biosirq boot option, 46
 - pci=noacpi boot option, 46
 - pcmcia service, 255
 - pedantic option, 471
 - PEERDNS parameter, 187
 - penetration test, 439
 - Pentium processor, 9, 10
 - performing risk analysis, 386–387
 - perimeter network, 394
 - period (.), 111, 119–120, 144, 494
 - peripheral, defined, 24
 - peripheral devices, 25–26
 - Perl, 23
 - permissions
 - changing, 118–119, 403
 - checking for set user ID, 405
 - directory, 116–118
 - security and file, 498–499
 - setting default, 403–405
 - viewing, 402
 - persistent device naming
 - with udev, 327–328
 - pg option, 471
 - physical console, 89
 - Physical layer, of TCP/IP, 168
 - PID heading, 319
 - ping command, 195, 441, 498, 515
 - pipe (|), 92, 105, 496
 - pkgname, 50
 - PKI (Public Key Infrastructure), 395
 - playing
 - audio CDs, 134–135
 - sound files, 135
 - pluggable authentication modules (PAMs), 401
 - plug-ins, 137
 - Point-to-Point Protocol (PPP), 327

- POP3 (Post Office Protocol version 3), 171
- popd command, 454
- port numbers, 170–171, 242, 245–247, 439
- port scanners
- defined, 394
 - recommended, 441
 - tool, 413
- portmap service, 255
- ports, 208
- post access, 274
- Post Office Protocol version 3 (POP3), 171
- posting to newsgroups, 225–226
- pound sign (#), 189, 208, 264, 271, 438. *See also* hash mark (#)
- PowerPoint (Microsoft), 131–132
- PPP (Point-to-Point Protocol), 327
- PPP over Ethernet (PPPoE), 161
- PPPoE (PPP over Ethernet), 161
- PR heading, 319
- prevention concept, in security programs, 434, 438
- primary name server, configuring, 296–298
- print command, 481
- printenv command, 100, 347
- printers
- about, 25
 - checking for installation, 32
 - setting up, 47–49
- /proc directory, 112
- /proc file system, 322–325
- process field, 311
- process file system, 323
- process ID (PID), 102–103, 309
- processes, managing, 102–103
- processing files, 104–106
- processors, 9, 10, 32
- procs field name, 320
- programming
- about, 465–467
 - software-development tools
 - about, 467
 - C++ compiler, 468–472
 - GNU C compiler, 468–472
 - GNU debugger, 478–484
 - GNU make utility, 472–478
- implications of GNU licenses, 484–487
- prompt command, 240
- protection concept, in security programs, 389, 431
- protocols
- about, 207–208
 - connectionless, 243
 - connection-oriented, 242–243
 - defined, 168
- proxy server, 395
- ps command, 63, 100, 496, 506
- pstree command, 100
- PTR resource record type, 291, 292
- public key
- cryptology, 395
 - public key encryption, 406–407
- Public Key Infrastructure (PKI), 395
- pushd command, 454
- put command, 240
- pwd command, 98, 115, 240, 454, 506
- Python, 23
-
- ## Q
-
- q command, 144, 145
- :q command, 149
 - :q! command, 149
- Q command, 145
- q option, 478
- QTParted tool, 30
- question marks (?), 95–96, 208, 494
- quit command, 240, 481
- quota command, 508
- quotation marks, 91
-
- ## R
-
- r file command, 145
- :r filename command, 149
- R operator, 265
- r option, 478
 - R option, 478
- RAM (random-access memory), 24, 32
- random-access memory (RAM), 24, 32
- RATE parameter, 187
- RC4 encryption algorithm, 182
- RCS (Revision Control System), 23
- rcs software package, 19
- reaction concept, in security programs, 389
- read access, 274
- read command, 454, 509
- readers.conf file, 274
- reading. *See* newsgroups; RSS feeds
- read_input function, 482
- readonly command, 454
- real-time clock, 513
- reboot command, 100
- reboot=b boot option, 46

rec category, 220
 Recently Used category
 (KickOff), 83
 reconfiguring BIOS, 36
 recurring job scheduling,
 333–336
 recv command, 240
 Red Hat certifications, 518
 Red Hat Linux 9, 12
 Red Hat Package Manager
 (RPM), 12, 52
 regular expressions, 494
 Remember icon, 4
 remote access, 154
 remote login, 21–22
 rename command, 240
 Rendezvous Directory
 Service, 171
 repeating previously typed
 commands, 97
 RES heading, 319
 rescue boot option, 46
 resolution=HHHxVVV
 boot option, 46
 resolver, configuring,
 285–286
 resolver library, 280, 283
 resource records (RR),
 289–293
 resources, Samba, 380
 response concept, in
 security programs, 389,
 432, 434, 438
 responsibilities, in security
 policy, 387
 Retina Network Security
 Scanner, 441
 return command, 454
 reverse mapping, zone file
 for, 295
 Revision Control System
 (RCS), 23
 rewinding tape device, 366
 Rhythbox, 135
 risk analysis, 386–387

rm command, 98, 120,
 495, 506
 RM variable, 475
 rmdir command, 98,
 240, 506
 rmmmod command,
 328, 503
 rndc utility, 288
 ro option, 375
 root, becoming
 about, 101–102, 305
 forgotten root password,
 307–308
 for GUI utilities, 307
 su - command, 306
 root access, 64
 /root directory, 111,
 112, 354
 root domain, 281
 root password, 55
 root username, 58–59
 root zone file, 293–294
 root_squash
 option, 375
 route utility, 498, 515
 RP resource record
 type, 291
 RPM (Red Hat Package
 Manager), 12, 52
 RR (resource records),
 289–293
 RSS feeds
 about, 217–218, 228–229
 reading, 229–230
 rsyslogd file, 413
 run command, 481
 runlevel command,
 310, 311
 running
 gdb, 479–481
 make, 476–478
 rw option, 375
 rwx group, 117–118
 rx command, 148

S

S heading, 319
 S operator, 265
 -s option, 478
 SAINT, 441
 Samba
 about, 26, 373
 configuring, 379–380
 installing, 378–379
 resources, 380
 setting up Windows
 server using, 377–380
 trying, 380
 samba service, 255
 SANS Institute, 432
 SARA, 441
 saving error messages in
 files, 94
 /sbin directory, 112, 354
 /sbin/hdparm
 program, 321
 /sbin/hotplug
 program, 327
 /sbin/ifconfig
 command, 193
 /sbin/route
 command, 194
 /sbin/udev program, 327
 sbpcd file, 92
 scanlogd, 441
 scheduling jobs
 about, 330–331
 one-time, 331–333
 recurring, 333–336
 sci category, 220
 screening router, 395
 screenshot, 51
 script directories, for cron
 jobs, 336
 scripting, 445
 scripts, writing, 106–108
 SCSI controller, checking
 for installation, 32
 SDSL (Symmetric DSL), 157

- searching newsgroups at websites, 227–228
- secure option, 375
- Secure Shell, 391
- Secure Shell (SSH), 171, 246
- Secure Sockets Layer (SSL), 267
- security
 - about, 383, 399
 - in CompTIA Linux+ Exam, 515–516
 - defined, 25
 - encrypting and signing files with GnuPG
 - digital signatures, 407–408
 - GPG, 408–412
 - public key encryption, 406–407
 - files and directories
 - about, 402
 - changing file ownership, 402
 - changing file permissions, 403
 - checking for set user ID permission, 405
 - setting default permission, 403–405
 - viewing ownerships and permissions, 402
 - files to be aware of, 426–427
 - framework for
 - about, 384–385
 - business requirements, 385–386
 - managing, 389
 - mitigation, 388–389
 - policy, 387–388
 - risk analysis, 386–387
 - importance of, 383–384
 - Internet services
 - about, 413
 - configuring Internet super server, 414
 - configuring TCP wrapper, 414–415
 - standalone services, 413–414
 - monitoring for system, 412–413
 - news, 397–398
 - passwords
 - about, 399–400, 437
 - pluggable authentication modules (PAMs), 401
 - shadow, 400–401
 - securing the Linux system, 389–391
 - setting up firewalls
 - about, 418–421
 - enabling packet filtering, 421–426
 - NAT, 421
 - terminology and tools, 391–397
 - testing tools, 440–442
 - updates, 397–398
 - using Secure Shell (SSH) for remote logins, 415–417
 - security audits, in security policy, 387. *See also* computer security audit
 - security level configuration tool, 422–424
 - security policy, 384, 387–388
 - sed command, 19, 99, 457–463, 507
 - Segment Violation Signal (SIGSEGV), 43
 - selecting backup strategies and media, 361–362
 - selinux=0 boot option, 46
 - semicolon (;), 380, 451, 496
 - send command, 240
 - sendmail
 - about, 22
 - alias file, 268
 - configuration file, 259–264
 - files, 266–267
 - macro, 261–264
 - mail transport agent, 259
 - service, 255, 438, 513
 - using, 257–258
 - vulnerability, 433
 - sendmail/cf file, 264–265
 - serial boot option, 46
 - server command, 250–251
 - server process, 171, 246
 - servers, automatically starting, 313–314
 - services, Internet. *See* Internet services
 - set command, 454, 509
 - set variable
 - command, 481
 - setting default permission, 403–405
 - setuid program, 395, 437
 - setup
 - Ethernet LAN, 172–175
 - local newsgroups, 275–277
 - printers, 47–49
 - Windows server with Samba, 377–380
 - SGID permission, 499
 - SHA-512, 345
 - shadow passwords, 400–401
 - shared option, 472
 - sharing files. *See* file sharing
 - Sharutils software package, 19
 - shell
 - about, 17, 60, 89
 - bash
 - about, 90
 - asterisks, 95–96
 - automatic command completion, 95
 - combining commands, 92

- command syntax, 90–92
- controlling command
 - input and output, 92–94
- question marks, 95–96
- repeating previously typed commands, 97
- commands, 61–62
- Linux commands
 - about, 62–63, 98–101
 - date, 103–104
 - managing processes, 102–103
 - processing files, 104–106
 - root, 101–102
 - time, 103–104
- opening terminal windows and virtual consoles, 89–90
- starting bash shell, 60–61
- writing scripts, 106–108
- shell, /etc/passwd file, 344
- shell command, 481
- SHELL environment variable, 349
- shell functions, 448–449
- shell scripting
 - about, 445–447
 - advanced
 - about, 463
 - awk, 459–463
 - sed, 457–463
 - basics of
 - about, 447
 - bash built-in commands, 451–455
 - controlling flow, 449–451
 - shell functions, 448–449
 - storing, 447–448
 - shell scripts, 61, 445, 509–510
 - shift command, 454
 - SHR heading, 319
 - shutdown command, 100, 503
 - shutting down, 64–65
 - Shuttleworth, Mark (developer), 74
 - SIG resource record type, 291
 - signal 11 error, 43, 115
 - SIGSEGV (Segment Violation Signal), 43
 - simple file, 107
 - Simple Mail Transfer Protocol (SMTP), 171, 246
 - Simple Network Management Protocol (SNMP), 171, 246, 433
 - single dot (.), 115
 - single-volume archive, backing up and restoring, 363–365
 - size command, 240
 - skipddc boot option, 46
 - Slackware Linux, 13
 - slash (/), 116, 143, 147, 352–353
 - Slashdot (website), 230
 - smbadduser, 378
 - smbcacls, 378
 - smbclient, 378
 - smbcontrol, 378
 - smbd, 378
 - smbmount, 378
 - smbpasswd, 378
 - smbprint, 378
 - smbstatus, 378
 - smbtar, 378
 - smbumount, 378
 - SMTP (Simple Mail Transfer Protocol), 171, 246
 - sniffer, defined, 395
 - sniffing network packets, 197–198
 - sniffit, 441
 - SNMP (Simple Network Management Protocol), 171, 246, 433
 - snmpd service, 255
 - Snort, 441
 - SOA resource record type, 291, 295
 - soc category, 220
 - sockets
 - client/server model and, 243–244
 - TCP/IP and, 242–245
 - software
 - defined, 9
 - GNU, 16–19
 - installing
 - about, 50
 - in Debian and Ubuntu, 50–52
 - in Fedora, 52–54
 - in SUSE, 54
 - in Xandros, 55
 - software development, 22
 - software-development tools
 - about, 467
 - C++ compiler, 468–472
 - GNU C compiler, 468–472
 - GNU debugger, 478–484
 - GNU make utility, 472–478
 - implications of GNU licenses, 484–487
 - s/old/new/
 - command, 145
 - sort command, 99, 105
 - sorting text files, 105
 - sound card
 - about, 26
 - checking for
 - installation, 32
 - sound files, playing, 135
 - source code, 11
 - spamassassin service, 255
 - split command, 99, 106
 - splitting files into smaller files, 106
 - spoofing, 418
 - spyware, 395
 - square brackets ([]), 95–96
 - /srv directory, 112, 354
 - SRV resource record type, 291

- ssh, 391
- SSH (Secure Shell), 171, 246
- ssh service, 255
- sshd, 22
- SSL (Secure Sockets Layer), 267
- stable releases, 15
- standalone servers
 - about, 250
 - starting and stopping manually, 250–251
 - starting automatically, 251–255
 - turning off, 413–414
- standalone services, security of, 438–439
- standard error, 92–94
- standard input, 92–94
- standard output, 92–94
- standards, wireless
 - Ethernet, 179–180
- starting
 - bash shell, 60–61
 - caching name server, 295–296
 - INN server, 269–275
 - Linux, 57–60
- STARTTLS extension, 267
- startup, InterNetNews, 274–275
- startup scripts, 312–313
- stateful inspection firewall, 419–420
- statements, 466
- statistical attacks, 182
- status bar, Firefox, 211
- status command, 240
- stderr, 92–94, 496
- stdin, 92–94, 496
- stdout, 92–94
- step command, 481
- sticky keys, 511
- storing, in shell scripting, 447–448
- stream cipher, 182
- stream editor, 458
- stream-based macro, 260
- /string command, 149
- ?string command, 149
- Strobe, 441
- su command, 101, 102, 306, 397, 499, 516
- subscriptions, to
 - newsgroups, 225
- substituting characters
 - from files, 105–106
- subtree_check
 - option, 375
- Subversion, Concurrent Versions System (CVS), 23, 433
- subversion,
 - vulnerability, 433
- sudo tool, 397, 499, 516
- suid permission, 405
- superuser, 101–102, 516
- SUSE
 - about, 13
 - BIND, 282
 - certifications from, 518
 - chkconfig command, 251–252, 314
 - configuring
 - networks, 200
 - Samba, 379
 - wireless network in, 187
 - directory option, 288
 - distributions, 38
 - /etc/fstab file, 357–358
 - init process, 310
 - installing
 - INN server, 268
 - software in, 54
 - software-development tools, 467
 - reading RSS feeds, 230
 - recovering from forgotten root password, 308
 - security level configuration tool, 422, 423
 - starting
 - innd, 275
 - NFS server, 359, 376
 - Samba, 380
 - standalone servers in, 251
 - stopping standalone servers in, 251
 - turning off standalone servers, 414
 - updates, 398
 - swap field name, 321
 - swapoff command, 101
 - swapon command, 101
 - swapping, 321
 - Swatch, 441
 - symbolic links, 117, 252, 516
 - Symmetric DSL (SDSL), 157
 - symmetric key
 - encryption, 395
 - Synaptic Package Manager, 51
 - sync command, 101, 375
 - /sys directory, 112
 - sysfs program, 327
 - syslog service, 255
 - syslogd file, 413
 - system administration
 - about, 25
 - becoming root
 - about, 305
 - forgotten root password, 307–308
 - for GUI utilities, 307
 - su command, 306
 - GUI tools, 303–305
 - Linux boots
 - automatically starting servers, 313–314
 - /etc/inittab file, 310–311
 - init command, 311–312
 - init process, 308–310
 - manually starting/stopping servers, 313
 - startup scripts, 312–313
 - Linux configuration files, 314–317

Linux devices
 about, 325–326
 device files, 326–327
 persistent device
 naming with `udev`,
 327–328
 managing loadable
 driver modules
 about, 328
`/etc/modprobe.conf`
 file, 329–330
 loading/unloading
 modules, 328–329
 monitoring system
 performance,
 318–321
 scheduling jobs
 about, 330–331
 one-time, 331–333
 recurring, 333–336
 tasks, 301–302
 viewing system
 information with /
`proc` file system,
 322–325
 system architecture, in
 CompTIA Linux+ Exam,
 502–503
 system field name, 321
 system information,
 viewing with `/proc` file
 system, 322–325
 system performance,
 monitoring
 about, 317
 checking disk
 performance/disk
 usage, 321–322
`top` utility, 318–319
`uptime` command,
 319–320
`vmstat` utility, 320–321
 System subcategory
 (KickOff), 84

T

T operator, 265
 -t option, 478
 tabbed browsing, 210
`tac` command, 99
`tail` command, 99
 talk category, 220
 tapes, backing up on, 366
`tar` command, 19, 100,
 363–367, 496
 tasks
 by category in YaST
 Control Center, 305
 system administration,
 301–302
 TCP wrapper
 access control files, 391
 security, configuring,
 414–415
`tcpdstats`, 441
`tcpdump` command,
 197, 441
 TCP/IP (Transmission
 Control Protocol/
 Internet Protocol)
 about, 21, 167–169
 configuration files
 about, 189
`/etc/host.conf` file,
 190, 191
`/etc/hosts` file,
 189–190
`/etc/hosts.allow`
 file, 190, 192
`/etc/hosts.deny` file,
 190, 192–193
`/etc/networks` file,
 190
`/etc/nsswitch.conf`
 file, 190, 193
`/etc/resolv.conf`
 file, 190, 191
 configuring networking,
 175–177
 four-layer network model,
 168–169
 Internet services,
 170–171
 IP, 170
 IP addresses, 169–170
 networks
 about, 193
 checking connectivity to
 host, 195
 checking IP routing
 table, 194
 checking network
 interfaces, 193–194
 checking network status,
 195–197
 sniffing network packets,
 197–198
 using GUI tools, 198
 port numbers, 170–171
 sockets and, 242–245
 Technical Stuff icon, 4
`telinit` command, 312
`telnet`, 515
 TELNET, 171, 246
 Temporal Key Integrity
 Protocol (TKIP), 181
 TERM environment variable,
 348, 349
 terminal, 89
 terminal windows, opening,
 89–90
`test` command,
 449–450, 509
 testing
 caching name server,
 295–296
 newsgroups, 277
 vulnerabilities, 440
 testing releases, 15
`testparm` command,
 378, 379

texinfo software
 package, 19
 /text/ command, 144
 ?text? command, 144
 text editors
 about, 139, 467
 with ed, 141–145
 GUI, 139–141
 with vi, 141, 145–149
 text files
 counting words/lines in,
 104–105
 sorting, 105
 text input mode, 142, 146
 text mode installation, 38
 text terminal, 16
 TFTP (Trivial File Transfer
 Protocol), 171, 246
 thick Ethernet, 173
 thicknet, thickwire, 173
 thinwire, 173
 32-bit cyclic redundancy
 code (CRC-32), 182
 threats
 defined, 395
 typical, 386
 Thunderbird, 222, 223–225
 tilde (~) character, 115, 146
 time, working with, 103–104
 time command, 19,
 103–104
 TIME+ heading, 319
 Time icon (KDE), 85
 Time To Live (TTL), 289
 times command, 454
 Tip icon, 4
 TKIP (Temporal Key
 Integrity Protocol), 181
 /tmp directory, 112, 354
 Tool Command Language
 and graphical toolkit
 (Tcl/Tl), 23
 toolbars, Firefox, 211
 tools, GUI, 198, 303–305
 Tools menu (Firefox), 212
 top command, 100,
 496, 506

Top Cyber Security Risks
 index (website), 432
 top panel (GNOME), 72
 top utility, 318–319
 top-level directories,
 111–112
 Torvalds, Linus (Linux
 developer), 1, 10
 touch command, 98
 tr command, 99,
 105–106, 507
 traceroute, 515
 Transmission Control
 Protocol/Internet
 Protocol. *See* TCP/IP
 (Transmission Control
 Protocol/Internet
 Protocol)
 Transport layer, of
 TCP/IP, 168
 trap command, 454
 Tripwire, 390, 412, 441
 Trivial File Transfer
 Protocol (TFTP),
 171, 246
 Trojan horse, 396
 troubleshooting
 about, 37
 CD-ROMs, 49–50
 DVDs, 49–50
 flash drives, 49–50
 installation
 about, 40
 Knoppix boot
 commands, 40–43
 Linux kernel boot
 options, 44–47
 PC reboot, 44
 signal 11 error, 43
 printer setup, 47–49
 text mode installation, 38
 workstation, 36
 X, 38–40
 Ts, Jay (author)
 Using Samba,
 3rd Edition, 380
 TTL (Time To Live), 289

tty command, 101
 turning off standalone
 servers, 413–414
 24-bit IV, 182
 TXT resource record
 type, 291
 type command, 455
 TYPE parameter, 187

U

u command, 145, 149
 U command, 149
 Ubuntu
 BIND, 282
 configuring networks, 199
 distributions, 38
 init process, 310
 installing
 INN server, 268
 Samba, 379
 software in, 50–52
 starting
 innd, 275
 Samba, 380
 standalone servers
 in, 251
 stopping standalone
 servers in, 251
 turning off standalone
 servers, 413
 update-rc.d command,
 252–253, 314
 updates, 398
 Ubuntu Linux, 13
 udev, persistent device
 naming with, 327–328
 UDP (User Datagram
 Protocol), 243
 UID, /etc/passwd
 file, 343
 ulimit command, 397,
 455, 516
 -UMACRO option, 472
 umask command,
 403–405, 455

- umount command, 101, 356–357
 - unalias command, 98, 455
 - uname command, 62, 100
 - unauthorized access, 386
 - uncompress command, 100
 - Uniform Resource Locators (URLs), 206–208
 - uniq command, 99
 - United States Computer Emergency Readiness Team (website), 397
 - Unity, 69–70, 74–75
 - Unix commands, in
 - CompTIA Linux+ Exam, 505–507
 - Unix-to-Unix Copy Protocol (UUCP), 218
 - unloading modules, 328–329
 - unmounting, 122–123, 369–370
 - unset command, 455, 509
 - unshielded twisted-pair cable (UTP), 173
 - unstable releases, 15
 - update-rc.d command, 252–253, 314
 - updates, security, 397–398
 - updating
 - configuration lists, 276
 - operating systems, 434
 - upstream data, 161
 - uptime command, 319–320, 516
 - URLs (Uniform Resource Locators), 206–208
 - USB interface, 26
 - US-CERT National Cyber Alert System mailing list, 398
 - Usenet, 218
 - Usenet Replayer (website), 227
 - user command, 240
 - User Datagram Protocol (UDP), 243
 - user file-creation mask, 403
 - USER heading, 319
 - user interfaces and
 - desktops, in CompTIA Linux+ Exam, 510–511
 - useradd command, 499, 512
 - USERCTL parameter, 187
 - userdel command, 499
 - usermod tool, 397, 516
 - username, /etc/passwd file, 343
 - users. *See also* groups
 - about, 337
 - adding user accounts
 - about, 337–338
 - using commands, 342–343
 - using GUI user manager, 338–342
 - administration values, 345–347
 - changing ownership of files, 350
 - environment, 347–349
 - /etc/passwd file, 343–344
 - Using Samba*, 3rd Edition (Ts, Eckstein & Collier-Brown), 380
 - /usr directory, 112, 113, 354
 - /usr/bin/scp, 416
 - /usr/bin/slogin, 416
 - /usr/bin/ssh, 416
 - /usr/bin/ssh-keygen, 416
 - /usr/sbin/sshd, 416
 - utilities, commercial
 - backup, 362–363. *See also specific utilities*
 - Utilities subcategory (KickOff), 84
 - utility programs, 284–285
 - UTP (unshielded twisted-pair cable), 173
 - UUCP (Unix-to-Unix Copy Protocol), 218
-
- ## V
-
- v operator, 265
 - v option, 472, 478
 - /var directory, 112, 113–114, 354
 - variables
 - about, 474–475
 - defined, 466
 - /var/log/dmesg file, 317
 - /var/log file, 412, 436
 - /var/log/apache2 file, 317
 - /var/log/boot.msg file, 317
 - /var/log/cron file, 317
 - /var/log/httpd file, 317
 - /var/log/lastlog file, 436
 - /var/log/messages file, 317, 436, 503
 - /var/log/wtmp file, 436
 - vendor-neutral
 - certifications, 517
 - vendor-specific
 - certifications, 518
 - version-control
 - system, 467
 - VERSIONID macro, 263
 - versions, 14–15, 228
 - Vetescan, 441
 - vi text editor, 141, 145–149, 467
 - video card, checking for installation, 32
 - View menu (Firefox), 212
 - viewing
 - online help in vi, 147
 - ownerships and permissions, 402
 - system information with /proc file system, 322–325
 - VIRT heading, 319
 - virtual consoles, opening, 89–90

virus, 396
 visual command mode, 146
 vmstat utility, 320–321
 vnc boot option, 46
 Volume icon (KDE), 85
 vsftpd service, 22, 255
 vulnerabilities
 common, 432–434
 defined, 396
 testing, 440
 typical, 387
 vulnerability scanners,
 439, 441

W

w command, 149, 499
 w file command, 145
 W file command, 145
 :w filename command,
 149
 -w option, 472, 478
 -W option, 478
 -W1 option, 472
 wait command, 455
 WAP (wireless access
 point), 184
 war-dialing, 396
 war-driving, 396
 Warning! icon, 4
 watch command, 481
 wc command, 100, 104–105,
 496, 507
 wdelay option, 375
 Web, 153
 web browsing
 about, 205–206
 links, 206–208
 in Linux, 209–216
 URLs, 206–208
 web servers, 209
 web servers, 209
 web surfing, in Firefox,
 215–216

websites. *See also specific
 websites*
 distance limits, 154
 downstream transfer
 speed, 163
 reading newsgroups at,
 227–228
 searching newsgroups at,
 227–228
 signal 11 error, 43
 WEP (Wired Equivalent
 Privacy), 181–182
 whatis command, 98, 495
 where command, 481
 whereis command, 99
 which command, 99
 Whisker, 441
 white box, 440
 who command, 499, 516
 Wi-Fi (Wireless
 Fidelity), 179
 Wi-Fi Alliance
 (website), 180
 Wi-Fi Protected Access
 (WPA), 181
 Wi-Fi Protected Access 2
 (WPA2), 181
 wildcards, 95–96, 494
 wildmat pattern, 273
 WIMP (windows, icons,
 mouse, and pointer), 60
 winbind service, 255
 winbindd, 378
 windows, icons, mouse, and
 pointer (WIMP), 60
 Windows file system,
 accessing, 368–371
 Windows partition,
 reducing size of, 33–34
 Windows server, setting up
 using Samba, 377–380
 Wired Equivalent Privacy
 (WEP), 181–182
 wireless access point
 (WAP), 184

wireless Ethernet networks
 about, 179–180
 ad hoc modes, 180–181
 infrastructure, 180–181
 Wired Equivalent Privacy
 (WEP), 181–182
 wireless local area network
 (WLAN), 179
 wireless networks
 configuring
 about, 185–188
 wireless access
 point, 184
 setting up wireless
 hardware, 183–184
 wireless Ethernet
 networks
 about, 179–180
 ad hoc modes, 180–181
 infrastructure, 180–181
 Wired Equivalent Privacy
 (WEP), 181–182
 Wireshark (website), 198
 WLAN (wireless local area
 network), 179
 Word (Microsoft), 129
 working configuration
 file, 39
 workstation,
 troubleshooting, 36
 World Wide Web, 21–22
 worm, 396
 WPA (Wi-Fi Protected
 Access), 181
 :wq command, 149
 Writer (LibreOffice.org), 129
 writing shell scripts,
 106–108

X

X, troubleshooting, 38–40
 x command, 148, 481
 X Window System, 11,
 19–20

Xandros
 about, 12
 BIND, 282
 configuring networks, 199
 distributions, 38
 init process, 310
 installing
 INN server, 268
 software in, 55
 software-development
 tools, 467
 starting
 innd, 275
 NFS server, 359
 Samba, 380
 turning off standalone
 servers, 413
 update-rc.d command,
 252–253, 314
 updates, 398

Xandros Desktop OS, 13
Xandros File Manager, 135
xargs command, 496
xdpyinfo utility, 510
Xerox Palo Alto Research
 Center (PARC), 173
XFree86 Project, 20
xfs service, 255
xinetd server, 248–250,
 255, 413, 415, 438
XMMS, 135
xwininfo utility, 510

Y

YaST Control Center, 187,
 259, 282, 303–305
Yellowdog Update,
 Modified (yum), 505

ypbind service, 255
yy command, 149

Z

zcat command, 100
zless command, 100
zmore command, 100
zone statement, 288, 293–294
zone transfer, 283

About the Author

Emmett Dulaney is the author of several books on operating systems and certifications, and an associate professor at Anderson University. Other books he has written include *CompTIA A+ Complete Study Guide* (Sybex) and the *CompTIA Security + Study Guide* (Sybex).

Emmett is a columnist for *Certification Magazine* and *Campus Technology*. He is also contributor to a number of other magazines.

Dedication

For Karen, Kristin, Evan, and Spencer.

Author's Acknowledgments

I would like to thank Naba Barkakati, who wrote the first two editions and did a fantastic job of condensing a wealth of information into a small tome.

I would also like to thank Elizabeth Zinkann for being one of the best technical editors in the business, and Pat O'Brien for keeping everything on track and on time.

Publisher's Acknowledgments

Senior Acquisitions Editor: Kyle Looper

Project Editor: Pat O'Brien

Copy Editor: Barry Childs-Helton

Technical Editor: Elizabeth Zinkann

Editorial Assistant: Annie Sullivan

Sr. Editorial Assistant: Cherie Case

Project Coordinator: Patrick Redmond

Cover Image: ©iStock.com/Coldimages

Apple & Mac

iPad For Dummies,
6th Edition

978-1-118-72306-7

iPhone For Dummies,
7th Edition

978-1-118-69083-3

Macs All-in-One
For Dummies, 4th Edition

978-1-118-82210-4

OS X Mavericks
For Dummies

978-1-118-69188-5

Blogging & Social Media

Facebook For Dummies,
5th Edition

978-1-118-63312-0

Social Media Engagement
For Dummies

978-1-118-53019-1

WordPress For Dummies,
6th Edition

978-1-118-79161-5

Business

Stock Investing
For Dummies, 4th Edition

978-1-118-37678-2

Investing For Dummies,
6th Edition

978-0-470-90545-6

Personal Finance
For Dummies, 7th Edition

978-1-118-11785-9

QuickBooks 2014
For Dummies

978-1-118-72005-9

Small Business Marketing
Kit For Dummies,
3rd Edition

978-1-118-31183-7

Careers

Job Interviews
For Dummies, 4th Edition

978-1-118-11290-8

Job Searching with Social
Media For Dummies,
2nd Edition

978-1-118-67856-5

Personal Branding
For Dummies

978-1-118-11792-7

Resumes For Dummies,
6th Edition

978-0-470-87361-8

Starting an Etsy Business
For Dummies, 2nd Edition

978-1-118-59024-9

Diet & Nutrition

Belly Fat Diet For Dummies

978-1-118-34585-6

Mediterranean Diet
For Dummies

978-1-118-71525-3

Nutrition For Dummies,
5th Edition

978-0-470-93231-5

Digital Photography

Digital SLR Photography
All-in-One For Dummies,
2nd Edition

978-1-118-59082-9

Digital SLR Video &
Filmmaking For Dummies

978-1-118-36598-4

Photoshop Elements 12
For Dummies

978-1-118-72714-0

Gardening

Herb Gardening
For Dummies, 2nd Edition

978-0-470-61778-6

Gardening with Free-Range
Chickens For Dummies

978-1-118-54754-0

Health

Boosting Your Immunity
For Dummies

978-1-118-40200-9

Diabetes For Dummies,
4th Edition

978-1-118-29447-5

Living Paleo For Dummies

978-1-118-29405-5

Big Data

Big Data For Dummies

978-1-118-50422-2

Data Visualization
For Dummies

978-1-118-50289-1

Hadoop For Dummies

978-1-118-60755-8

Language & Foreign Language

500 Spanish Verbs
For Dummies

978-1-118-02382-2

English Grammar
For Dummies, 2nd Edition

978-0-470-54664-2

French All-in-One
For Dummies

978-1-118-22815-9

German Essentials
For Dummies

978-1-118-18422-6

Italian For Dummies,
2nd Edition

978-1-118-00465-4

 Available in print and e-book formats.

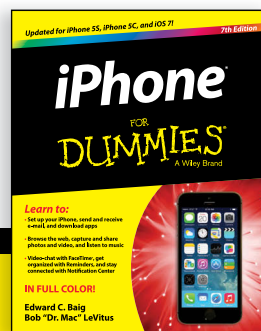
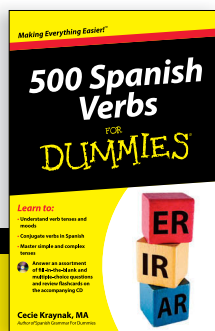
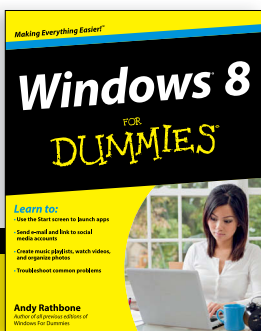
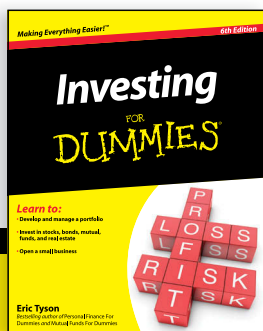

Available wherever books are sold. For more information or to order direct visit www.dummies.com

Math & Science

Algebra I For Dummies,
2nd Edition
978-0-470-55964-2

Anatomy and Physiology
For Dummies, 2nd Edition
978-0-470-92326-9

Astronomy For Dummies,
3rd Edition
978-1-118-37697-3

Biology For Dummies,
2nd Edition
978-0-470-59875-7

Chemistry For Dummies,
2nd Edition
978-1-118-00730-3

1001 Algebra II Practice
Problems For Dummies
978-1-118-44662-1

Microsoft Office

Excel 2013 For Dummies
978-1-118-51012-4

Office 2013 All-in-One
For Dummies
978-1-118-51636-2

PowerPoint 2013
For Dummies
978-1-118-50253-2

Word 2013 For Dummies
978-1-118-49123-2

Music

Blues Harmonica
For Dummies
978-1-118-25269-7

Guitar For Dummies,
3rd Edition
978-1-118-11554-1

iPod & iTunes
For Dummies, 10th Edition
978-1-118-50864-0

Programming

Beginning Programming
with C For Dummies
978-1-118-73763-7

Excel VBA Programming
For Dummies, 3rd Edition
978-1-118-49037-2

Java For Dummies,
6th Edition
978-1-118-40780-6

Religion & Inspiration

The Bible For Dummies
978-0-7645-5296-0

Buddhism For Dummies,
2nd Edition
978-1-118-02379-2

Catholicism For Dummies,
2nd Edition
978-1-118-07778-8

Self-Help & Relationships

Beating Sugar Addiction
For Dummies
978-1-118-54645-1

Meditation For Dummies,
3rd Edition
978-1-118-29144-3

Seniors

Laptops For Seniors
For Dummies, 3rd Edition
978-1-118-71105-7

Computers For Seniors
For Dummies, 3rd Edition
978-1-118-11553-4

iPad For Seniors
For Dummies, 6th Edition
978-1-118-72826-0

Social Security
For Dummies
978-1-118-20573-0

Smartphones & Tablets

Android Phones
For Dummies, 2nd Edition
978-1-118-72030-1

Nexus Tablets
For Dummies
978-1-118-77243-0

Samsung Galaxy S 4
For Dummies
978-1-118-64222-1

Samsung Galaxy Tabs
For Dummies
978-1-118-77294-2

Test Prep

ACT For Dummies,
5th Edition
978-1-118-01259-8

ASVAB For Dummies,
3rd Edition
978-0-470-63760-9

GRE For Dummies,
7th Edition
978-0-470-88921-3

Officer Candidate Tests
For Dummies
978-0-470-59876-4

Physician's Assistant Exam
For Dummies
978-1-118-11556-5

Series 7 Exam For Dummies
978-0-470-09932-2

Windows 8

Windows 8.1 All-in-One
For Dummies
978-1-118-82087-2

Windows 8.1 For Dummies
978-1-118-82121-3

Windows 8.1 For Dummies,
Book + DVD Bundle
978-1-118-82107-7



Available in print and e-book formats.

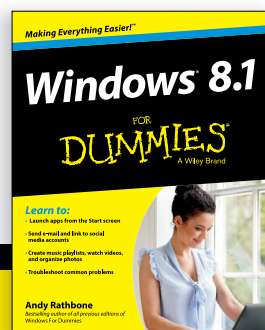
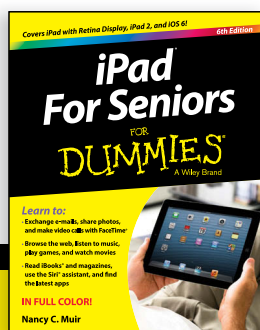
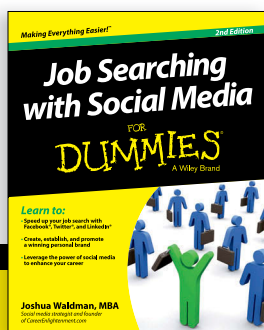
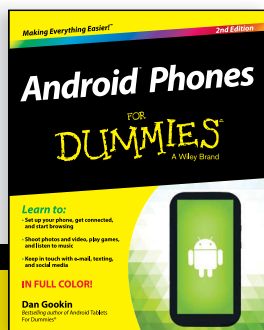

Available wherever books are sold. For more information or to order direct visit www.dummies.com

Take Dummies with you everywhere you go!

Whether you are excited about e-books, want more from the web, must have your mobile apps, or are swept up in social media, Dummies makes everything easier.



Visit Us



bit.ly/JE00

Like Us



on.fb.me/1f1ThNu

Follow Us



bit.ly/ZDytkR

Watch Us



bit.ly/gbOQHn

Join Us



linkd.in/1gurkMm

Pin Us



bit.ly/16caOLd

Circle Us



bit.ly/1aQTuDQ

Shop Us



bit.ly/4dEp9

Leverage the Power

For Dummies is the global leader in the reference category and one of the most trusted and highly regarded brands in the world. No longer just focused on books, customers now have access to the For Dummies content they need in the format they want. Let us help you develop a solution that will fit your brand and help you connect with your customers.

Advertising & Sponsorships

Connect with an engaged audience on a powerful multimedia site, and position your message alongside expert how-to content.

Targeted ads • Video • Email marketing • Microsites • Sweepstakes sponsorship

The screenshot displays the For Dummies website interface. At the top, the logo 'FOR DUMMIES A Wiley Brand' is accompanied by the tagline 'Making Everything Easier'. A search bar and social media icons (Facebook, Google+, Twitter, YouTube, RSS) are visible. A yellow banner promotes a sweepstakes: 'Pin it to Win it DUMMIES' with a chance to win '\$10,000'. Below this, a navigation menu lists categories such as Business & Careers, Computers & Software, Consumer Electronics, Crafts & Hobbies, Education & Languages, Food & Drink, Health & Fitness, Home & Garden, Internet & Social Media, Music & Creative Arts, Personal Finance, Pets, Photography & Video, Relationships & Family, Religion & Spirituality, Sports & Outdoors, and Games. The main content area features a large banner for the 'NEW For Dummies eLearning Center' with the slogan 'anything is easy!' and icons for various topics like Excel, PowerPoint, Access, HTML, Photography, and Word. Below the banner, there's a section for 'Job Searching' with featured articles and a 'Featured Product' section for 'Answering Tough Interview Questions'. On the right, there are links to 'Business Plan' and 'Application Management'.

**21 Million
Monthly Page
Views &
13 Million Unique
Visitors**

of For Dummies

Custom Publishing

Reach a global audience in any language by creating a solution that will differentiate you from competitors, amplify your message, and encourage customers to make a buying decision.

Apps • Books • eBooks • Video • Audio • Webinars

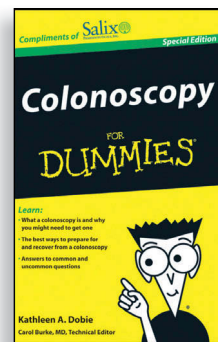
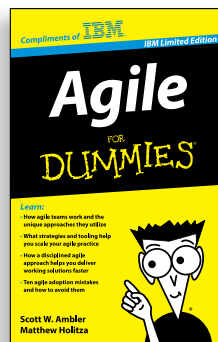
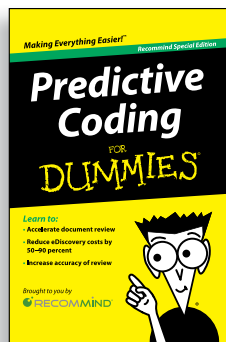
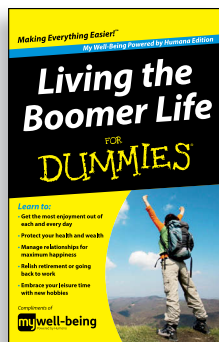

Brand Licensing & Content

Leverage the strength of the world's most popular reference brand to reach new audiences and channels of distribution.

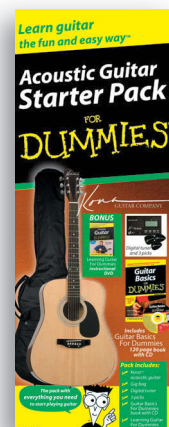
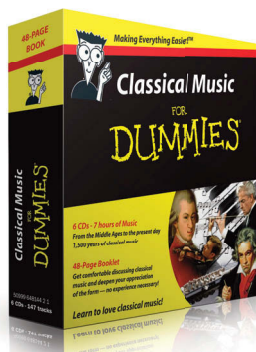

For more information, visit www.Dummies.com/biz

Dummies products make life easier!

- DIY
- Consumer Electronics
- Crafts
- Software
- Cookware
- Hobbies
- Videos
- Music
- Games
- and More!

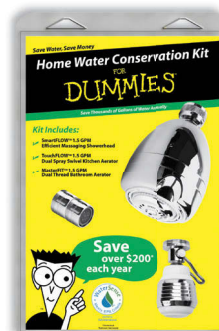
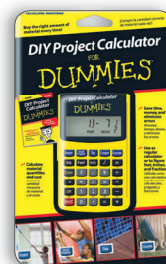
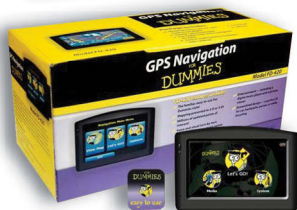
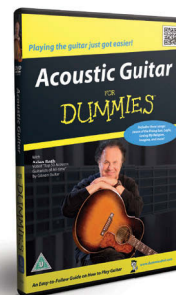
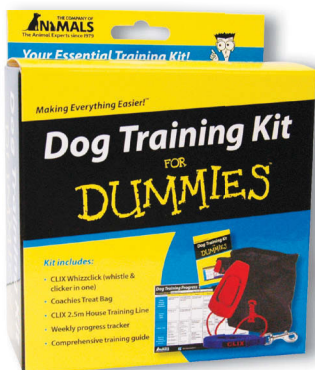

For more information, go to **Dummies.com** and search the store by category.

At home, at work, or on the go, Dummies is here to help you go digital!



From eLearning to e-books, test prep to test banks,
language learning to video training, mobile apps, and more,
Dummies makes learning easier.